

Corner and Bay Fireplace Conversion Addendum

Generation 7220

Model # GEN-7220

Direct Vent Gas Fireplace

English and French installation manuals are available through your local dealer or website. Visit our website www.kozyheat.com.

Les manuels d'installation en français et en anglais sont disponibles chez votre détaillant local. Visitez www.kozyheat.com.

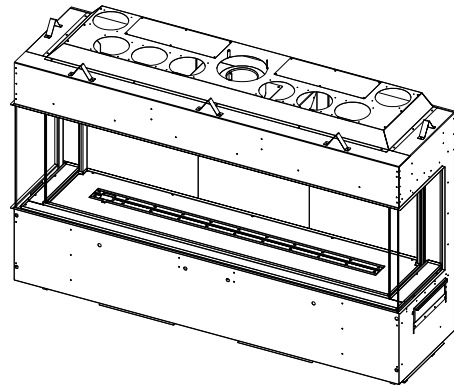

⚠ WARNING:

FIRE OR EXPLOSION HAZARD

Failure to follow safety warnings exactly could result in serious injury, death, or property damage.

- **Do not** store or use gasoline or other flammable vapors and liquids in the vicinity of this or any other appliance.
- Installation and service must be performed by a qualified installer, service agency or the gas supplier.
- **CAUTION:** Before fireplace start-up, check all connections for leaks with soapy water, whether field or factory made.

WHAT TO DO IF YOU SMELL GAS

- **Do not** try to light any appliance.
- **Do not** touch any electrical switch; **Do not** use any phone in your building.
- Leave the building immediately.
- Immediately call your gas supplier from a neighbor's phone. Follow the gas supplier's Instructions.
- If you cannot reach your gas supplier, call the fire department.

This appliance may be installed in an aftermarket, permanently located, manufactured home (USA only) or mobile home, where not prohibited by local codes.

This appliance is only for use with the type of gas indicated on the rating plate. A conversion kit is supplied with the appliance.

⚠ DANGER



HOT GLASS WILL CAUSE BURNS
DO NOT TOUCH GLASS UNTIL COOLED
NEVER ALLOW CHILDREN TO TOUCH GLASS

A barrier designed to reduce the risk of burns from the hot viewing glass is provided with this appliance and shall be installed for the protection of children and other at-risk individuals.

INSTALLER: Leave this manual with the appliance.

CONSUMER: Retain this manual for future reference.

Table of Contents

1.0 Appliance Information and Preparation	3	4.0 Fireplace Setup	71
1.1 Converting the Single-Sided to a Corner or Three-Sided (Bay) Fireplace	3	4.1 Safety Glass Barriers	71
1.2 Safety Glass Barriers	6	4.2 Perimeter Media Tray	75
1.3 Typical Corner Fireplace Installations	7	4.3 Firebox Glass.....	76
1.4 Typical 3-Sided (Bay) Fireplace Installations	8	4.4 Black Glass Panel Installation.....	80
1.5 Clearances to Combustibles.....	9	4.5 Control Board Removal and Installation	82
1.6 Mounting a Television Above a Fireplace and Television Recess Construction.....	10		
1.7 Elevated Platform Installation.....	12		
1.8 How to Hide the Air Intake Opening.....	14		
1.9 Clearance to Sprinkler	15		
1.10 Wall Thimble Framing Instructions - Minimum Horizontal	15		
2.0 Corner Installation	16		
2.1 Framing.....	16		
2.2 Recessed Fireplace Framing	17		
2.3 Facing Requirements	19		
2.4 Requirements to Cool the Fireplace Chamber and Safety Glass Barriers.....	20		
2.5 Hearth, Mantel, Front Chamber, and Side Chamber Projection for KZK Options	29		
2.6 Hearth, Mantel, Front Chamber, and Side Chamber Projection for Vented Cavity Options	34		
2.7 Clearance to a Sidewall.....	39		
3.0 Three-Sided (Bay) Installation	40		
3.1 Framing.....	40		
3.2 Recessed Fireplace Framing.....	41		
3.3 Facing Requirements	43		
3.4 Requirements to Cool the Fireplace Chamber and Safety Glass Barriers.....	44		
3.5 Hearth, Mantel, Front Chamber, and Side Chamber Projection for KZK Options	60		
3.6 Hearth, Mantel, Front Chamber, and Side Chamber Projection for Vented Cavity Options	65		
3.7 Clearance to a Sidewall.....	70		

1.0 Appliance Information and Preparation

NOTE: This addendum manual does not include all the information you need for your fireplace installation. You will need to refer to the single-side manual that shipped with the fireplace for information that pertains to all installation scenarios. This addendum only includes information specific to a corner or 3-sided (Bay) installation.

1.1 Converting the Single-Sided to a Corner or Three-Sided (Bay) Fireplace

This section outlines the procedure to convert the appliance from the standard single-sided fireplace to a corner or three-sided (Bay) fireplace. The fireplace is shipped with block-off plates on both sides. Purchase (1) Corner Conversion Kit (Part# GENL-CCK) for a left or right corner installation. Purchase (2) Corner Conversion Kits (Part# GENL-CCK) for a Bay Installation.

Figure 1.1 shows the full conversion process for both sides of the fireplace. If you want a corner fireplace then only remove the block off plate for the side of the fireplace you want visible and perform the conversion to that side. For a three-sided (Bay) fireplace then follow all instructions to complete the conversion on both sides.

Note: You may find it easier to install the black glass panels (interior rear panels and exterior perimeter panels) after this conversion is completed but before you install the exterior safety glass barrier.

1. Remove and discard the nailing flanges and side block off plates for one or both sides depending on your installation choice. See Figure 1.1. Save these screws for Step 2.
2. Install the top finishing edge bracket. Please note that the kit comes with a left and right top finishing edge bracket. Use the bracket for the side you are converting and discard the trim piece that is not used. The top finishing edge bracket fits in the fireplace between the outer shell and the top glass retention bracket. This top finishing edge bracket is installed by securing it to the inside of the fireplace via (2) sheet metal screws. See Figure 1.2.
3. Install the bottom finishing edge bracket. This bottom bracket is pressure fit so push it in between the outer shell and the retention bracket.

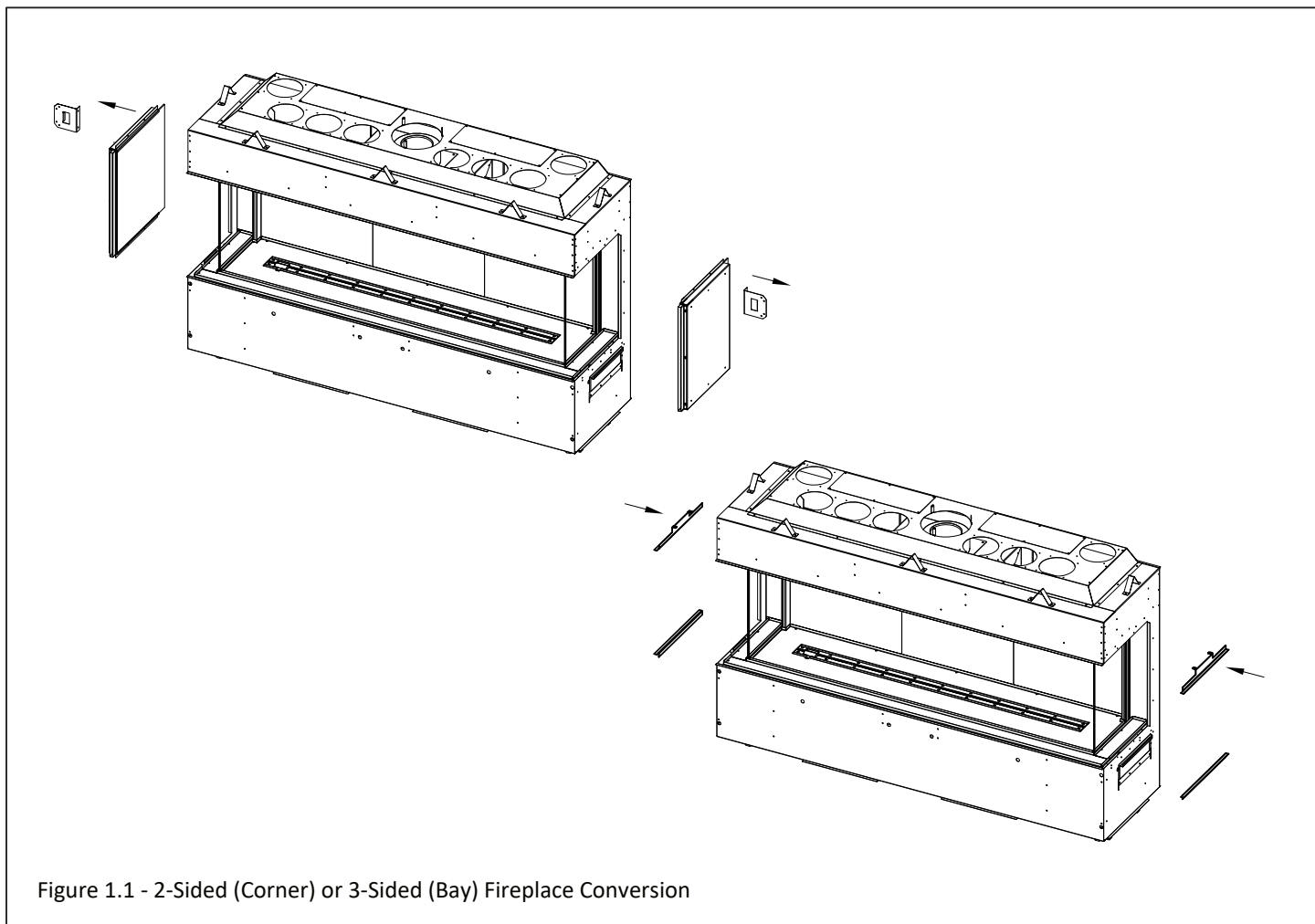

Figure 1.1 - 2-Sided (Corner) or 3-Sided (Bay) Fireplace Conversion

1.1 Converting the Single-Sided to a Corner or Three-Sided (Bay) Fireplace Conversion (continued)

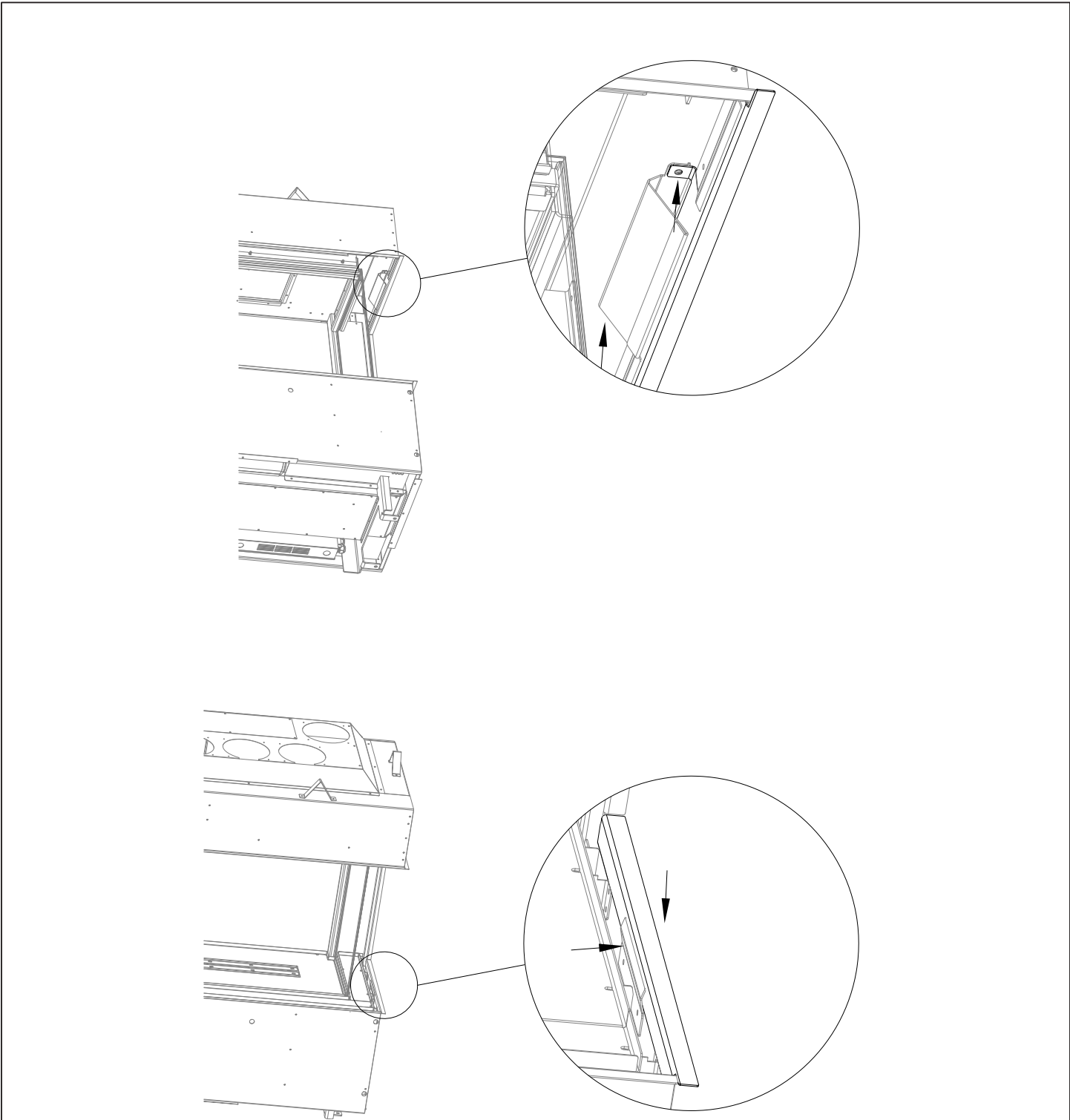

Figure 1.2 - 2-Sided (Corner) or 3-Sided (Bay) Fireplace Conversion

1.1 Converting the Single-Sided to a Corner or Three-Sided (Bay) Fireplace Conversion (continued)

Each conversion kit will include (1) glass edge cover. Figure 1.3 shows the installation of this cover in a right corner application. The purpose of this cover is to provide a finished appearance on the back edge of the glass.

Positioning the glass edge cover.

The pre-bent flange goes to the backside of the firebox glass. Bend the top alignment tab to a 90° angle so it will rest on the top side of the glass. Bend the bottom tab to 180° so it is flat against the cover. The magnets will align with the back edge of the glass and secure the cover.

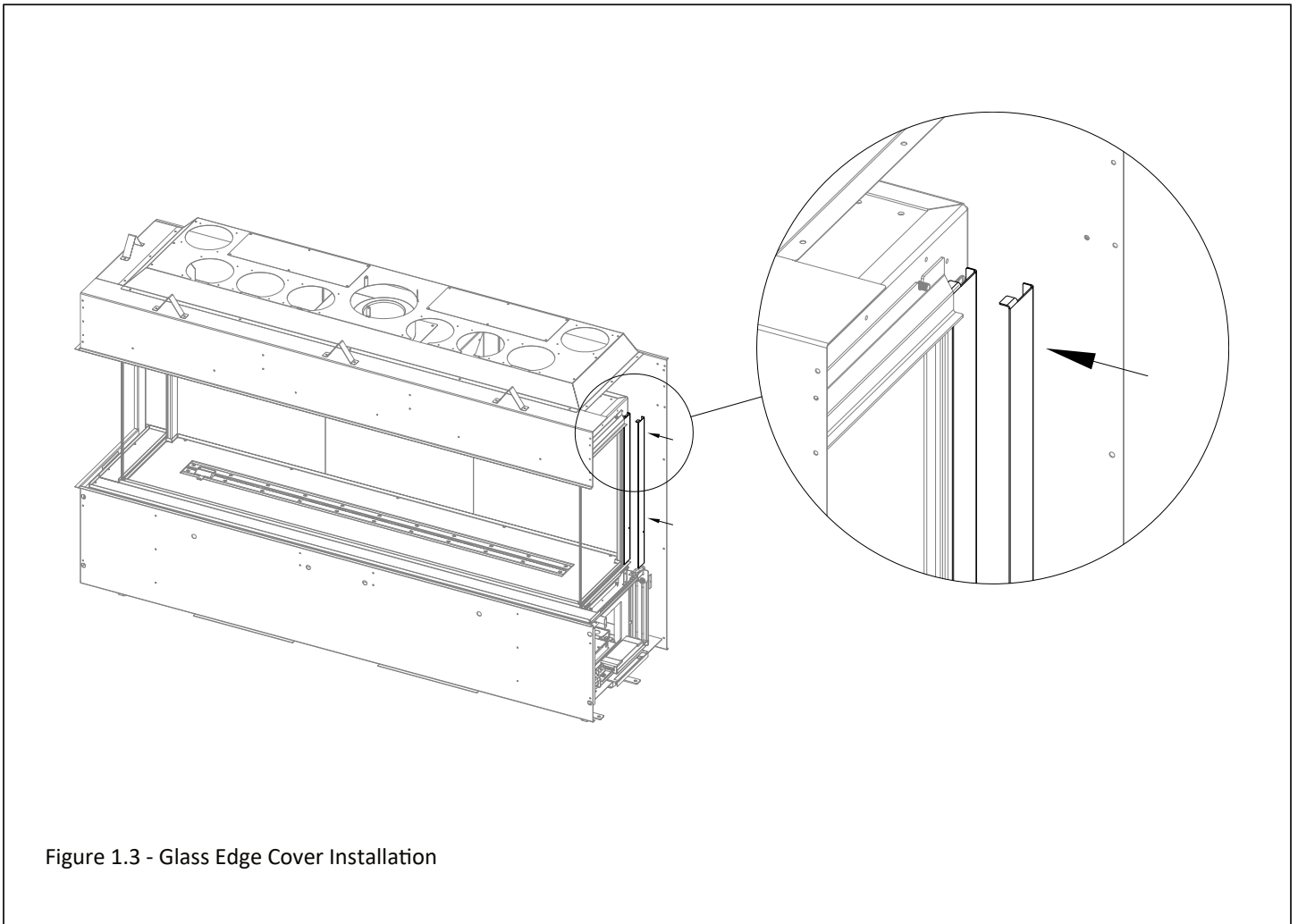

Figure 1.3 - Glass Edge Cover Installation

1.2 Safety Glass Barriers

WARNING: A barrier designed to reduce the risk of burns from the hot viewing glass is provided with this appliance and shall be installed for the protection of children and other at-risk individuals.

If the barrier becomes damaged, the barrier shall be replaced with Hussong Mfg.'s barriers for this appliance.

Any glass, guard, or barrier removed for servicing an appliance must be replaced prior to operating the appliance.

The front safety glass barrier ships with the fireplace. When you order the Corner Conversion Kit (Part# GENL-CCK) you will receive (1) side safety glass barrier. You will use this on the side of the fireplace that you want view-able in a corner fireplace installation. You will order (2) Corner Conversion Kits (Part# GENL-CCK) if you want a 3-Sided (Bay) Fireplace.

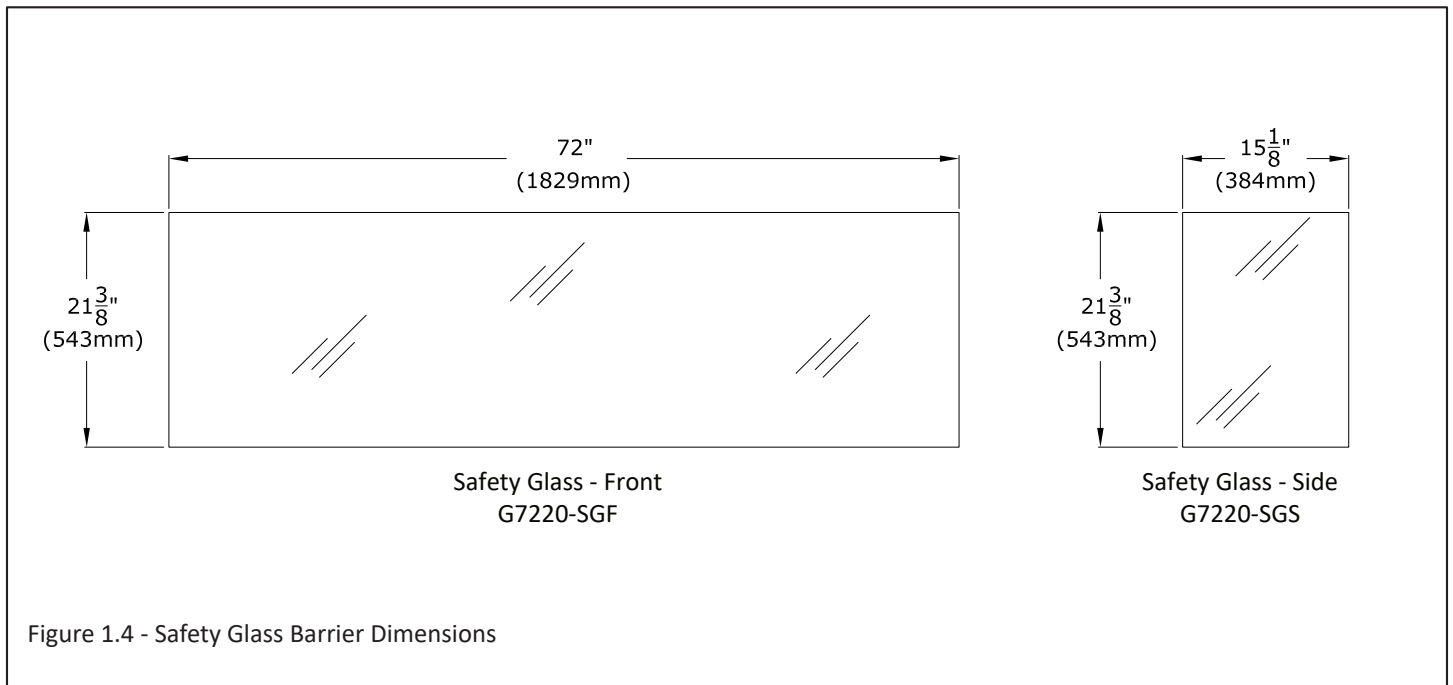

1.3 Typical Corner Fireplace Installations

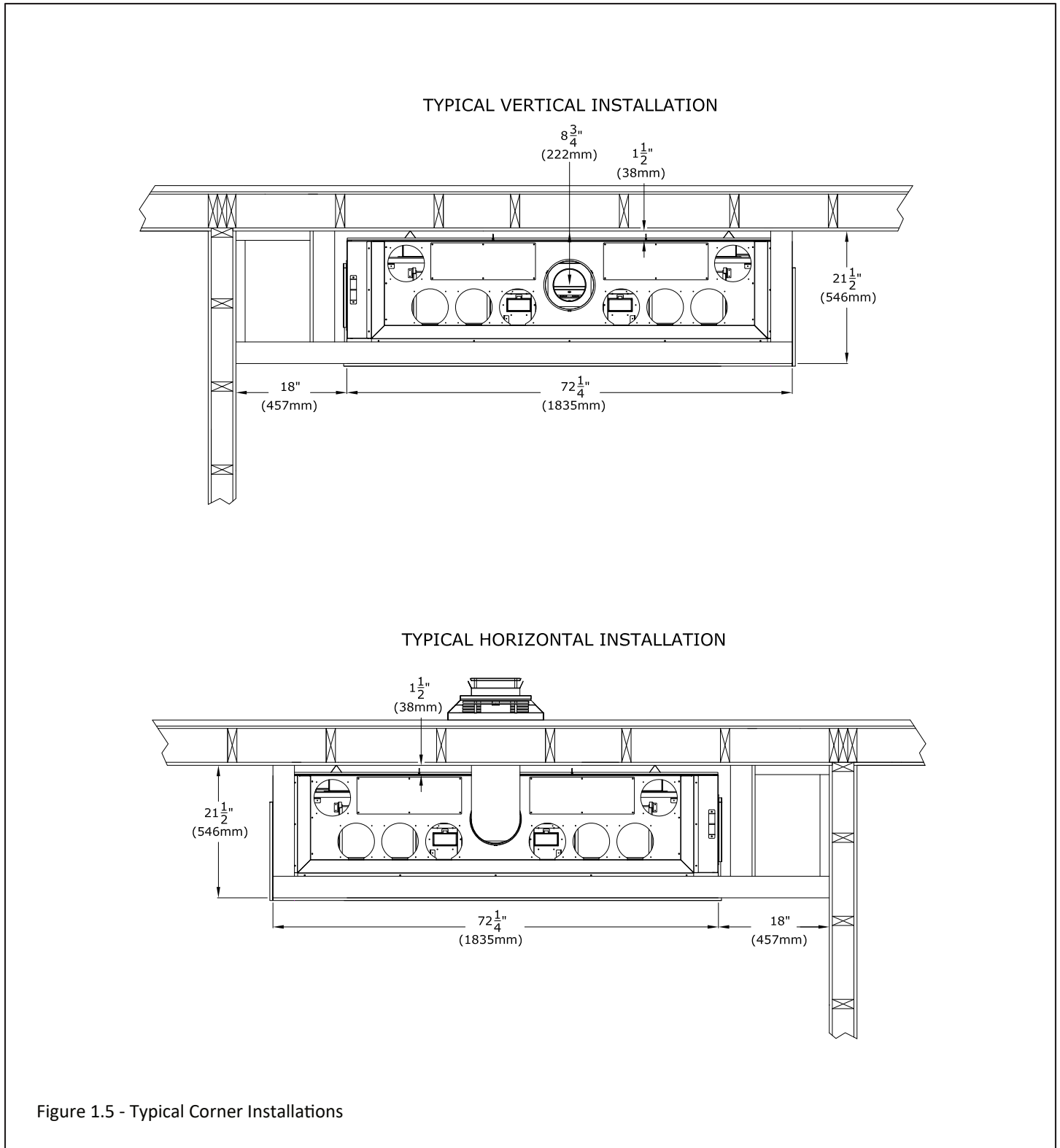

Figure 1.5 - Typical Corner Installations

1.4 Typical 3-Sided (Bay) Fireplace Installations

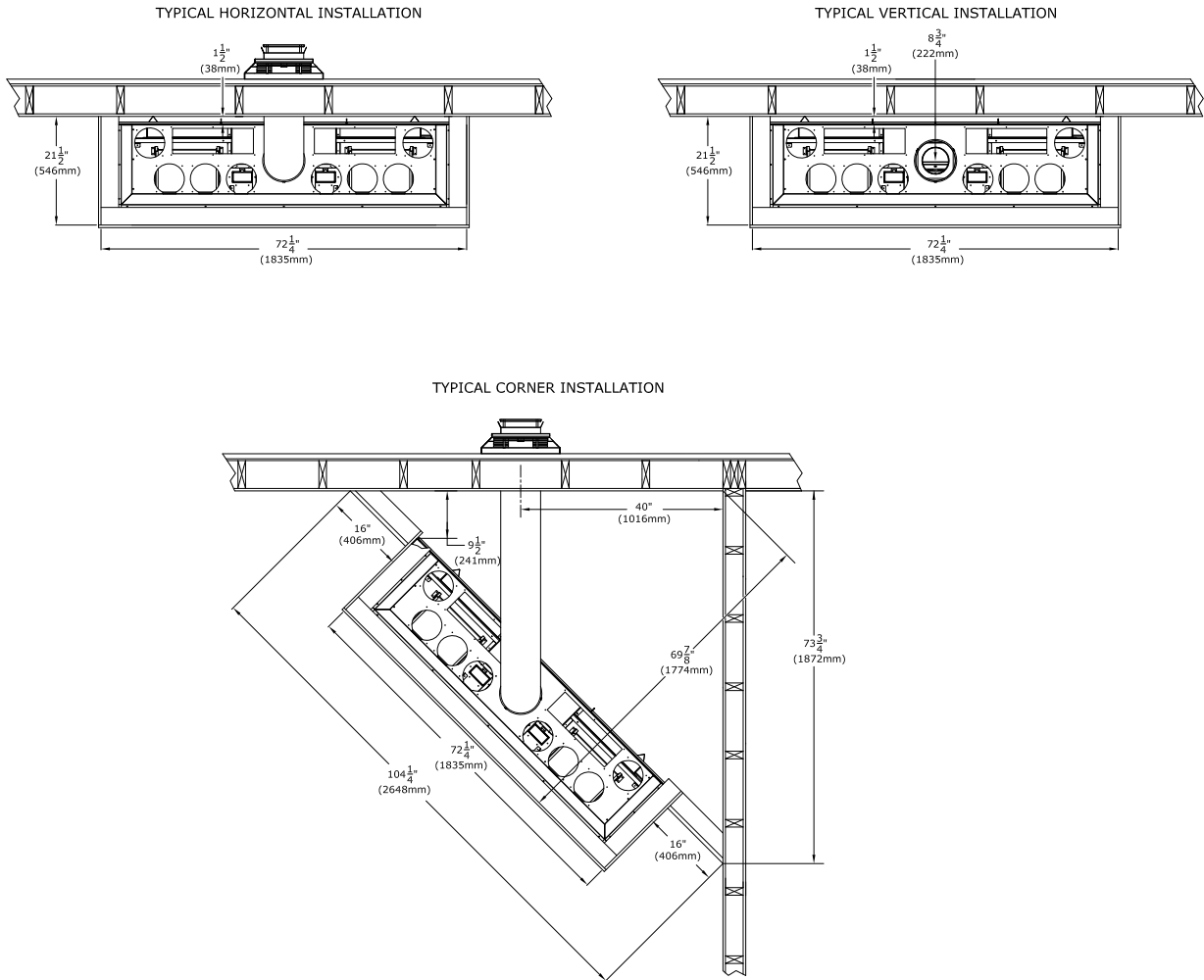

Figure 1.6 - Typical Bay Installations

1.5 Clearances to Combustibles

- See Table 1.1 below for minimum clearances.
- Unless otherwise noted all clearances / images in this manual are based off of nominal 2" x 4" framing being used.

Table 1.1 - Minimum Fireplace Clearances to Combustible Material		
Minimum height of fireplace enclosure	90"	2286mm
Base of fireplace to ceiling	90"	2286mm
From fireplace top stand-off brackets	0"	0mm
From fireplace back stand-off brackets	0"	0mm
From fireplace corners (Bay Installation Only)	9-1/2"	241mm
From fireplace left or right stand-off brackets (nailing flanges) - Corner Installation Only	0"	0mm
From fireplace front	36"	914mm
Fireplace side finishing edge to adjacent sidewall	6-1/2"	165mm
Front and side overhang and/or mantel 16" (406mm) total projection from the top finishing edge of the fireplace	0"	0mm
Unlimited Hearth Extension from the bottom finishing edge of the fireplace	0"	0mm
Minimum Vent System Clearances to Combustible Material Inside Fireplace Enclosure		
Horizontal venting within fireplace enclosure - Top surface of vent pipe	6"	152mm
Horizontal venting within fireplace enclosure - Left, right, and bottom surfaces of vent pipe	1"	25mm
Vertical venting within fireplace enclosure - All surfaces	1"	25mm

1.6 Mounting a Television Above a Fireplace and Television Recess Construction

WARNING: All clearances to venting must be maintained.

- Mounting a television above a fireplace is a common practice. Mantel depth, ceiling heights, and wall and mantel construction material all affect television surface temperatures. Most television manufacturers specify in their instructions that a television should not be installed on, near, or above a heat source.
- We recommend the use of a mantel to deflect heat away from the television.
- Television location rests solely on the homeowner. It is the home owner's responsibility that the preferred TV mounting and mantel design will not exceed the listed maximum operation temperature of their electronic goods.
- The allowed TV recess of 4-1/4" (108mm) measures from the front of the nominal 2x4 framing to the backside of the finishing material of the pocket, as shown in Figure 1.7.

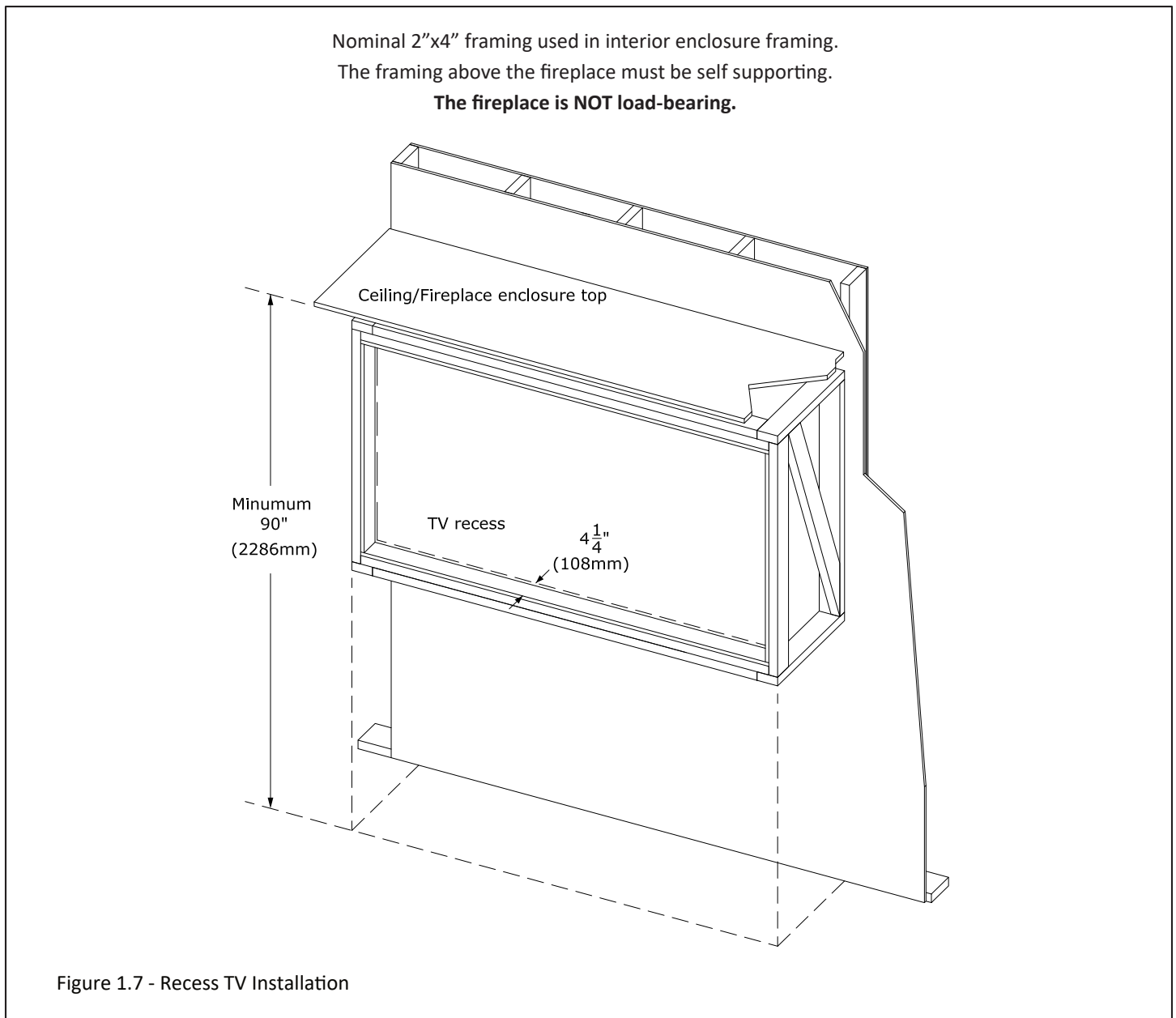

1.6.1 TV Recess with KZK

WARNING: All clearances to venting must be maintained.

- Review all information in Section 1.6 regarding best practices and considerations involving recessing a TV.
- There is specific information about minimum clearances when performing a recessed TV and utilizing a side KZK (left image) or front KZK (right image). The drawing below highlights the minimum framed distance between the KZK framed opening and the framed opening of the TV recess cavity.
- Side KZK option cannot be installed on a left or right corner installation.

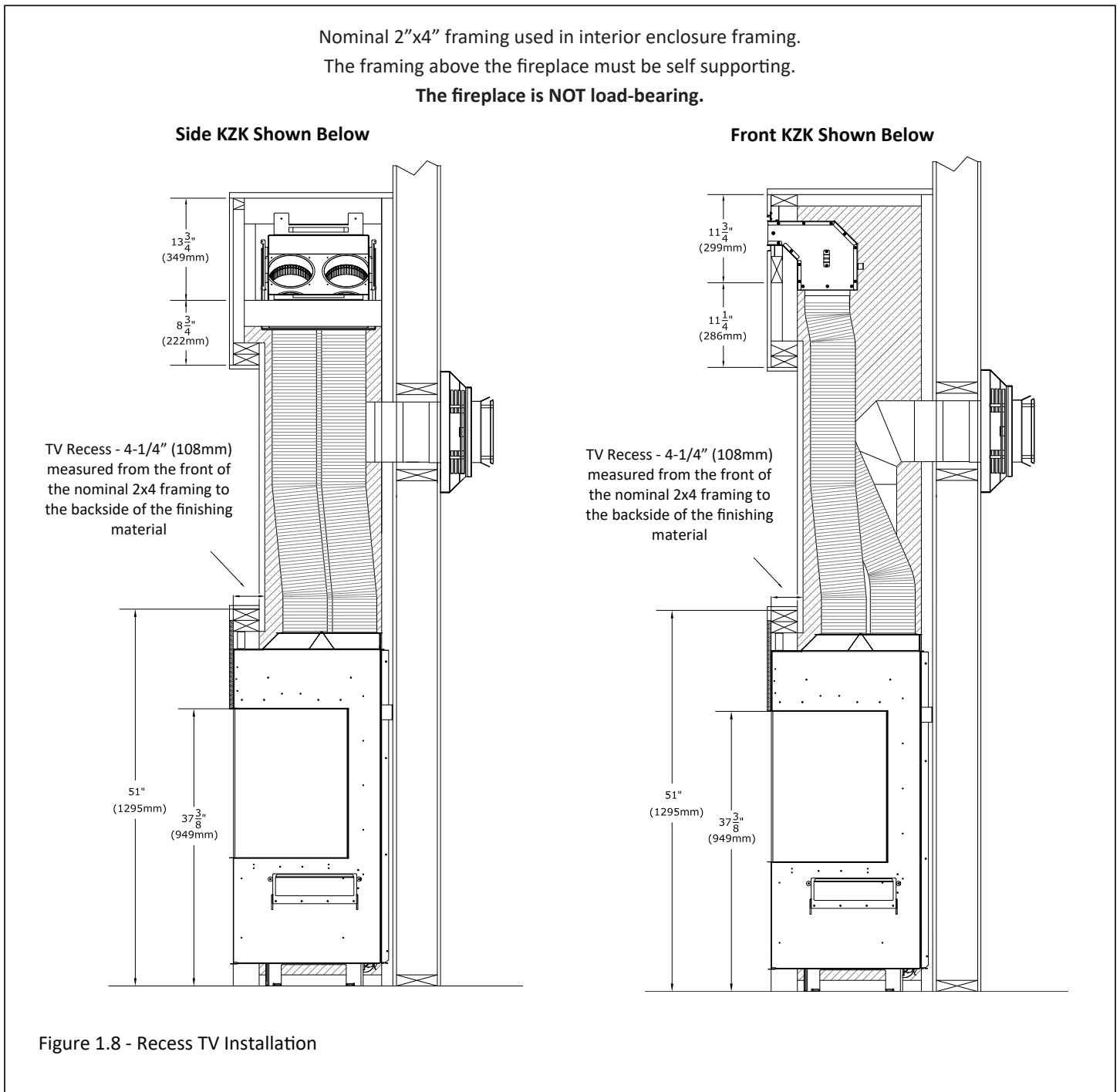

1.7 Elevated Platform Installation

- When planning your installation you may want to elevate the fireplace by building a platform. When you elevate the fireplace you can have the air intake come into the chamber at the floor or be elevated. Having the air intake opening raised off the floor would help prevent debris (e.g. animal hair, kids toys, etc.) from entering the air intake opening.
- If you want the air intake opening to be at the floor you can follow the illustrations in Figure 1.9, Figure 1.11, and Figure 1.12. See more information on the following page.
- If you want to elevate the fireplace and have the air intake opening elevated off the floor as well you can follow the illustration in Figure 1.10. The air intake opening moves with the fireplace where air intake opening starts with the base of the fireplace. Determine the height of the air intake opening you want and build the platform height according to that. The platform should be constructed with a solid plywood base.
- In Figures 1.9 and 1.10 see the following information. Dimension A is the height from the floor you want your air intake opening to start. The finished platform will be this height. Dimension B is the framed height based on your KZK or Vented Cavity selection. Dimension C is the width of the framed opening. Dimension D is the depth of the framed opening. The bottom image in Figure 1.10 shows a 3" (76mm) air intake opening elevated off the floor.

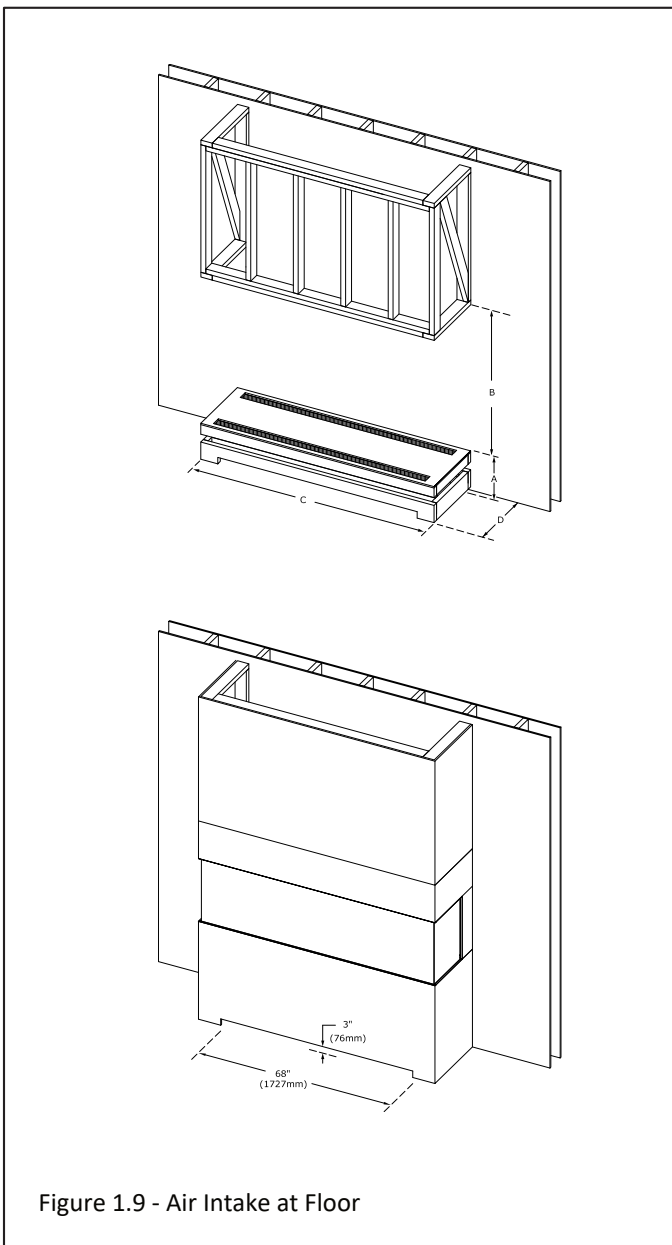

Figure 1.9 - Air Intake at Floor

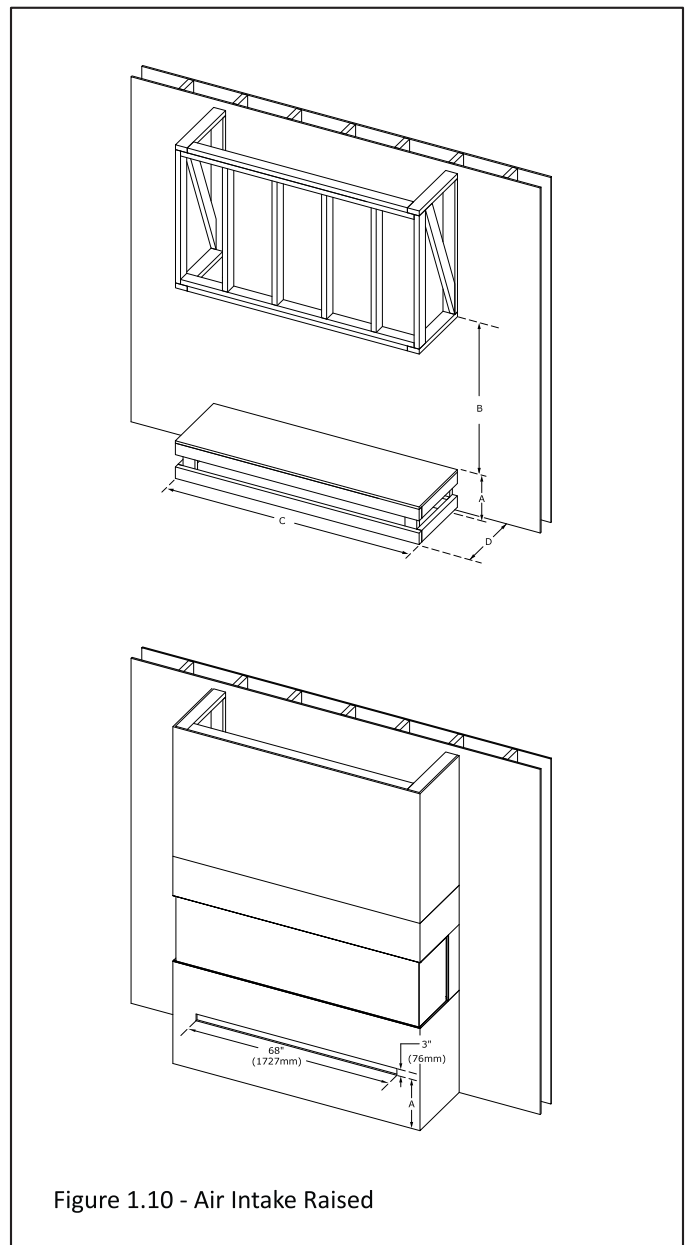

Figure 1.10 - Air Intake Raised

1.7 Elevated Platform Installation (continued)

- If you want to elevate your fireplace but want the air intake opening at the floor or at a lower location than the bottom of the fireplace, there are two items that need to be completed.

Requirement #1 -The fireplace comes with two finishing edge brackets preinstalled at the bottom of the fireplace for the air intake opening. Since you are moving the air intake opening to a position lower than the fireplace you will have to remove the two bottom finishing edge brackets. Each bracket is held on with (2) sheet metal screws. Once removed you can discard. See Figure 1.11.

Requirement #2 - When you construct the fireplace platform follow Figure 1.12. You will leave two 2" x 68" (51mm x 1727mm) openings (one in front and one in back) in the platform base for air supply to the fireplace. These openings feed the front and back fans that cool the safety glass and fireplace chamber. See Figure 1.12.

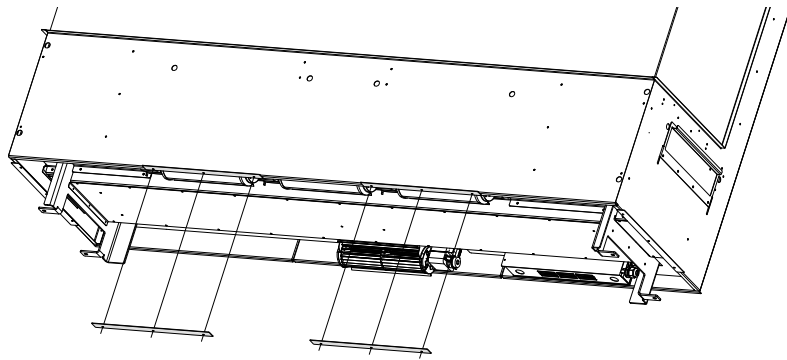

Figure 1.11 - Finishing Bracket Removal

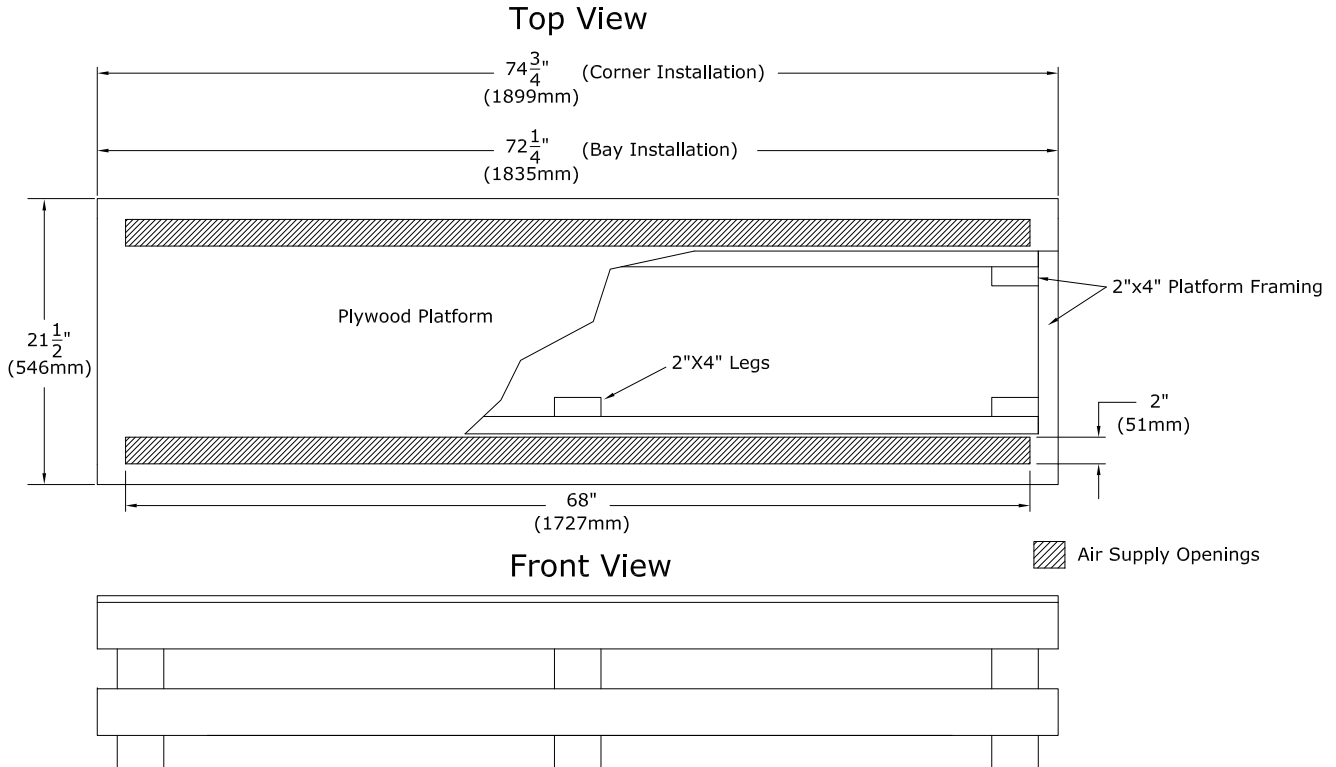

Figure 1.12 - Elevated Platform Air Openings

1.8 How to Hide the Air Intake Opening

We have an option where you can visually hide the air intake. You would install an overhang over the air intake opening. A way to achieve this would be to create a floating hearth. Depending on your desired height of the fireplace, the platform may raise the air intake opening higher than you want. Follow the requirements in Section 1.7 (Specifically Figure 1.11 and 1.12) for an air intake raised off the floor to meet the requirements in this section.

- The left image in Figure 1.13 shows an isometric view of a floating hearth. The dashed lines show the interior void for air flow.
- The top right image in Figure 1.13 shows a cross-section view of this floating hearth indicating the airflow path into the air intake opening of the fireplace chamber.
- The bottom right image in Figure 1.13 shows a cross-section view of this floating hearth with the required clearances. The height of the platform that the fireplace sits upon and the gap from the floor to the bottom of the floating hearth are a minimum of 5" (127mm). The interior void clearance of the overhang to the front of the fireplace is a minimum of 3" (76mm). The overhang can cover the air intake opening with a maximum of 3" (76mm) overhang. The bottom of the overhang (floating hearth) must be flush with the platform where the fireplace legs rest upon. The clearance of the floating hearth to the floor must match the height of the platform.

IMPORTANT: This installation option is NOT approved for Side KZK Part # KZK-1510B. This installation option is approved for the Front KZK Part # KZK-068 and all the Vented Cavity Options.

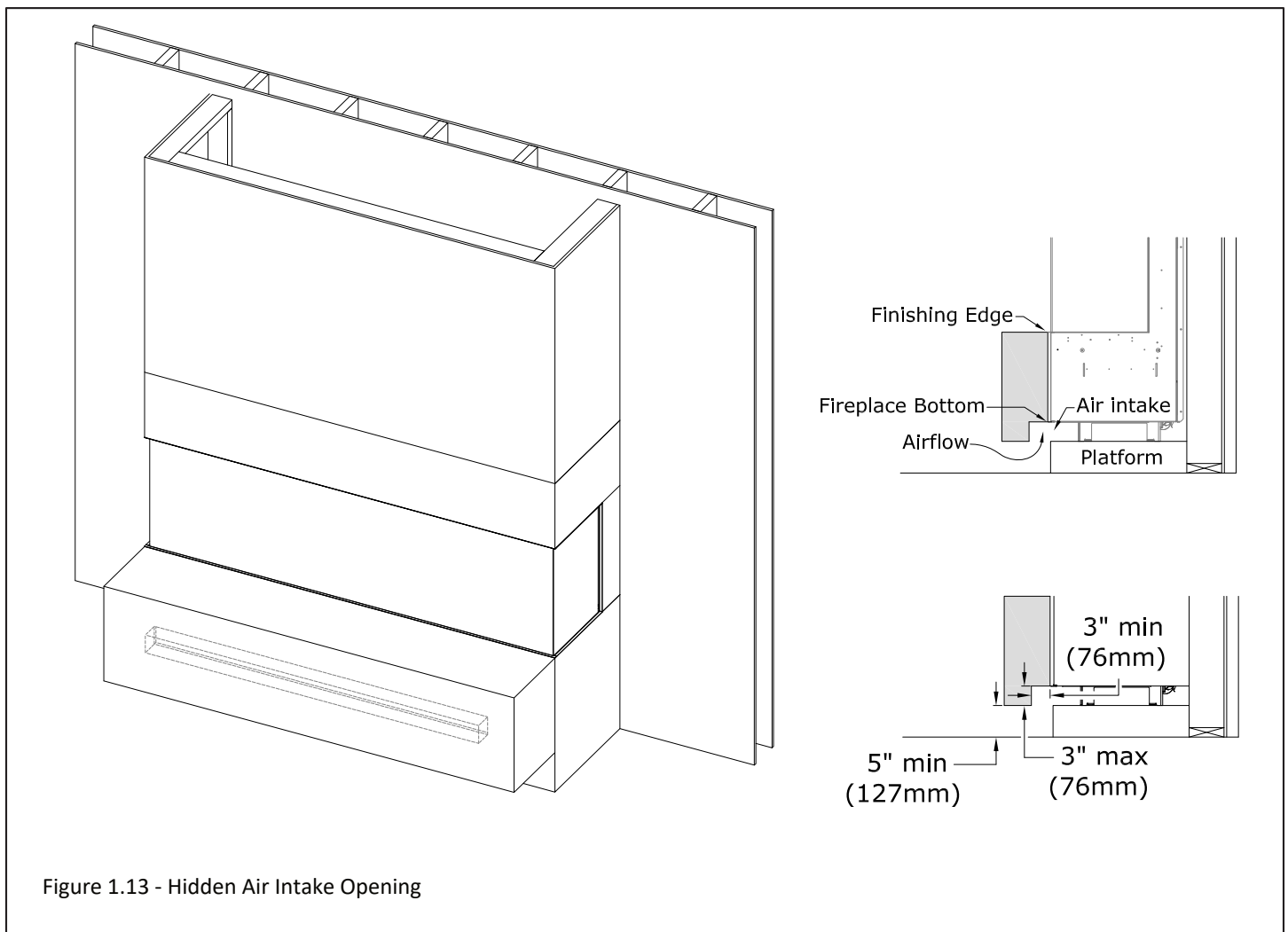

1.9 Clearance to Sprinkler

- In a situation where a sprinkler head is installed within the proximity to a #KZK discharge opening or the vented cavity opening for the fireplace chamber, the diagram below MUST be followed.
- The distance between a sprinkler head and discharge opening cannot be less than 60" (1524mm) in length at every point from the origin of the discharge opening. You must also verify the sprinkler head sensor is set to the proper heat setting so it does not activate when the room heats up from the fireplace being operated normally.
- Please follow local building codes to determine what temperature setting is relevant for your installation.
- Figure 1.14 shows a side KZK whereas your installation may look different.

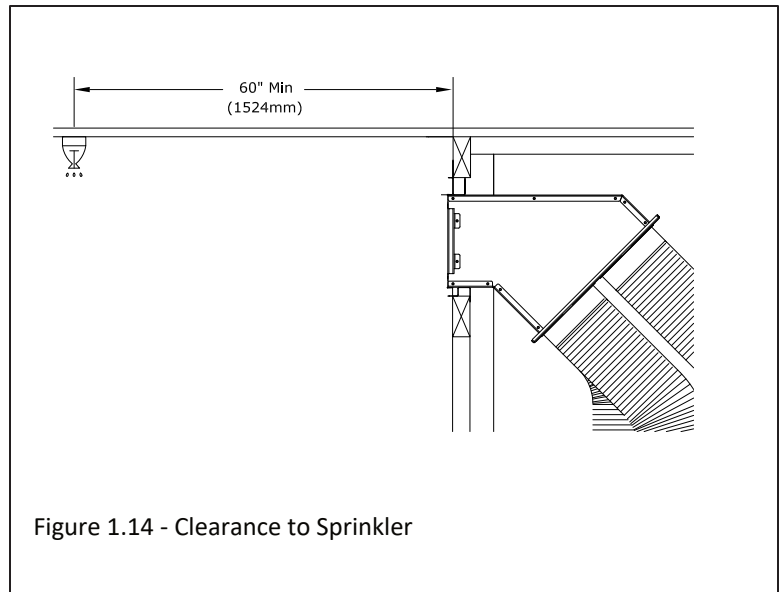

Figure 1.14 - Clearance to Sprinkler

1.10 Wall Thimble Framing Instructions - Minimum Horizontal

- Follow Figure 1.15 for minimum rough-in dimensions.
1. Measure from floor level of the fireplace to the center of where the vent pipe will penetrate the wall. The dimensions in Figure 1.15 are used with Simpson DuraVent vent pipe.
 2. Cut and frame an opening in the wall to allow the vent system at least $\frac{1}{4}$ " (6mm) rise for every 12" (305mm) of travel up to the wall thimble.
 3. Follow the vent pipe manufacturer's installation instructions for natural draft vent installation.

Note: Vent pipe framing dimensions are tested with listed Simpson DuraVent vent pipe. Other manufacturers product dimensions may vary.

Minimum Wall Thimble clearance for 5" x 8" vent pipe is $\frac{1}{2}$ " (13mm).

Minimum Wall Thimble clearance for 4" x 6-5/8" vent pipe is 1" (25mm). The Kozy Power Vent is the only approved 4" x 6-5/8" horizontal termination.

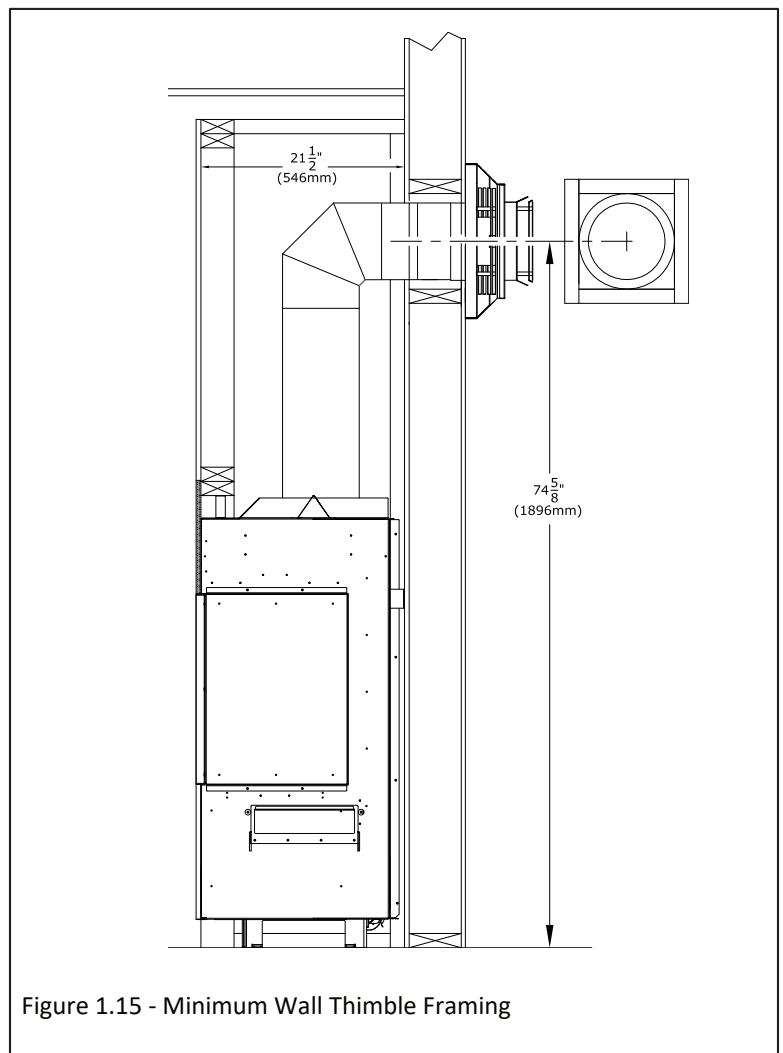

Figure 1.15 - Minimum Wall Thimble Framing

2.0 Corner Installation

The information provided in this section will cover topics related to installing this fireplace in its corner configuration (left or right). The topics include: framing, facing material, finishing material, cooling the fireplace chamber, and chamber clearances.

2.1 Framing

Note: Unless otherwise noted all clearances / images in this manual are based off of nominal 2" x 4" framing being used.

IMPORTANT: The framing above the fireplace must be self supporting in all installation scenarios. The fireplace is not load-bearing.

WARNING: Provide adequate clearances around air openings into the combustion chamber. Provide adequate clearance in front of the fireplace for safety glass barrier removal, component access, gas line installation, service access, etc.

CAUTION: Cold air transfer area. The surround fireplace chase must comply with all clearances as outlined in this manual, and be constructed in compliance with local building codes. Outside walls should be insulated to prevent cold air from entering room.

- Floor protection in front of the fireplace is not required. Combustible material may be used if installing a hearth extension. Consider the thickness of the hearth extension finishing material if building a fireplace platform. The hearth may be flush with the bottom finishing edge of the fireplace.
- The bottom of the fireplace must be placed directly on a wood or non-combustible surface (not linoleum or carpet). If this appliance is to be installed directly on carpeting, tile, or other combustible material other than wood flooring, this appliance shall be installed on a metal or wood panel extending the full width and depth of the appliance.

IMPORTANT: To cool the fireplace chamber correctly take important consideration when planning out the framing for this fireplace. Look at the different options on how to cool the chamber that are outlined in Section 2.4. You must choose one of the KZK (Komfort Zone Kit) or Vented Cavity options. The framing will have to accommodate one of these chamber cooling options.

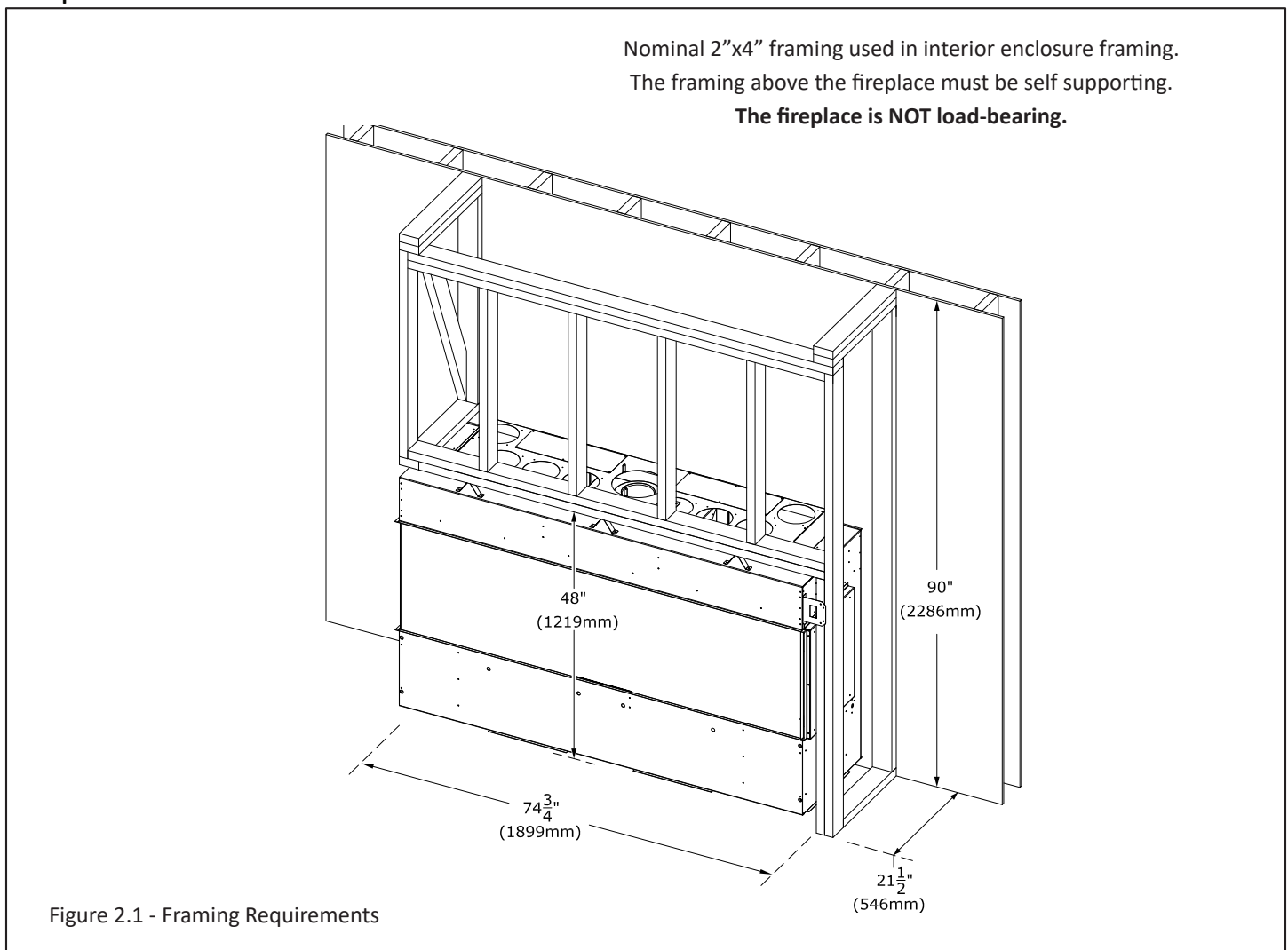

2.2 Recessed Fireplace Framing

WARNING: All clearances to venting must be maintained.

- It may be desirable to recess the fireplace into a false wall so the finishing material is next to the side glass.
- It is necessary to accommodate the thickness of the facing and finishing material when determining the framing.
- The measurement from the back of the chamber (fireplace back stand-off) to the rear side finishing edge is 5-7/8" (149mm), which corresponds to Dimension A, shown in Figure 2.2.
 - Example: If your facing material and finishing material comes out to 1" (25mm) then your framing would be 4-7/8" (124mm) from the back of the chamber. Your finishing material would tuck behind the rear side finishing edge.
- In Figure 2.2 dimension A is the recessed framed depth of the false wall.
- **Only a front KZK (Komfort Zone Kit) or front Vented Cavity is allowed when installing the fireplace in a recessed installation option.**

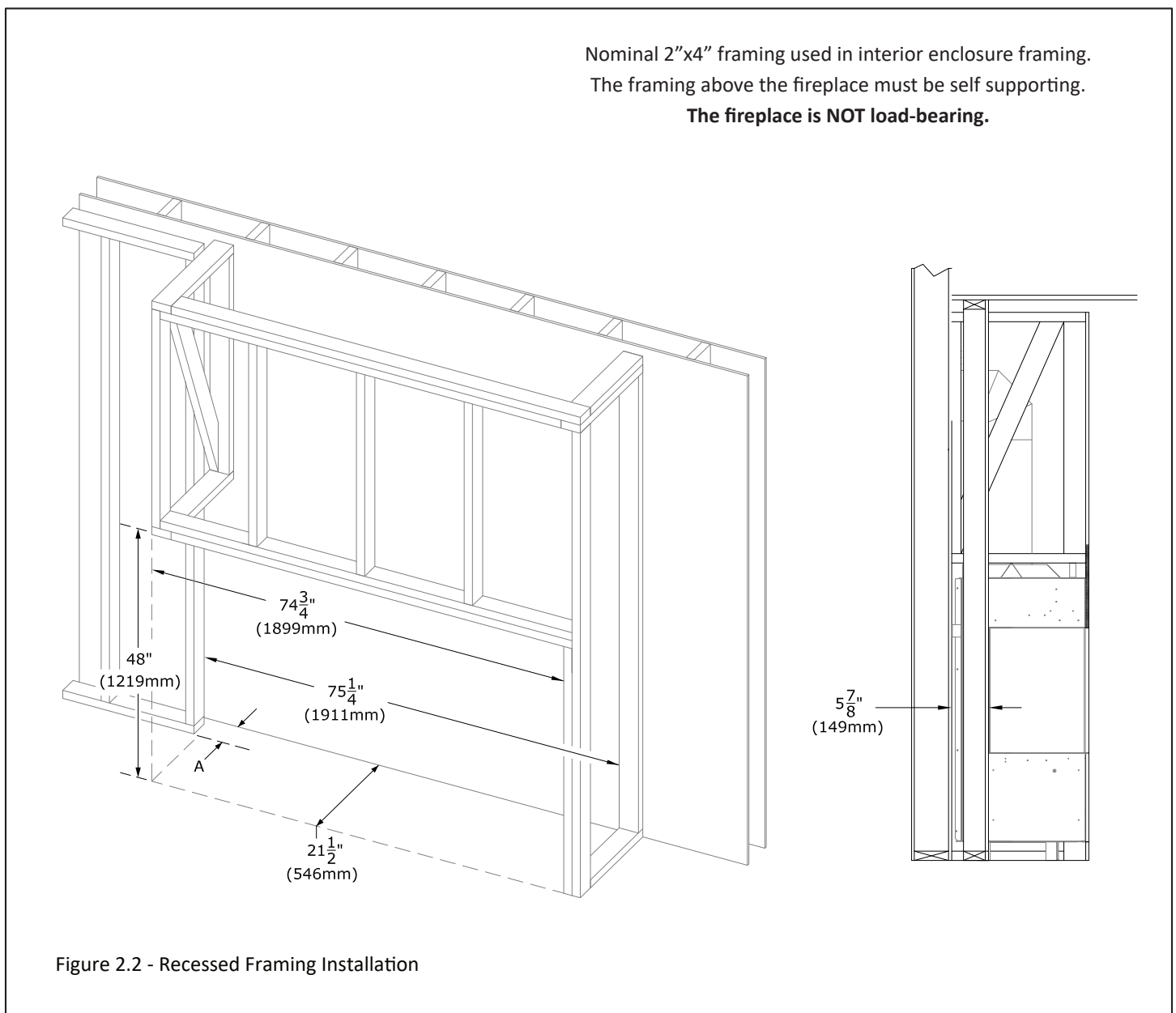

2.2 Recessed Fireplace Framing (continued)

- Figure 2.3 shows how to face the fireplace chamber when installing the fireplace in a recessed application. You are required to first face the fireplace chamber then build the wall off to the side.
- Follow all non-combustible facing requirements in Section 2.3 before building the walls off to the side. The required non-combustible material prevents the combustible framing of the recessed wall from touching the fireplace.

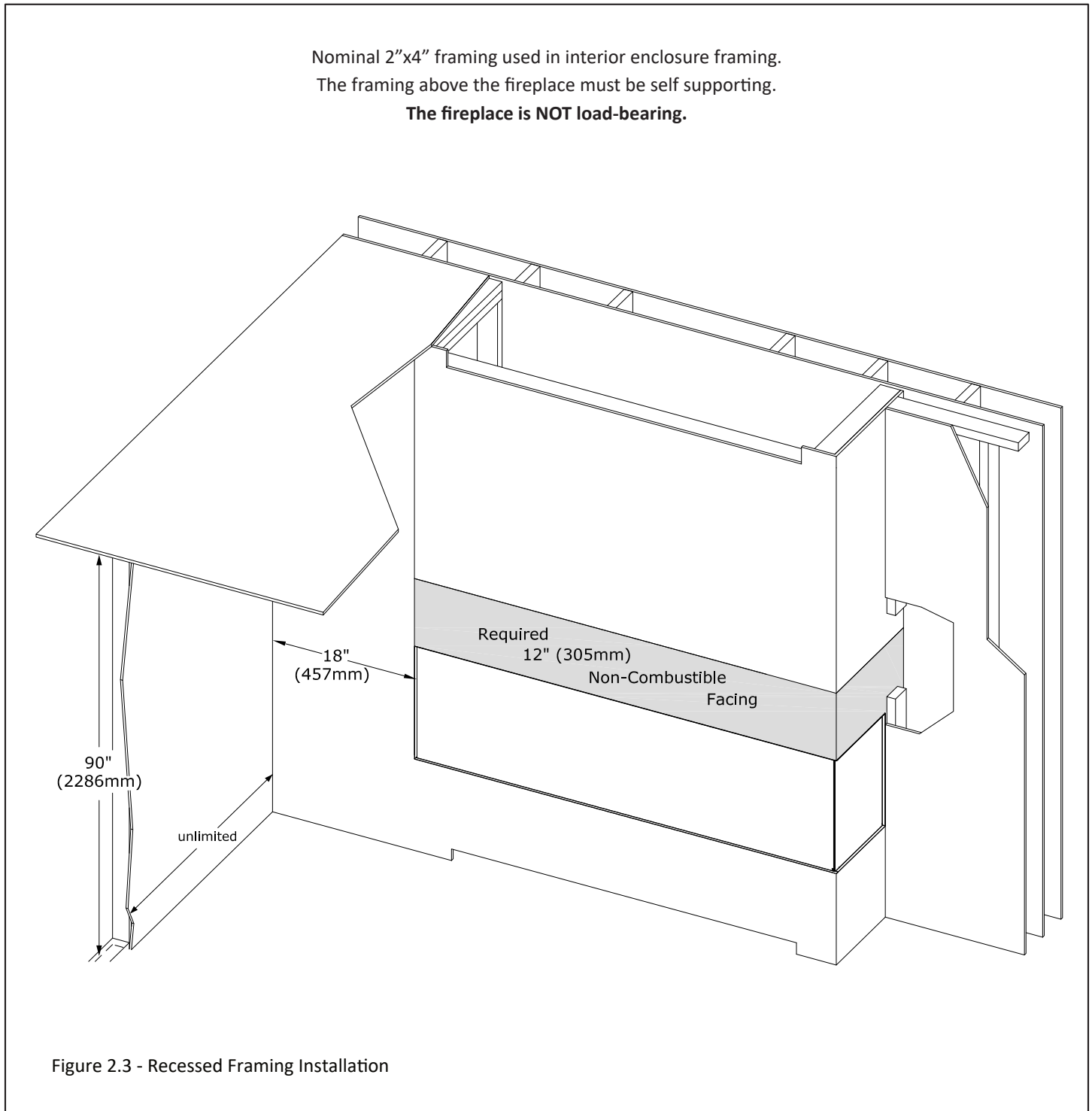

2.3 Facing Requirements

The information in this section shows the minimum non-combustible facing requirements. These requirements apply for vented cavity or KZK installations. Figure 2.4 shows the minimum 12" (305mm) non-combustible facing material above the fireplace top finishing edge.

Take special consideration where you attach the facing material to the fireplace as there are no-screw zones on this fireplace. The image below shows three no screw zones for the facing and finishing material. There is a 1" (25mm) zone below the fireplace bottom finishing edge and a 2-3/8" (60mm) zone above the fireplace top finishing edge. The third location is 45-1/2" (1156mm) x 4-1/4" (108mm) centered above the air intake opening.

Make sure the screws only penetrate up to 1/2" (13mm) into the allowed areas of the fireplace. Take consideration of this when choosing screw length based on your facing material thickness.

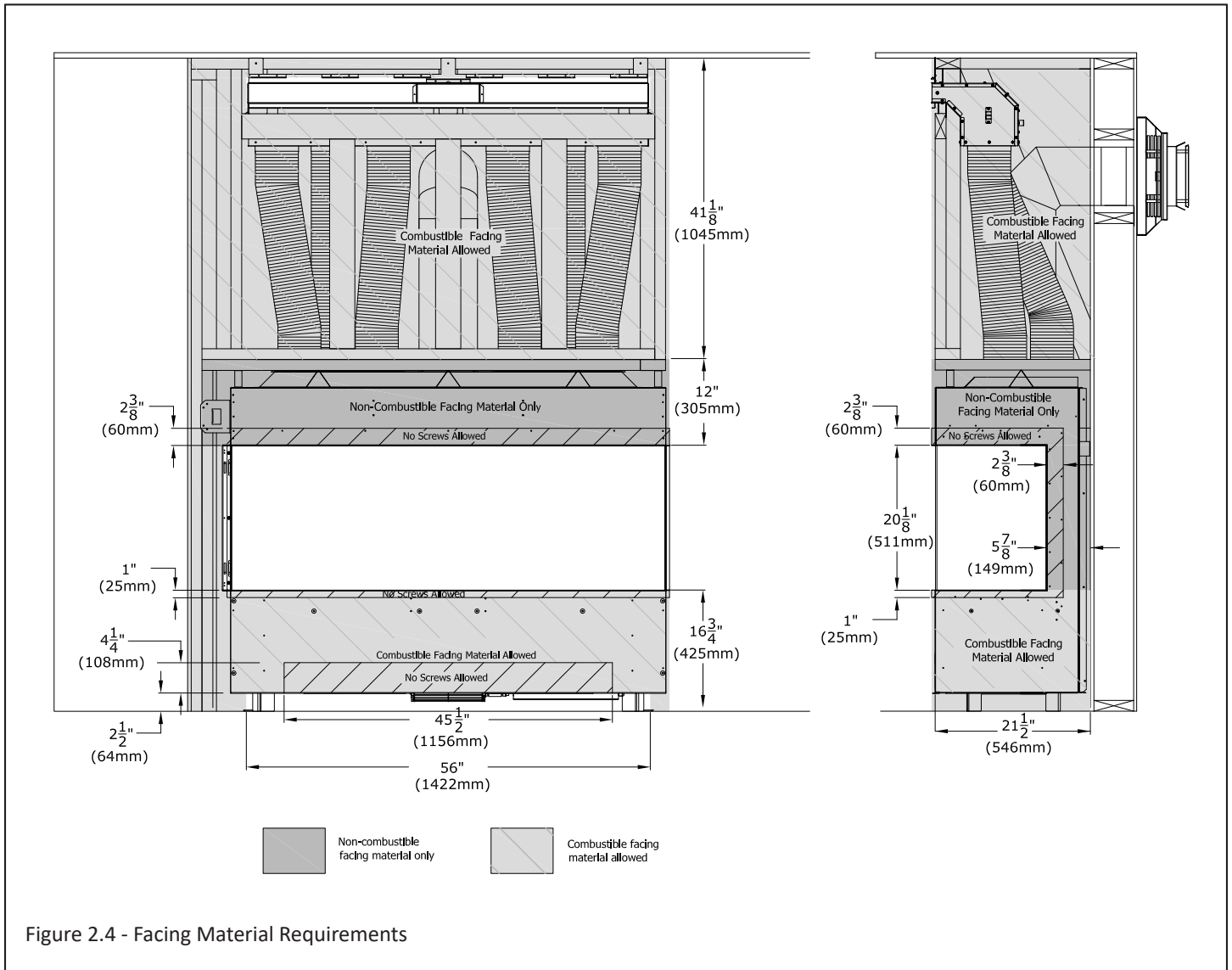

Figure 2.4 - Facing Material Requirements

2.4 Requirements to Cool the Fireplace Chamber and Safety Glass Barriers

IMPORTANT: This fireplace requires that the fireplace chamber has airflow to cool it. You must choose one of the options in this section to cool the fireplace chamber. You must select and follow the requirements of one of the options in this section that use an air intake opening with a vented cavity heat release opening or KZK heat release.

The air intake opening supplies the necessary room air to cool the chamber and safety glass barrier. The Vented Cavity or KZK heat release opening discharges the warm air from the chamber and fireplace. This airflow is separate from the air that is used in the vent system and combustion process.

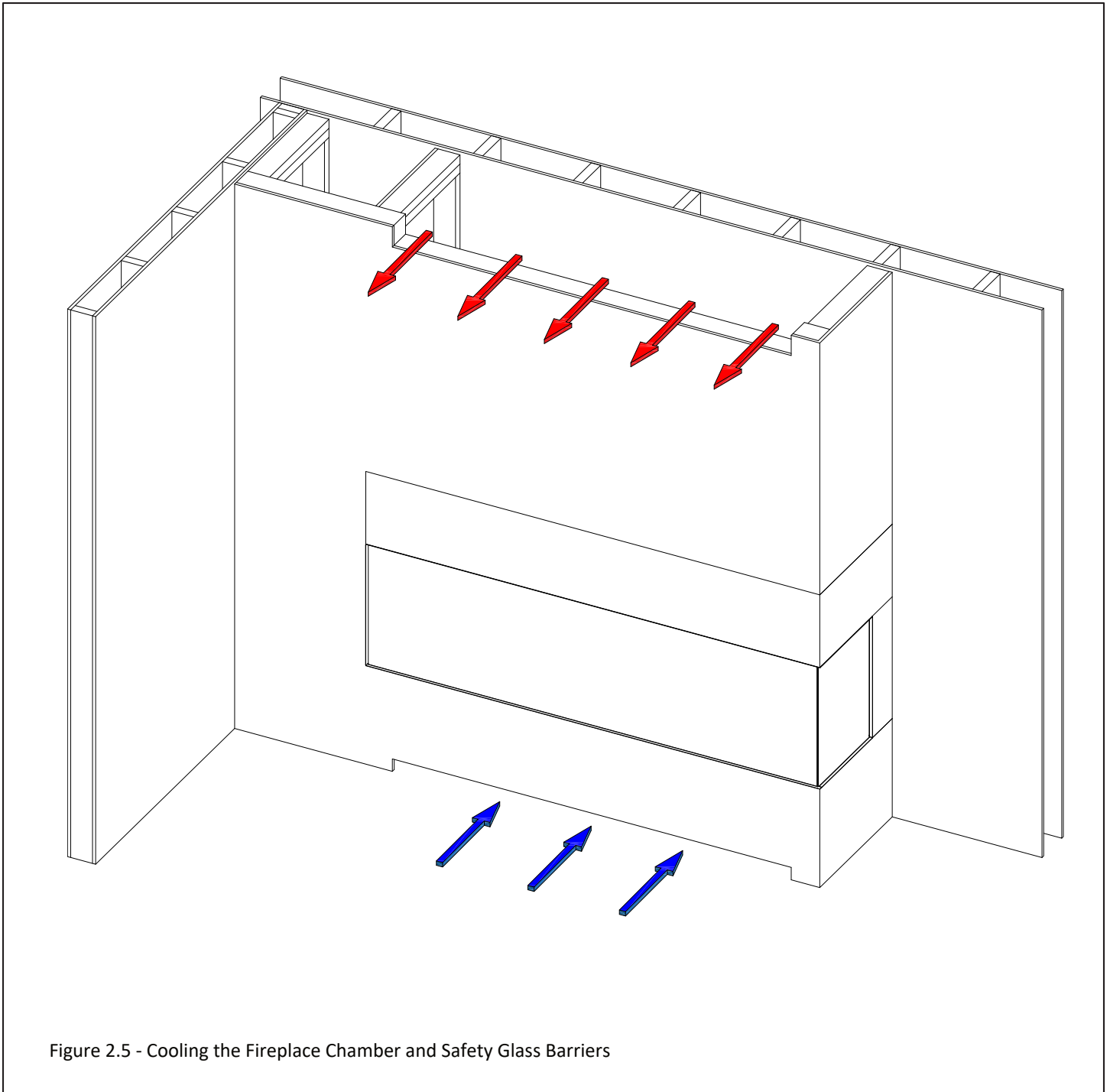

Figure 2.5 - Cooling the Fireplace Chamber and Safety Glass Barriers

2.4.1 KZK Installation Overview

Note: the KZK collars cannot be installed on the fireplace when sliding the fireplace into the framed opening. Install after installing into the framed opening.

1. Slide the fireplace into the framed opening. Ensure the two rectangle rear cover plates stay installed on the fireplace.
2. Use the (32) provided sheet metal screws to install the (8) KZK collars on the top of the fireplace.
3. Frame the rough opening of the KZK plenum(s). Refer to all pages of this manual to ensure all framing and finishing materials are considered.
4. Install the plenum(s) into the rough framed opening to maintain minimum clearances to combustibles. If you are installing the front KZK we recommend using the supplied plenum support brackets to help support the weight of the plenum and air duct pipes. Ensure the plenum(s) are level (All KZK Options) and their outlet(s) are not distorted. Additional metal strapping may be needed to support the weight of the air duct pipes depending on the height of installation.
5. Attach the air duct pipes from all (8) plenum vent collars to all (8) fireplace vent collars. An upward slope must be maintained in horizontal section of air duct pipes for proper convection.
6. Install the KZK discharge trim or KZK grilles provided with this kit using the provided screws. If desired, the discharge trim or grilles may be painted using high temperature paint (250F or 121°C). Continue with fireplace installation.

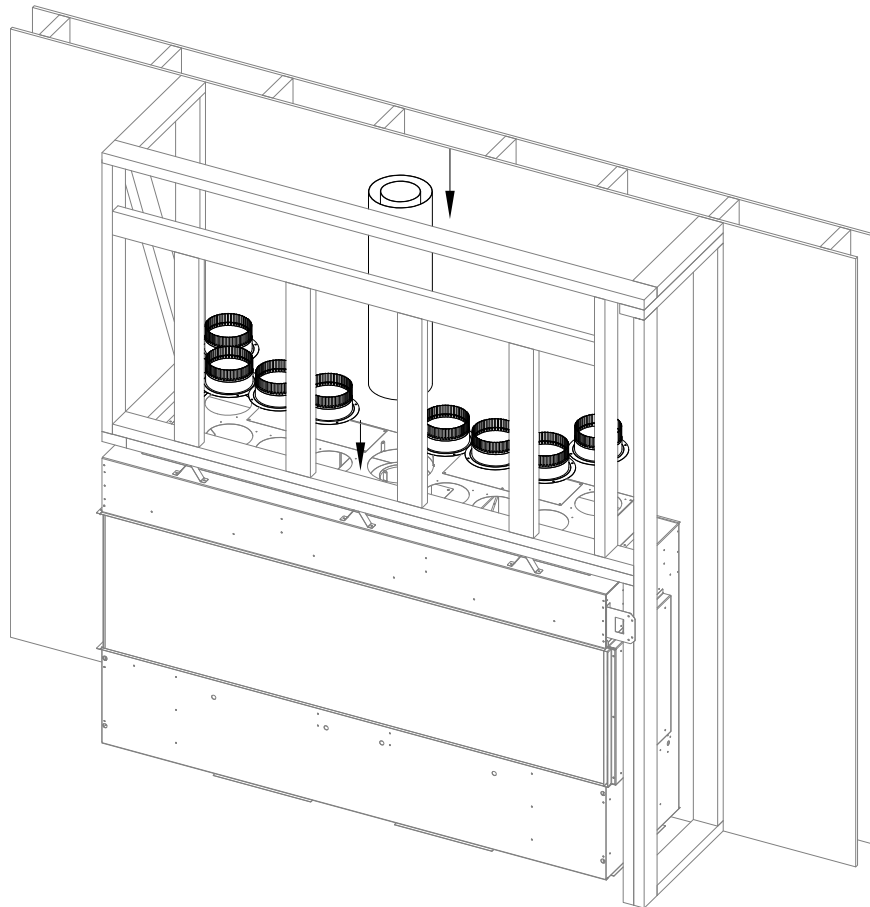

Figure 2.6 - KZK Collar Installation

2.4.2 Front KZK - Part # KZK-068

This section outlines the requirements for using the front KZK option to cool the fireplace chamber. This option requires the use of an air intake opening in the fireplace chamber and the installation of the front KZK.

Kit Contents

ALL kit contents must be installed.

- (1) 68" plenum kit: KZK-068
- (1) plenum discharge trim: KZK-068DT
- (2) plenum support brackets
- (16) 6" collars - (8) attach to the bottom of the plenum; (8) attach to the top of the fireplace.

Additional Required Items

- (2) KZK-410-6 kits (sold separately) are used for a vent run up to 10' (3m). If you are mounting the plenum above the fire-place 10' (3m) or less, use (2) KZK-410-6 kits.

Optional Items

If you are mounting the plenum above the fireplace between 10' (3m) to 20' (6.1m), you will need a total of (4) KZK-410-6 kits and (2) #KZK-CPL6 coupler kits. The (2) KZK-CPL6 coupler kits (sold separately) include the 6" couplers that connect (4) KZK-410-6 kits together.

Plenum Placement

- **IMPORTANT:** The air duct pipes cannot run horizontally without a vertical rise.
- **IMPORTANT:** The 1/2" (13mm) clearance around the air duct pipes must be maintained.
- Use (2) #KZK-410-6 kits UL181 (or Class 0 Air Duct piping) to connect the plenum to the unit.
- Hussong Mfg. Co., Inc. requires pipes to be listed as UL181 Class 0 Air Duct to connect the plenum to the unit.
- Maximum Vent Run: 20' (6.10m)

(8) - 10' x 6" (aluminum flex) listed to UL-181 Class 0 Air Duct (sold separately)

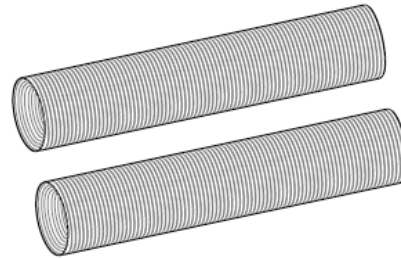

Figure 2.7 - #KZK-410-6 - QTY of 2 kits

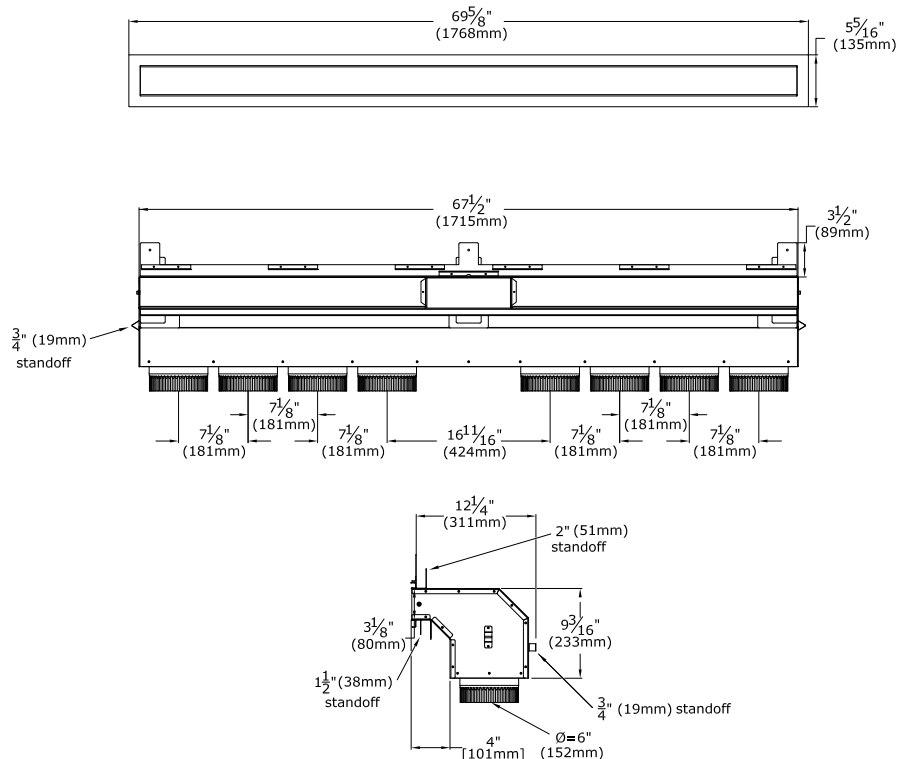
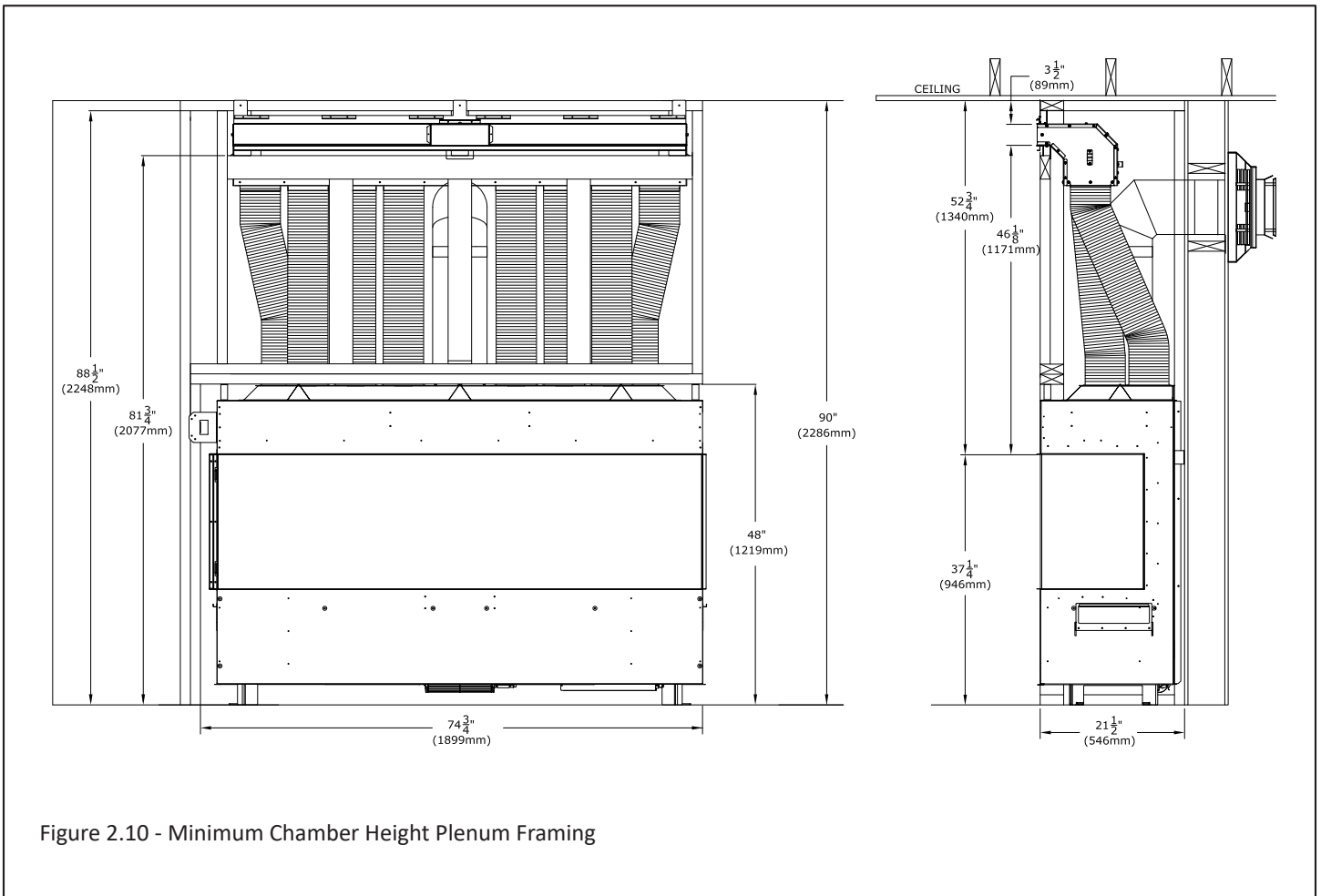
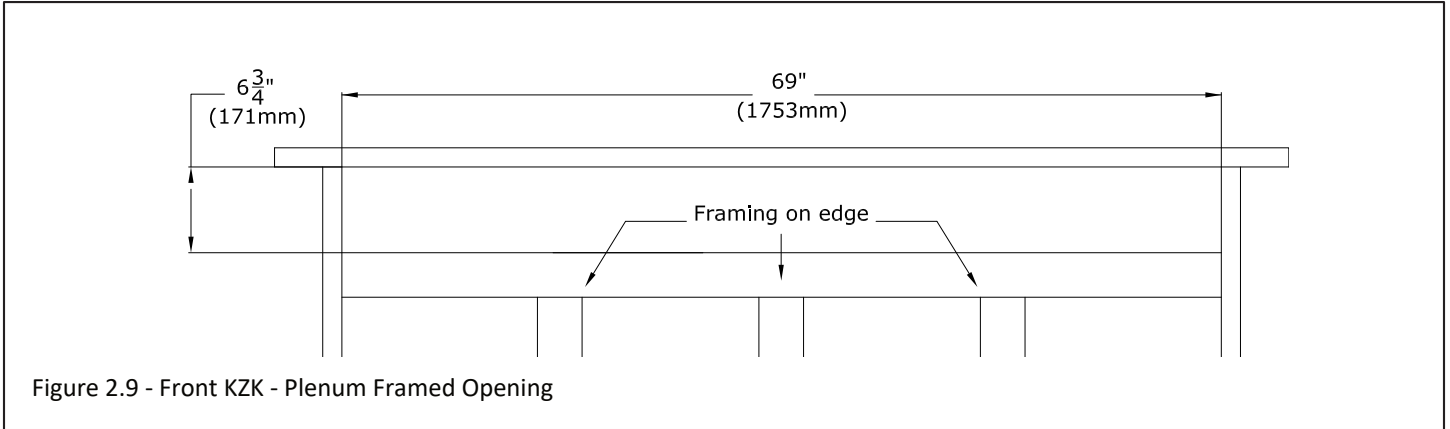

Figure 2.8 - KZK-068 Overview

2.4.2 Front KZK (continued)

Below is the framing information for the front KZK. Figure 2.9 shows the framed opening for the KZK plenum. Figure 2.10 shows the framing information.



2.4.2 Front KZK (continued)

Figure 2.11 shows the minimum air intake opening that is required for the front KZK installation.

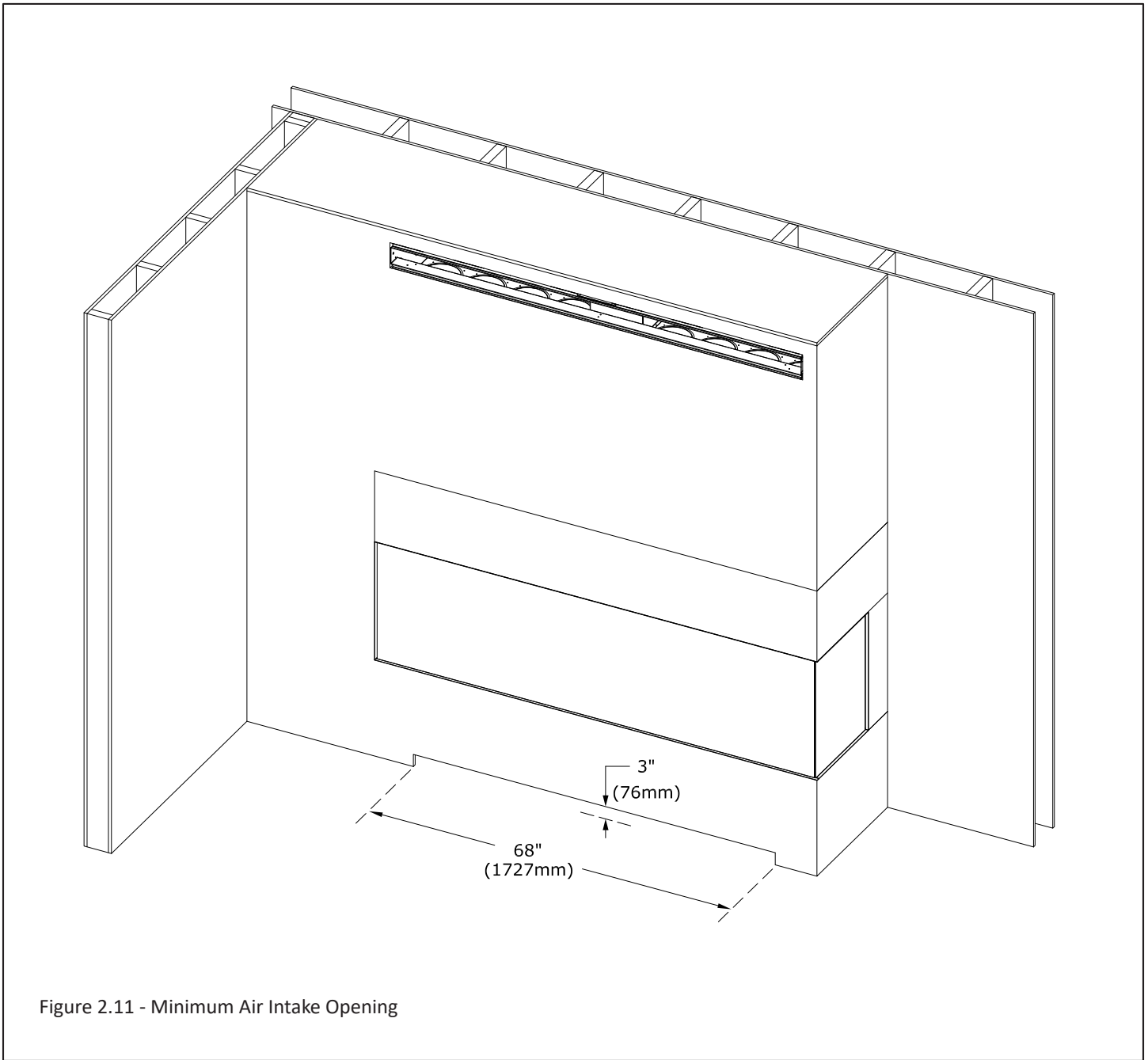

Figure 2.11 - Minimum Air Intake Opening

2.4.2 Front KZK (continued)

Shown below in Figure 2.12 are options on how you can finish around the front KZK plenum opening.

- The left image shows combustible facing material such as drywall finished up to the standoffs around the opening of the plenum. Install the KZK discharge trim to cover the edge of the finishing material.
- The middle image shows the allowed 1" (25mm) thick additional combustible finishing material such as shiplap. This material must stop at the edge of the discharge trim.
- The right image shows non-combustible finishing material such as tile that is finished up to the opening of the plenum.

Shown below in Figure 2.13 are options on how you can finish up to finishing edge of the air intake opening. Ensure the 3" (76mm) air intake opening is always maintained throughout all the facing and finishing material.

- The left image shows the 1/2" (13mm) facing material butting up against the finishing edge at the fireplace bottom.
- The middle image shows the allowed 1" (25mm) thick additional combustible finishing material such as shiplap.
- The right image shows non-combustible finishing material such as tile or stone.

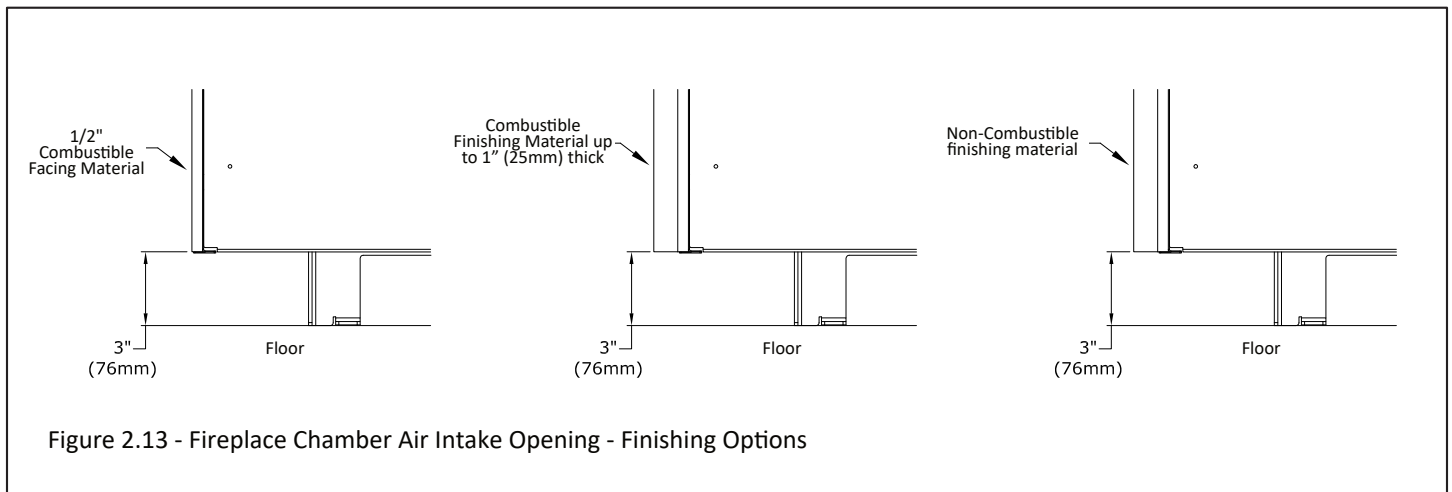
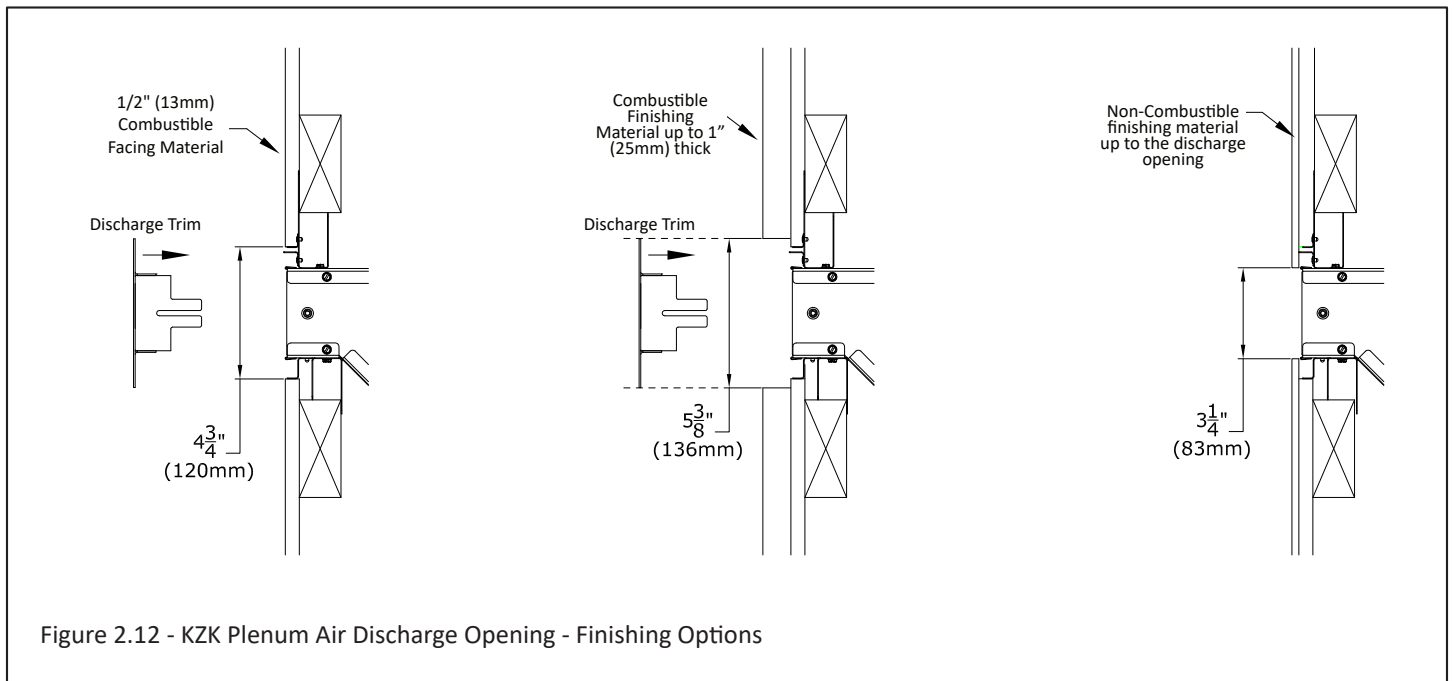

2.4.3 Vented Cavity Installation Overview

1. The fireplace ships ready for the vented cavity installation scenario shown in Section 2.4.4. Leave the rectangle cover plates installed on the fireplace.
2. Slide the fireplace into the framed opening.
3. Frame the rough opening of the vented cavity option you have chosen to maintain minimum clearances to combustibles.

**Corner Installation (Left or Right Corner) -
Cover plates must stay installed on the
fireplace for vented cavity installations
shown in Section 2.4.4.**

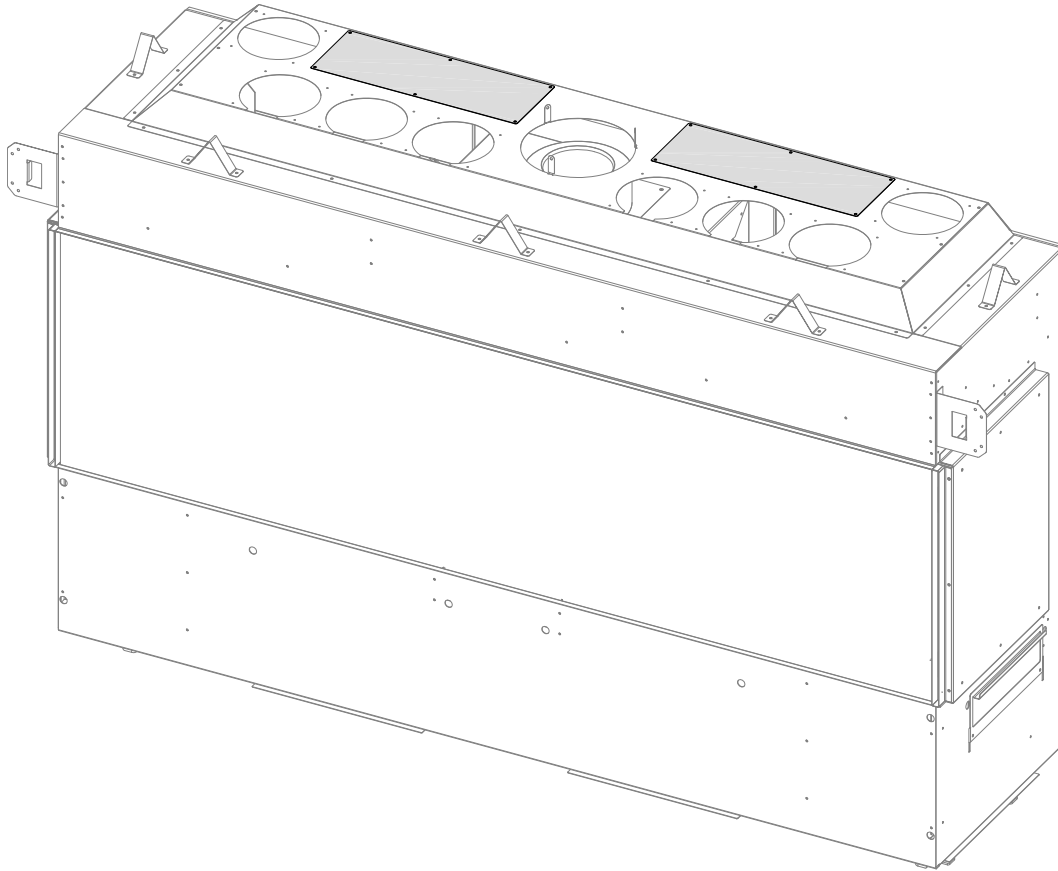

Figure 2.14 - Vented Cavity Cover Plate Location

2.4.4 Vented Cavity Openings - Front Of The Chamber

Shown below are the minimum requirements for the chamber air intake and heat release openings where the openings are on the front of the chamber only. The ceiling must be flush with the top of the vented cavity opening.

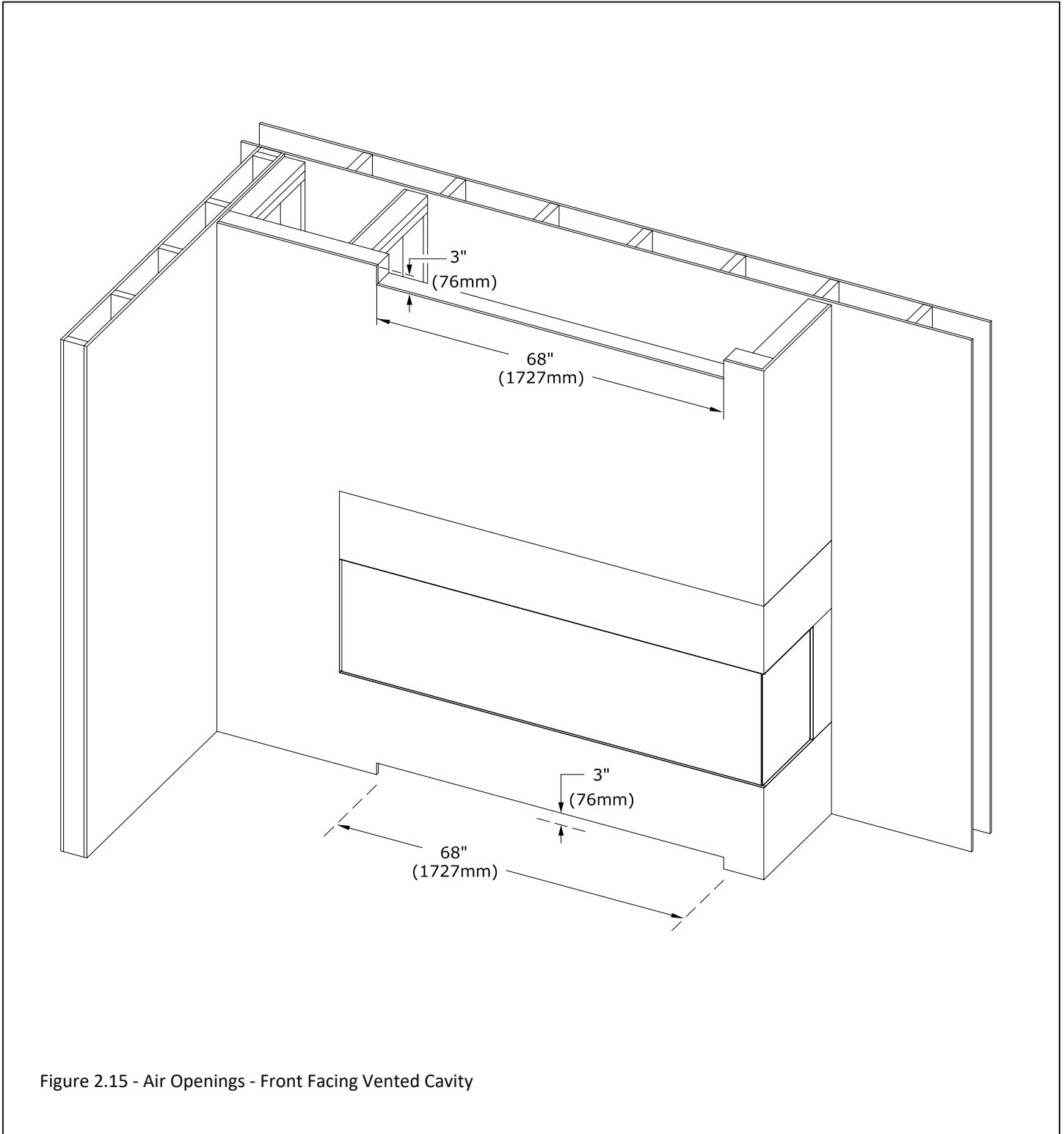
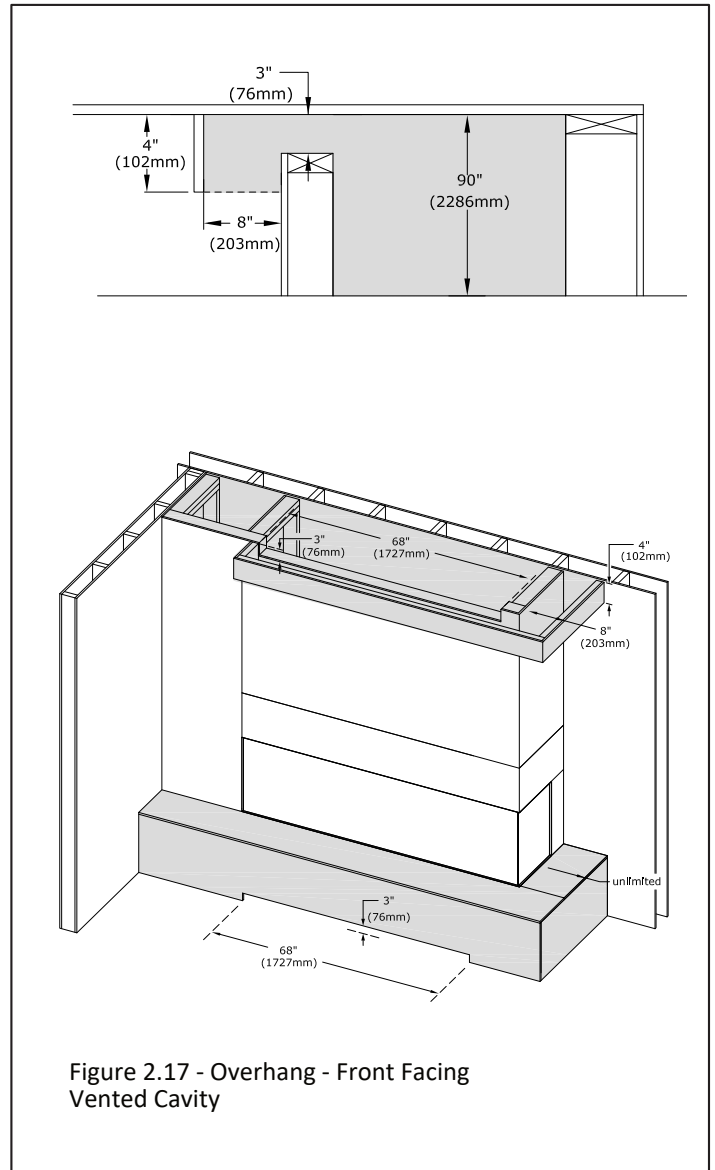
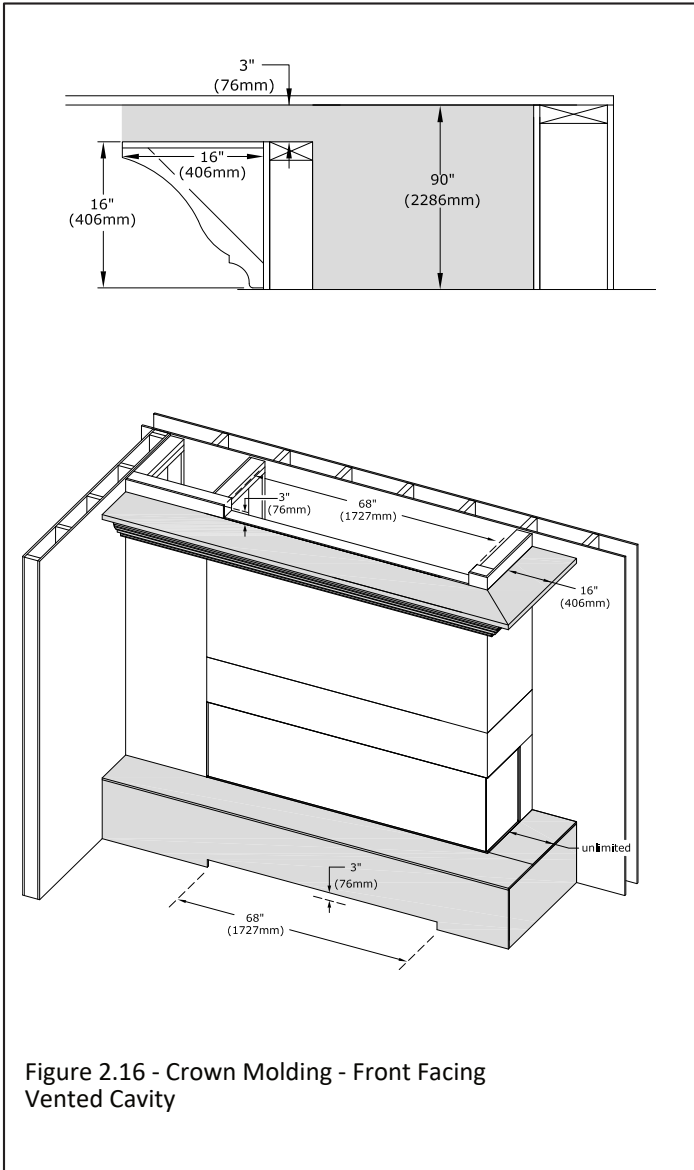

Figure 2.15 - Air Openings - Front Facing Vented Cavity

2.4.4 Vented Cavity Openings - Front Of The Chamber (continued)

The figures on this page show how you can visually conceal the heat release opening. This may provide a more desirable appearance. Figure 2.16 shows the use of crown molding. Figure 2.17 shows an overhang.



2.5 Hearth, Mantel, Front Chamber, and Side Chamber Projection for KZK Options

NOTE: A maximum of 16" (406mm) total projection is allowed between the mantel and chamber projection (regardless if it is combustible, non-combustible, or a combination). An example would be if you installed a 10" (254mm) front chamber projection then you would be allowed up to a 6" (152mm) mantel until you hit the limit of 16" (406mm).

2.5.1 Combustible Hearth and Mantel Requirements

WARNING: All minimum clearances to combustible material **MUST** be maintained.

- **Combustible Mantel Projections:** A maximum of a 16" (406mm) mantel can be installed flush at the side and top finishing edge. See Figure 2.18
- **Combustible Chamber Projections:** A maximum of a 16" (406mm) chamber projection can be installed flush at the side and top finishing edge of the fireplace. See Figure 2.19.
- **Combustible Mantel Leg:** A mantel leg can be installed at 0" (0mm) to the fireplace side finishing edge. Refer to Figure 2.20 which shows a combustible projection up to a max of 16" (407mm) on the fireplace side finishing edge.
- **Combustible Hearth:** Combustible hearth can have an unlimited projection. Hearth can be raised flush to the bottom finishing edge. See Figure 2.18.

2.5.2 Non-combustible Mantel and Chamber Projection Requirements

- **Non-combustible Mantel Projections:** A maximum of a 16" (406mm) non-combustible mantel projection is allowed to start at 0" (0mm) from the fireplace top finishing edge.
- **Non-combustible Chamber Projection:** A maximum of a 16" (406mm) non-combustible chamber projection can be installed flush at the front and side finishing edges of the fireplace

IMPORTANT: You are required to have the minimum non-combustible facing material along the front and sides of the fireplace before constructing the framing of the chamber projection. The non-combustible facing material prevents the combustible framing of the chamber projection from directly contacting the fireplace. See Section 2.5.3 for more information.

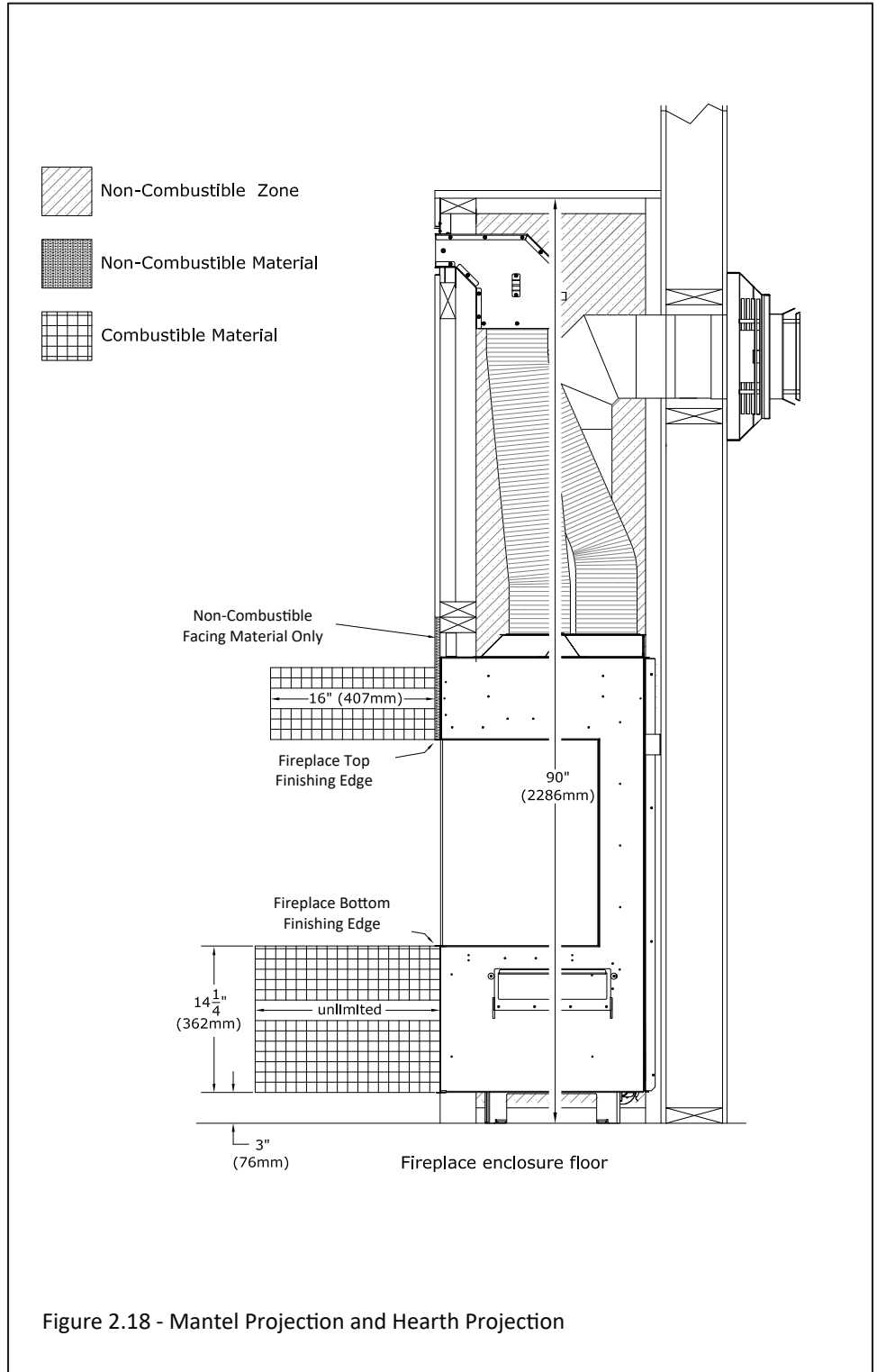

Figure 2.18 - Mantel Projection and Hearth Projection

2.5 Hearth, Mantel, Front Chamber, and Side Chamber Projection for KZK Options (continued)

Figure 2.19 shows the KZK installed in a 16" front chamber projection. The 16" non-combustible projection would also apply to any side chamber projection.

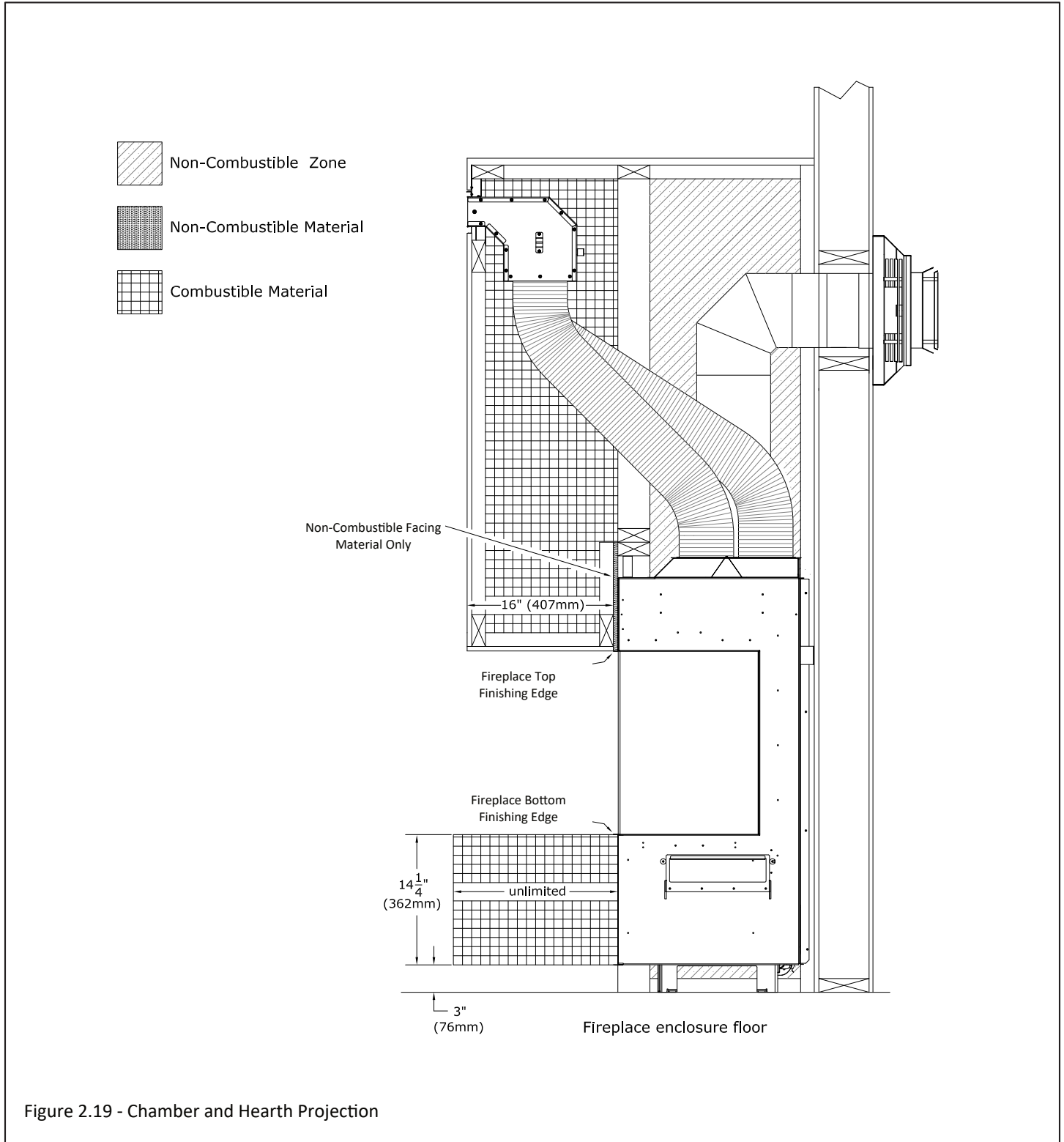

Figure 2.19 - Chamber and Hearth Projection

2.5 Hearth, Mantel, Front Chamber, and Side Chamber Projection for KZK Options (continued)

Figure 2.20 shows a fireplace with a front and side chamber projection with a hearth installed.

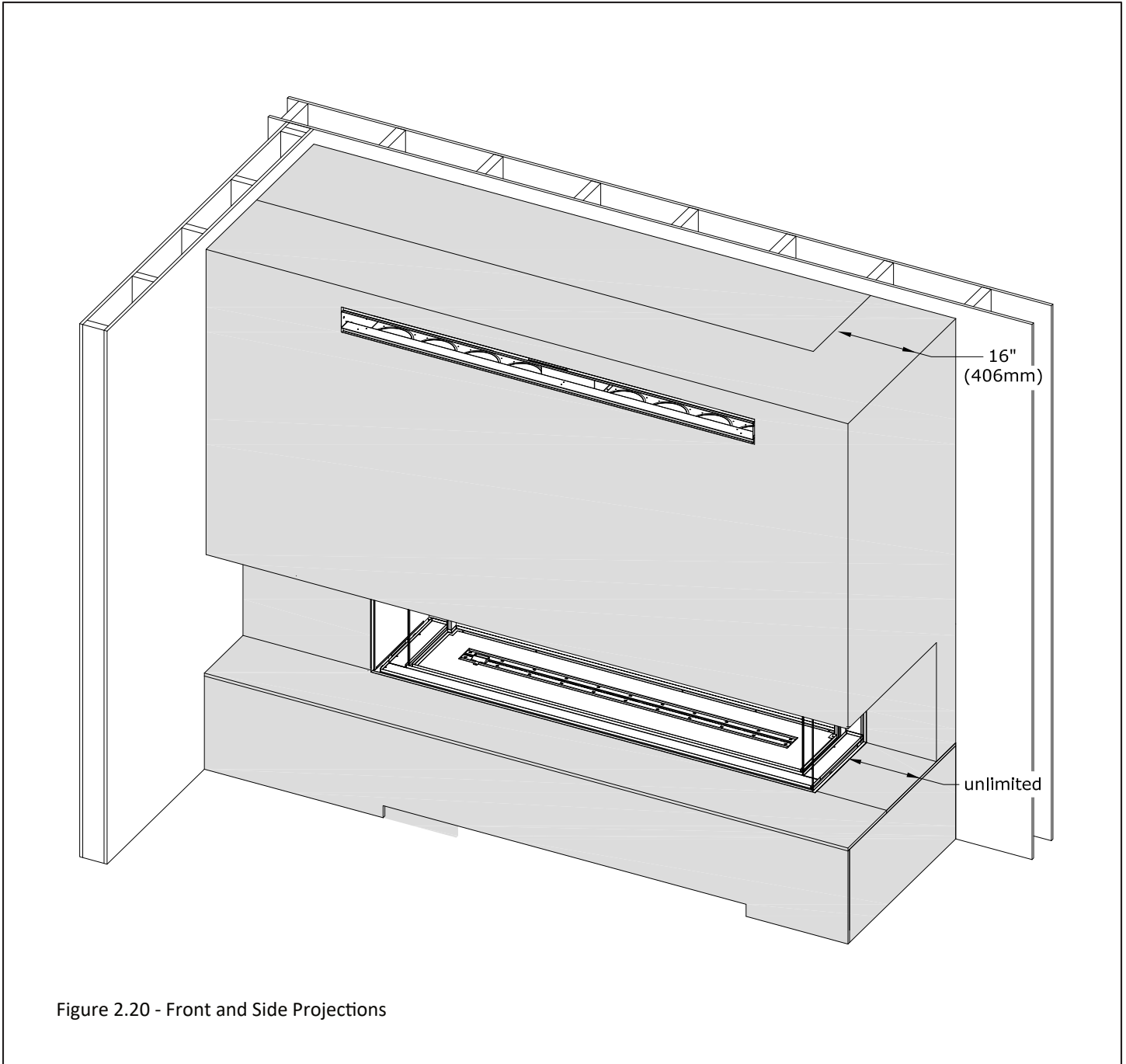

Figure 2.20 - Front and Side Projections

2.5.3 How to Construct a Chamber Projection with a KZK

This section is an overview of the steps in constructing a chamber projection when using a KZK. Figures 2.21 and 2.22 show this process. The fireplace chamber does NOT need to be sealed separately from the front projection. This is because the air will heat up and rise through the KZK air duct pipes and exit through the KZK plenum(s).

- Frame out the chamber above the fireplace. Install the required non-combustible facing material as required in Section 2.3.

NOTE: This non-combustible facing material is only required if you intend on using combustible framing for the projection. If you use non-combustible framing then it can come into direct contact with the fireplace (non-combustible facing material is not required).

- Next frame out the projection and install the KZK. Lastly install the facing material and finishing material.

IMPORTANT: Maintain ½" (13mm) clearance around the KZK air duct pipes to anything combustible.

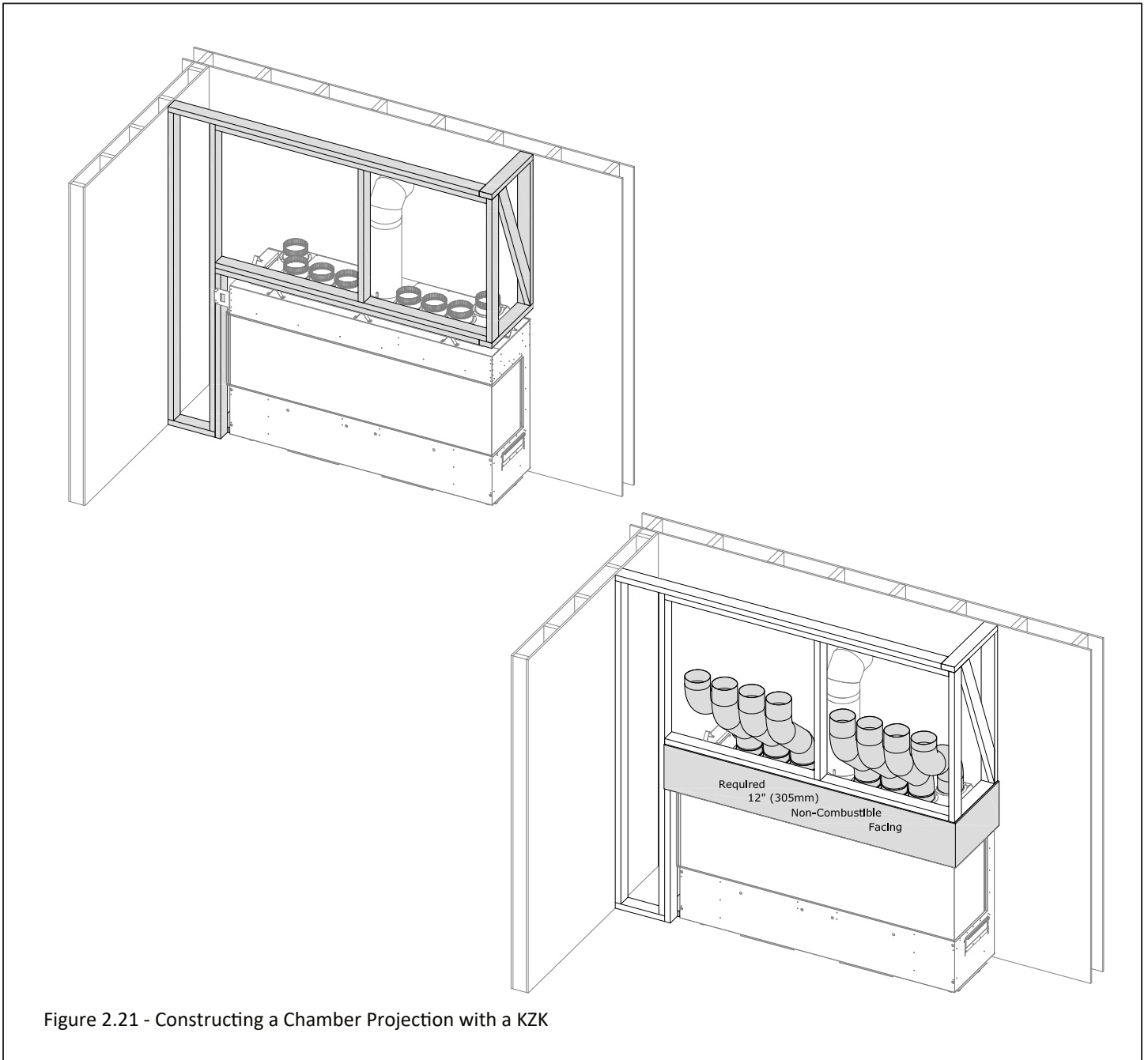

2.5.3 How to Construct a Chamber Projection with a KZK (continued)

IMPORTANT: Maintain 1/2" (13mm) clearance around the KZK air duct pipes to anything combustible.

- The top left image shows the start of the framing process. Ensure framing distances to fireplace finishing edges accommodate finishing material.
- The bottom right image shows the finished chamber and hearth projection.

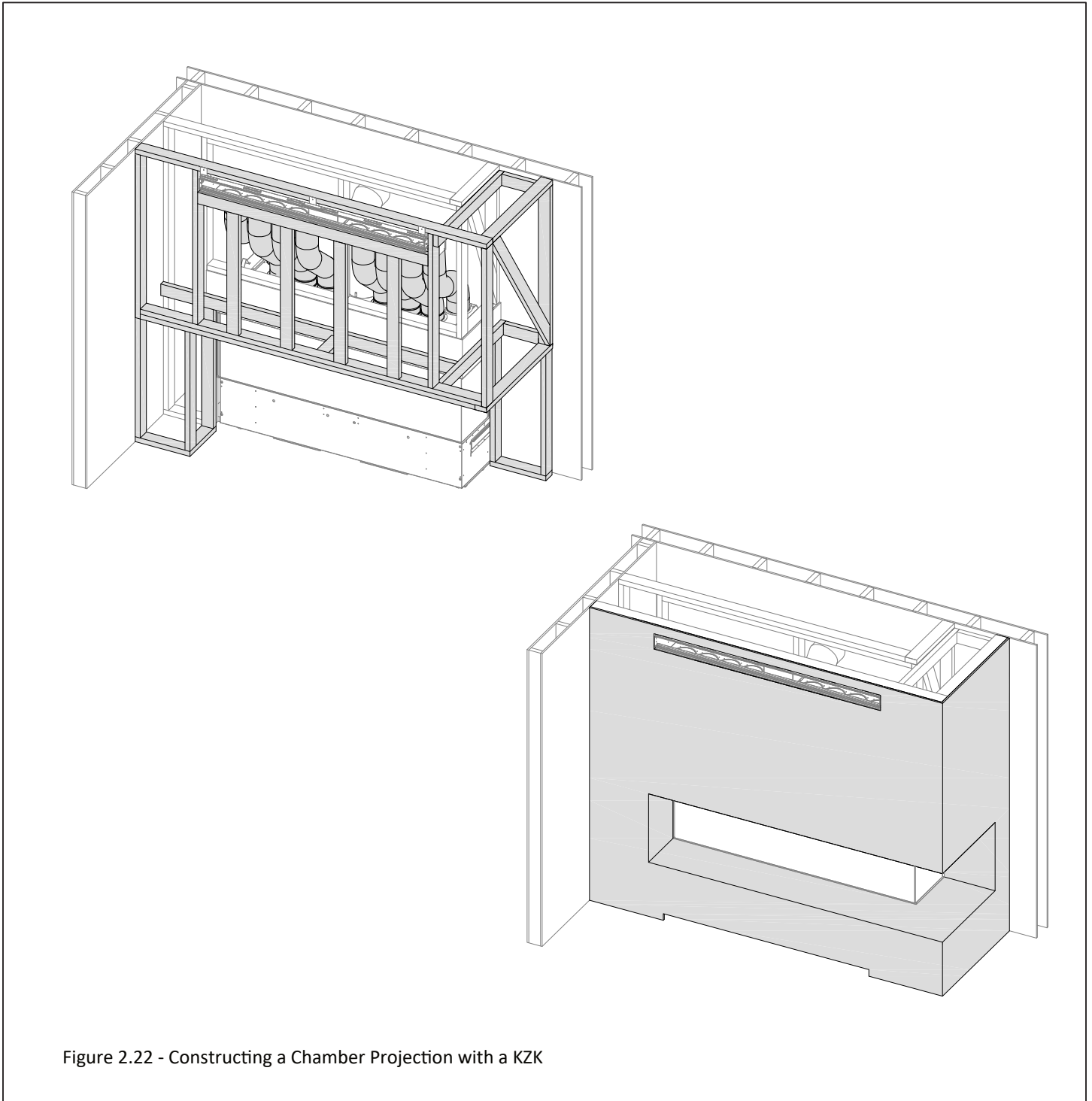

Figure 2.22 - Constructing a Chamber Projection with a KZK

2.6 Hearth, Mantel, Front Chamber, and Side Chamber Projection for Vented Cavity Options

NOTE: A maximum of 16" (406mm) total projection is allowed between the mantel and chamber projection (regardless if it is combustible, non-combustible, or a combination). An example would be if you installed a 10" (254mm) front chamber projection then you would be allowed up to a 6" (152mm) mantel until you hit the limit of 16" (406mm).

2.6.1 Combustible Hearth and Mantel Requirements

WARNING: All minimum clearances to combustible material **MUST** be maintained.

- **Combustible Mantel Projections:** A maximum of a 16" (406mm) mantel can be installed flush at the side and top finishing edge. See Figure 2.23.
- **Combustible Chamber Projections:** A maximum of a 16" (406mm) chamber projection can be installed flush at the side and top finishing edge of the fireplace. See Figure 2.24.
- **Combustible Mantel Leg:** A mantel leg can be installed at 0" (0mm) to the fireplace side finishing edge. Refer to Figure 2.25 which shows a combustible projection up to a max of 16" (407mm) on the fireplace side finishing edge.
- **Combustible Hearth:** Combustible hearth can have an unlimited projection. Hearth can be raised flush to the bottom finishing edge. See Figure 2.23.

2.6.2 Non-combustible Mantel and Chamber Projection Requirements

- **Non-combustible Mantel Projections:** A maximum of a 16" (406mm) non-combustible mantel projection is allowed to start at 0" (0mm) from the top fireplace top finishing edge.
- **Non-combustible Chamber Projection:** A maximum of a 16" (406mm) non-combustible chamber projection can be installed flush at the front and side finishing edges of the fireplace.

IMPORTANT: You are required to have the minimum non-combustible facing material along the front and sides of the fireplace before constructing the framing of the chamber projection. The non-combustible facing material prevents the combustible framing of the chamber projection from directly contacting the fireplace. See Section 2.6.3 for more information.

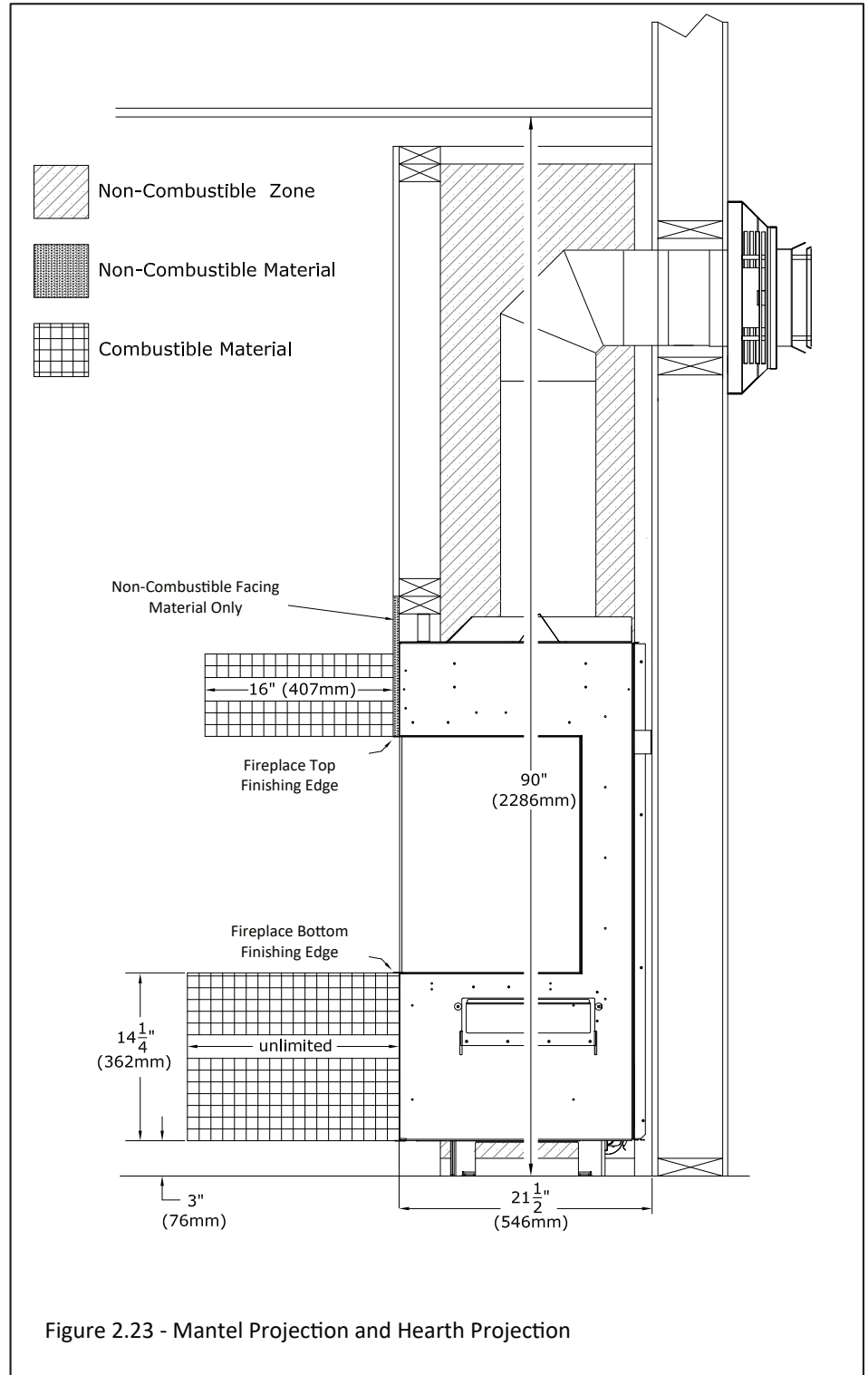

Figure 2.23 - Mantel Projection and Hearth Projection

2.6 Hearth, Mantel, Front Chamber Projection, and Side Chamber Projection for Vented Cavity Options (continued)

Figure 2.24 shows a 16" (406mm) combustible front chamber projection with a vented cavity. The air intake and heat release openings of the fireplace chamber must maintain their opening dimensions for the option you have chosen throughout the entire fireplace chamber and projection.

The hearth projection is unlimited.

IMPORTANT: It is required to install facing material on the fireplace chamber before constructing the chamber projection. This is required to ensure the convective cooling process of the fireplace functions correctly. See Section 2.6.3 on how to construct the chamber projection.

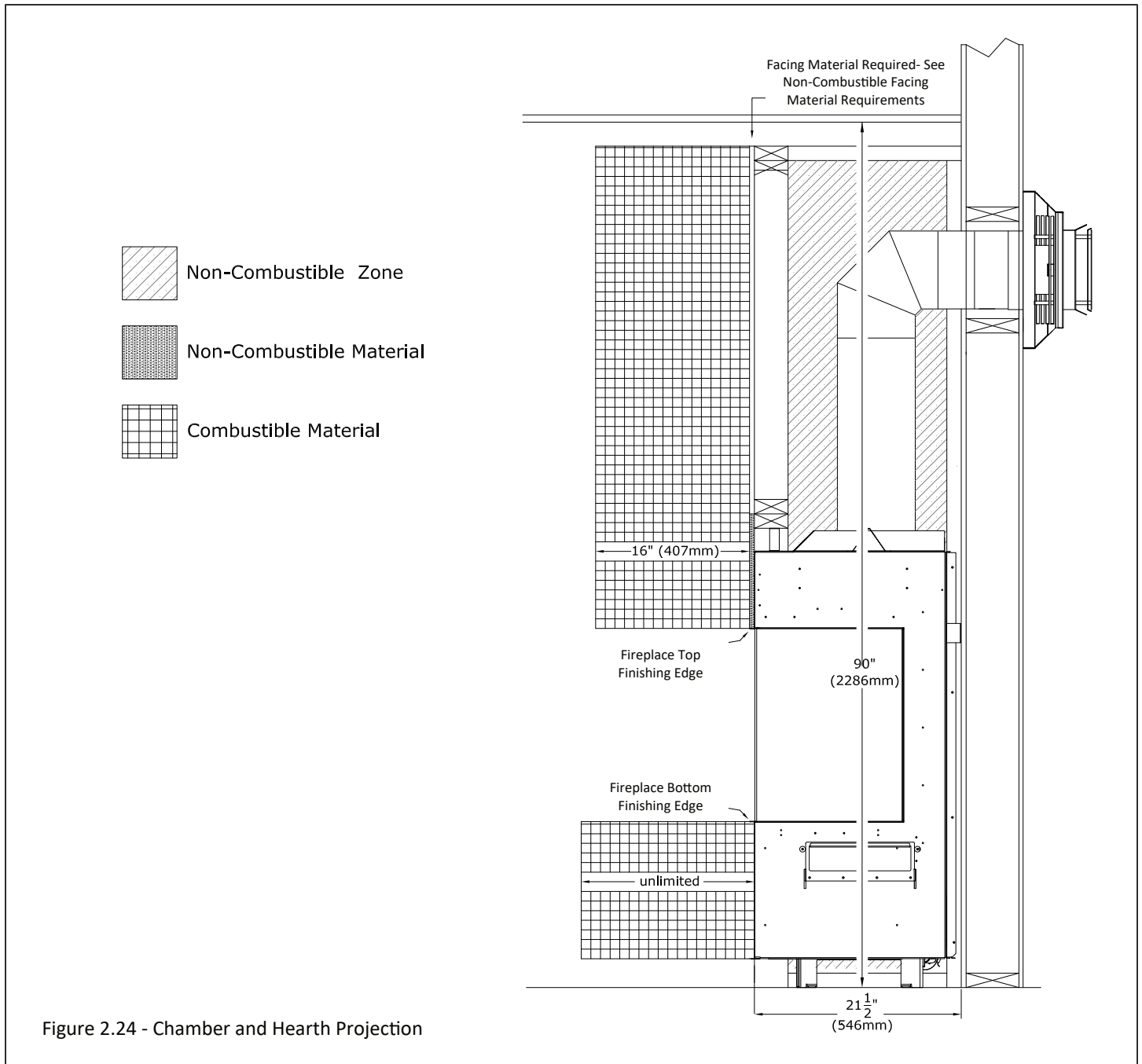

Figure 2.24 - Chamber and Hearth Projection

2.6 Hearth, Mantel, Front Chamber Projection, and Side Chamber Projection for Vented Cavity Options (continued)

Figure 2.25 shows a fireplace with a front and side chamber projection with a hearth installed.

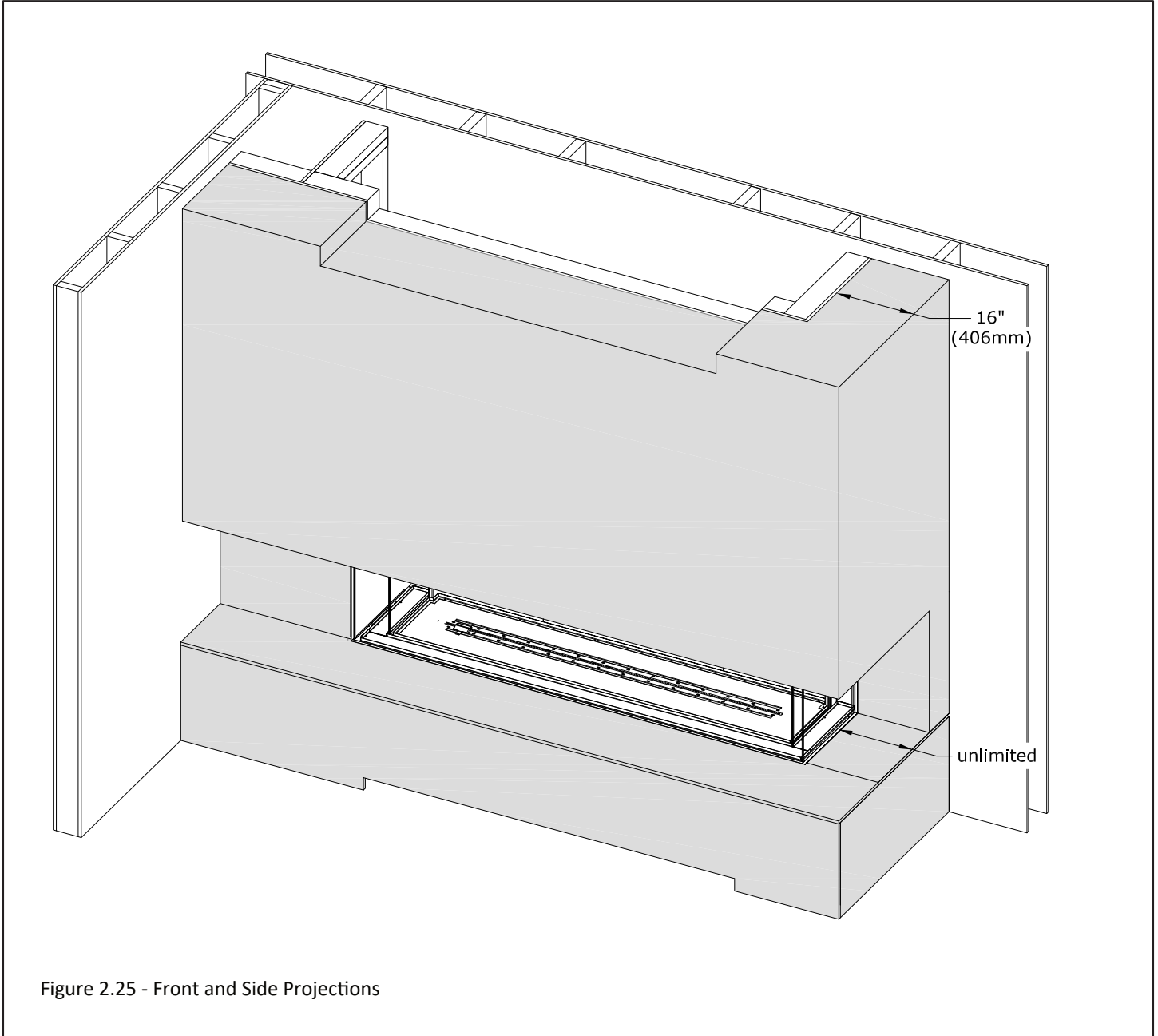

Figure 2.25 - Front and Side Projections

2.6.3 How to Construct a Chamber Projection with a Vented Cavity

This section is an overview of the steps in constructing a chamber projection when using a Vented Cavity. Figures 2.26 and 2.27 show a vented cavity that is open on all three sides of the chamber. You are required to construct the fireplace chamber and then install facing material first to ensure the convective cooling process of air entering the fireplace chamber at the bottom and discharging at the top of the chamber via the opening option you have chosen. The convective cooling process of the fireplace chamber is essential for proper function of the safety glass barrier and clearance to combustibles of the fireplace chamber.

- Frame out the chamber above the fireplace. Install all the facing material across the entire fireplace chamber which will seal the fireplace chamber from the projection. Pay attention to the required non-combustible facing material as required in Section 2.3.
- Next frame out the projection and ensure the vented cavity air opening maintains the required clearances. Lastly install the facing material and finishing material on the projection. The minimum dimensions of the air intake openings and heat release openings that you choose are required to be maintained in the initial fireplace chamber and throughout the projection.

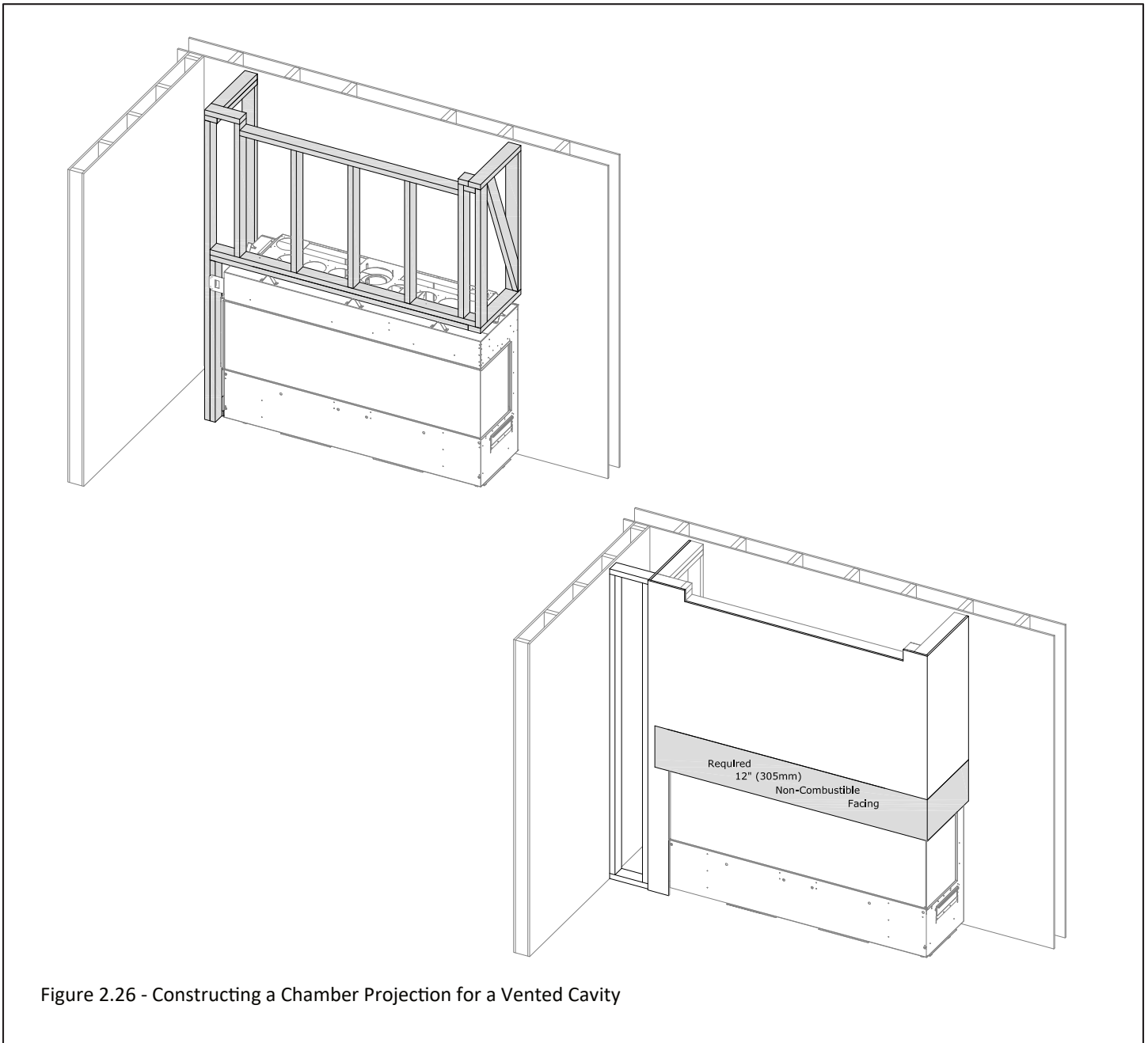

Figure 2.26 - Constructing a Chamber Projection for a Vented Cavity

2.6.3 How to Construct a Chamber Projection with a Vented Cavity (continued)

- The top left image shows the start of the framing process. Ensure framing distances to fireplace finishing edges accommodate finishing material.
- The bottom right image shows the finished chamber and hearth projection.

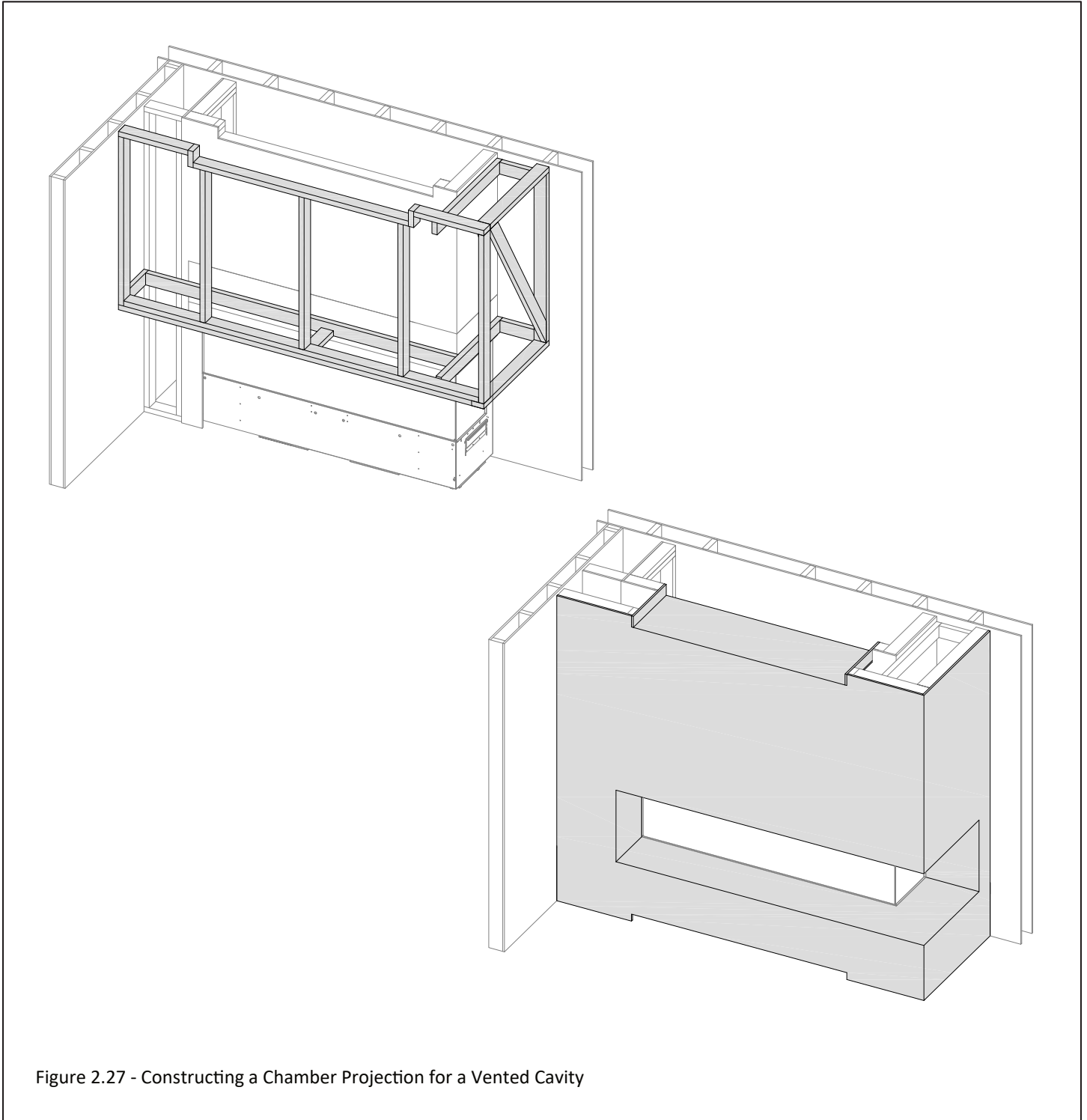

Figure 2.27 - Constructing a Chamber Projection for a Vented Cavity

2.7 Clearance to a Sidewall

The sidewall clearance is taken from the fireplace side finishing edge to the sidewall. The minimum clearance of 18" (457mm) applies to all Vented Cavity and KZK options.

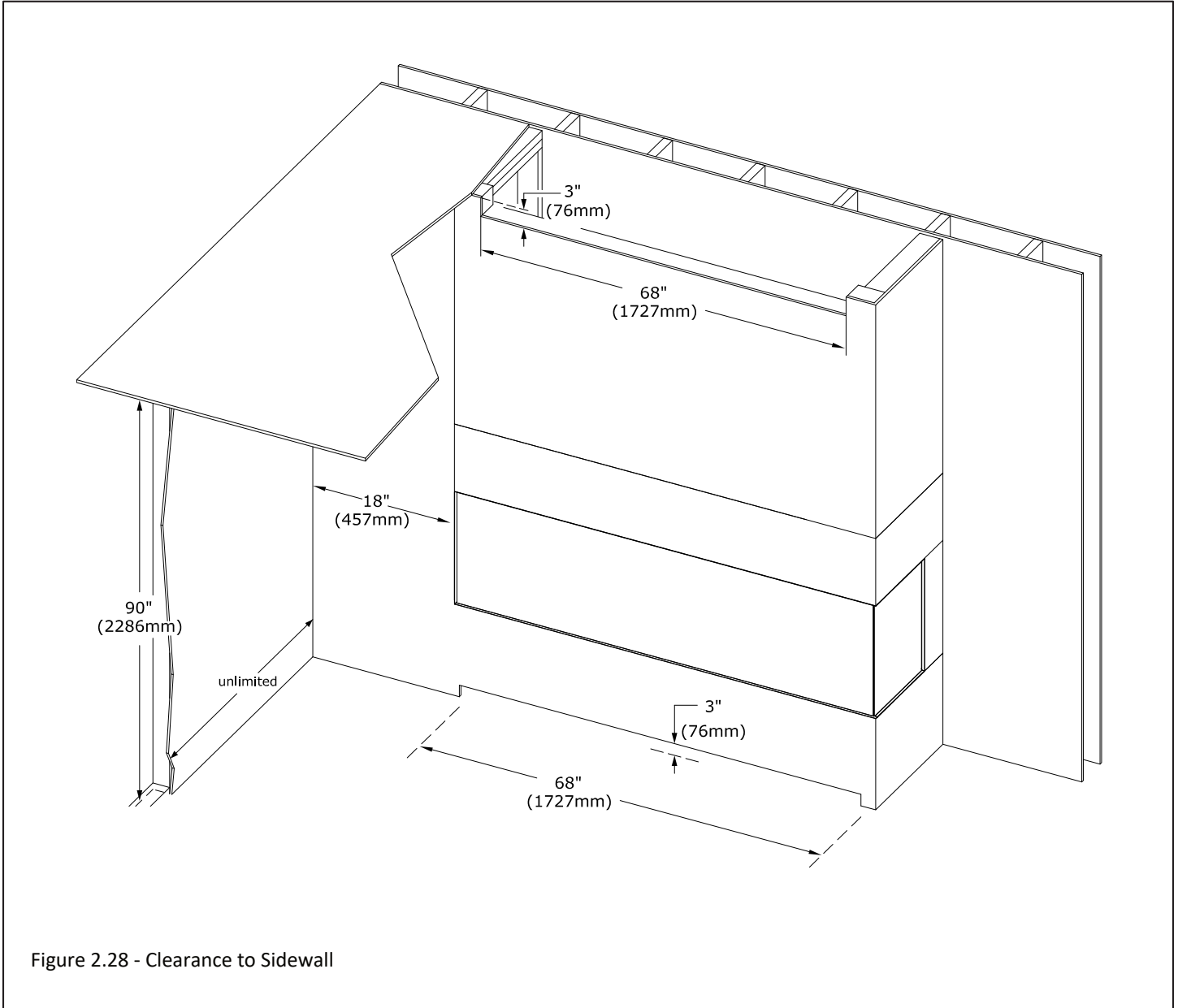

Figure 2.28 - Clearance to Sidewall

3.0 Three-Sided (Bay) Installation

The information provided in this section will cover topics related to installing this fireplace in its 3-sided configuration. The topics include: framing, facing material, finishing material, cooling the fireplace chamber, and chamber clearances.

3.1 Framing

Note: Unless otherwise noted all clearances / images in this manual are based off of nominal 2" x 4" framing being used.

IMPORTANT: The framing above the fireplace must be self supporting in all installation scenarios. The fireplace is not load-bearing.

WARNING: Provide adequate clearances around air openings into the combustion chamber. Provide adequate clearance in front of the fireplace for safety glass barrier removal, component access, gas line installation, service access, etc.

CAUTION: Cold air transfer area. The surround fireplace chase must comply with all clearances as outlined in this manual, and be constructed in compliance with local building codes. Outside walls should be insulated to prevent cold air from entering room.

- Floor protection in front of the fireplace is not required. Combustible material may be used if installing a hearth extension. Consider the thickness of the hearth extension finishing material if building a fireplace platform. The hearth may be flush with the bottom finishing edge of the fireplace.
- The bottom of the fireplace must be placed directly on a wood or non-combustible surface (not linoleum or carpet). If this appliance is to be installed directly on carpeting, tile, or other combustible material other than wood flooring, this appliance shall be installed on a metal or wood panel extending the full width and depth of the appliance.

IMPORTANT: To cool the fireplace chamber correctly take important consideration when planning out the framing for this fireplace. Look at the different options on how to cool the chamber that are outlined in Section 3.4. You must choose one of the KZK (Komfort Zone Kit) or Vented Cavity options. The framing will have to accommodate one of these chamber cooling options.

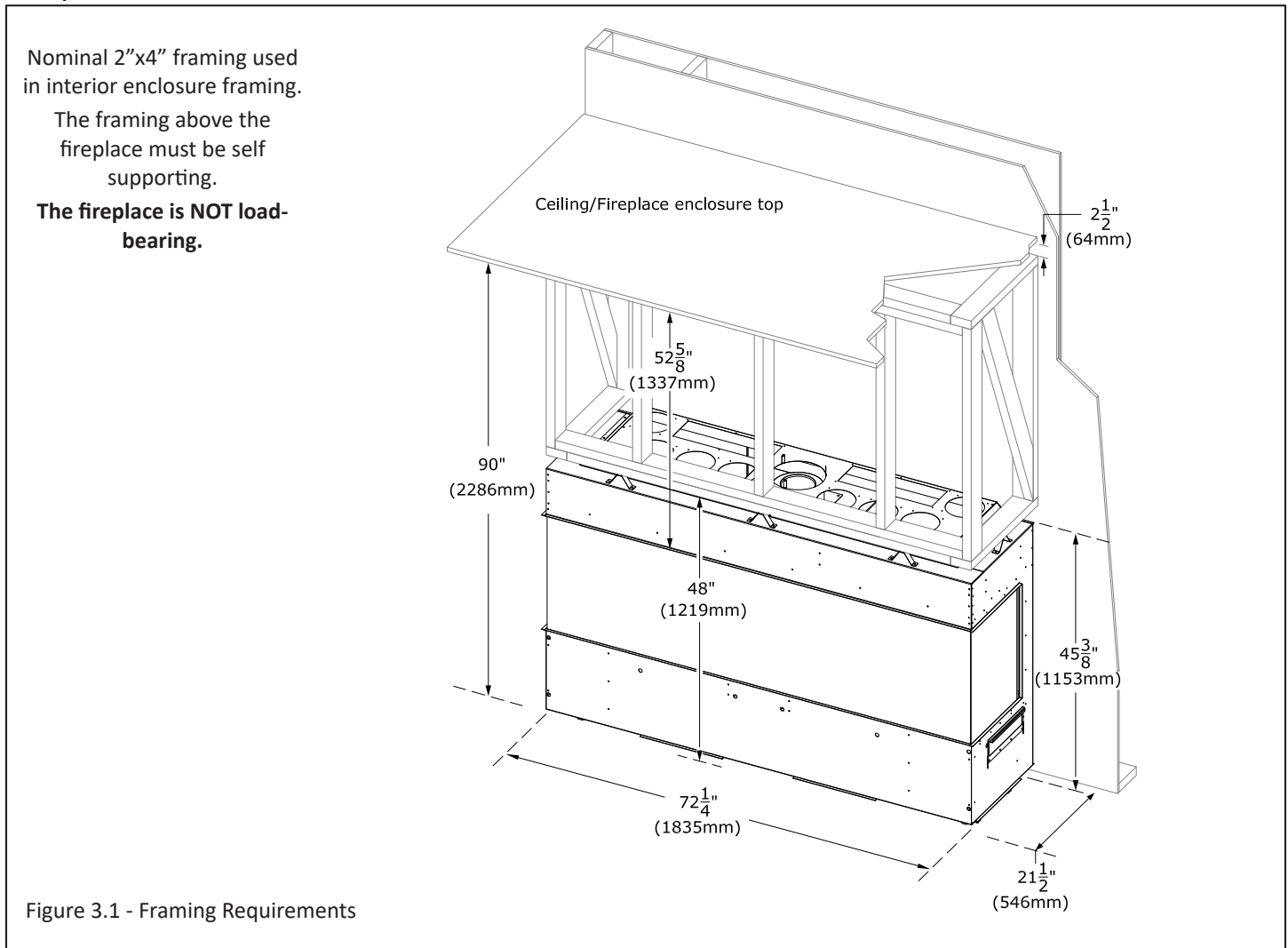

3.2 Recessed Fireplace Framing

WARNING: All clearances to venting must be maintained.

- It may be desirable to recess the fireplace into a false wall so the finishing material is next to the side glass.
- It is necessary to accommodate the thickness of the facing and finishing material when determining the framing.
- The measurement from the back of the chamber (fireplace back stand-off) to the rear side finishing edge is 5-7/8" (149mm), which corresponds to Dimension A, shown in Figure 3.2.
 - Example: If your facing material and finishing material comes out to 1" (25mm) then your framing would be 4-7/8" (124mm) from the back of the chamber. Your finishing material would tuck behind the rear side finishing edge.
- In Figure 3.2 dimension A is the recessed framed depth of the false wall.
- **Only a front KZK (Komfort Zone Kit) or Front Vented Cavity is allowed when installing the fireplace in a recessed installation option.**

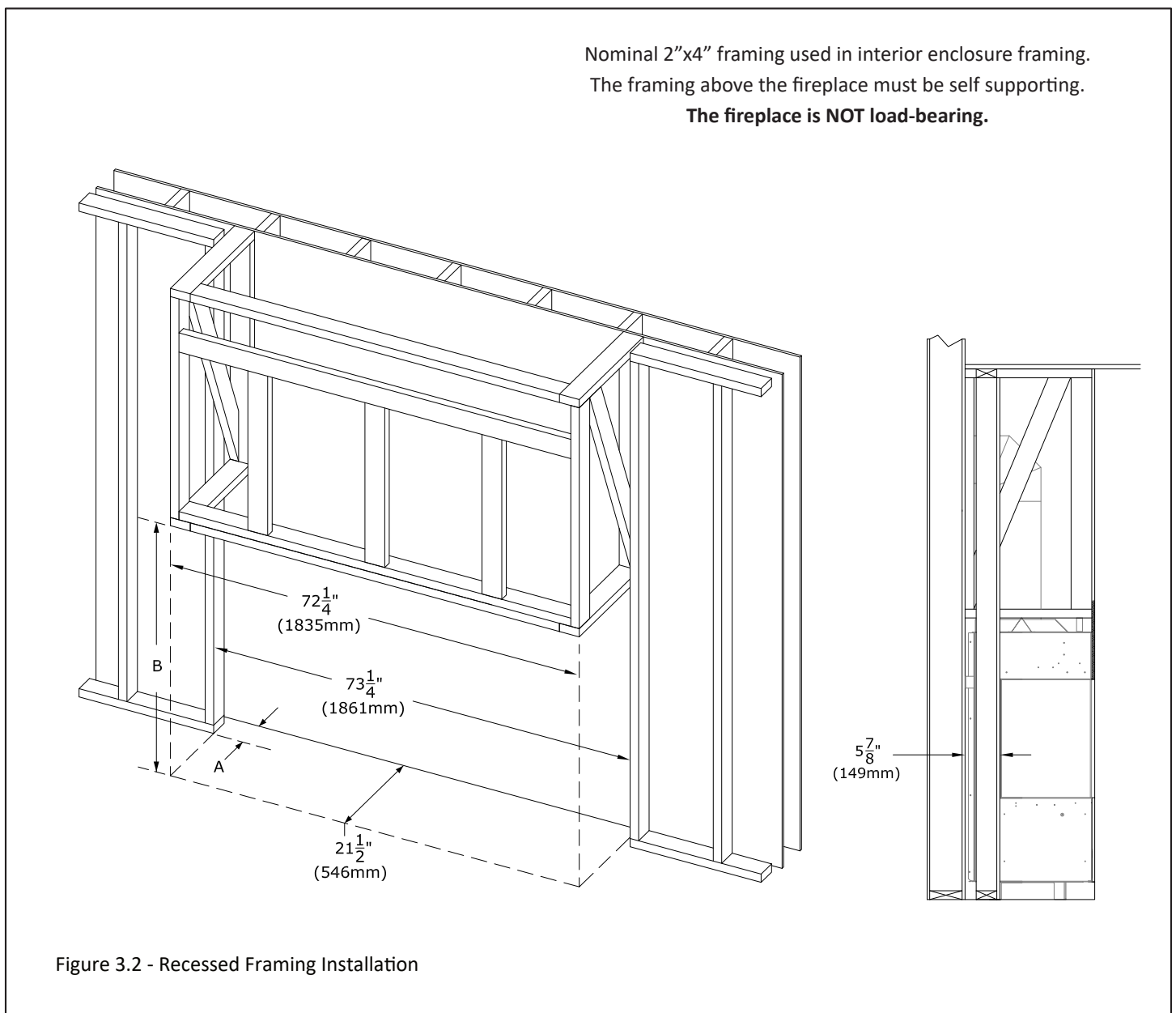

3.2 Recessed Fireplace Framing (continued)

- Figure 3.3 shows how to face the fireplace chamber when installing the fireplace in a recessed application. You are required to first face the fireplace chamber then build the walls off to the sides.
- Follow all non-combustible facing requirements in Section 3.3 before building the walls off to the sides. The required non-combustible material prevents the combustible framing of the recessed wall from touching the fireplace.

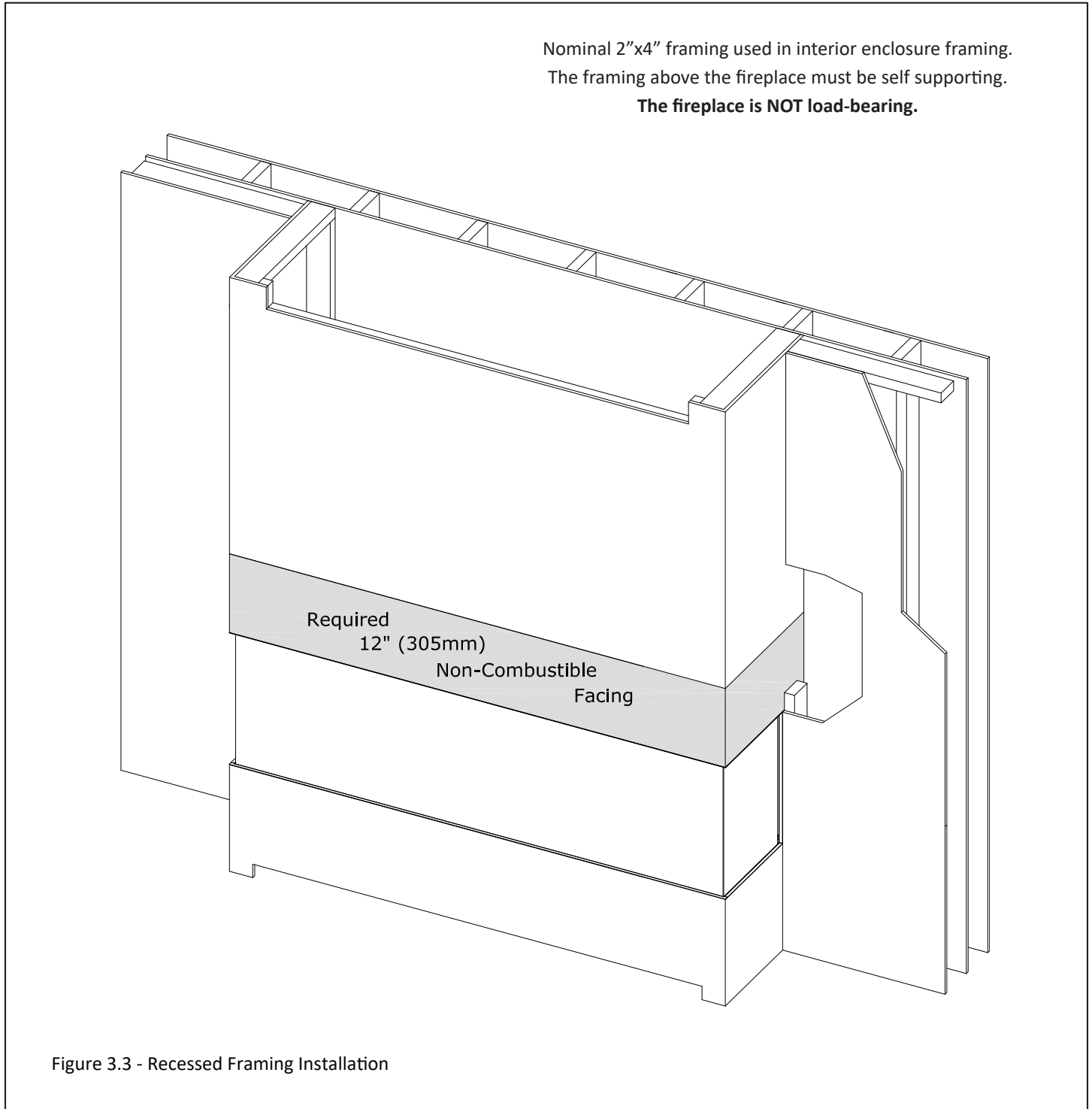

3.3 Facing Requirements

The information in this section shows the minimum non-combustible facing requirements. These requirements apply for vented cavity or KZK installations. Figure 3.4 shows the minimum 12" (305mm) non-combustible facing material above the fireplace top finishing edge.

Take special consideration where you attach the facing material to the fireplace as there are no-screw zones on this fireplace. The image below shows three no screw zones for the facing and finishing material. There is a 1" (25mm) zone below the fireplace bottom finishing edge and a 2-3/8" (60mm) zone above the fireplace top finishing edge. The third location is 45-1/2" (1156mm) x 4-1/4" (108mm) centered above the air intake opening.

Make sure the screws only penetrate up to 1/2" (13mm) into the allowed areas of the fireplace. Take consideration of this when choosing screw length based on your facing material thickness.

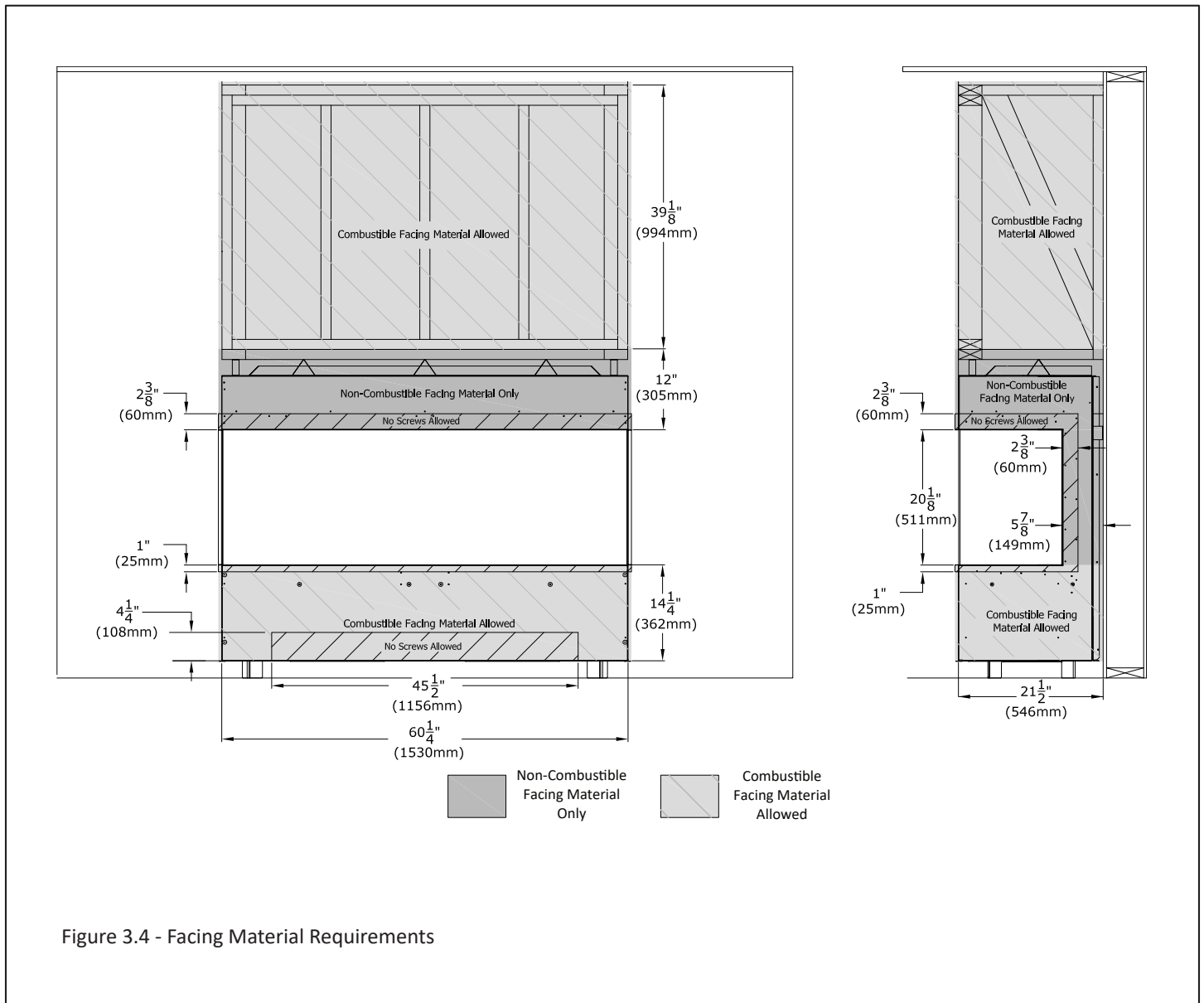

Figure 3.4 - Facing Material Requirements

3.4 Requirements to Cool the Fireplace Chamber and Safety Glass Barriers

IMPORTANT: This fireplace requires that the fireplace chamber has airflow to cool it. You must choose one of the options in this section to cool the fireplace chamber. You must select and follow the requirements of one of the options in this section that use an air intake opening with a vented cavity heat release opening or KZK heat release.

The air intake opening supplies the necessary room air to cool the chamber and safety glass barrier. The Vented Cavity or KZK heat release opening discharges the warm air from the chamber and fireplace. This airflow is separate from the air that is used in the vent system and combustion process.

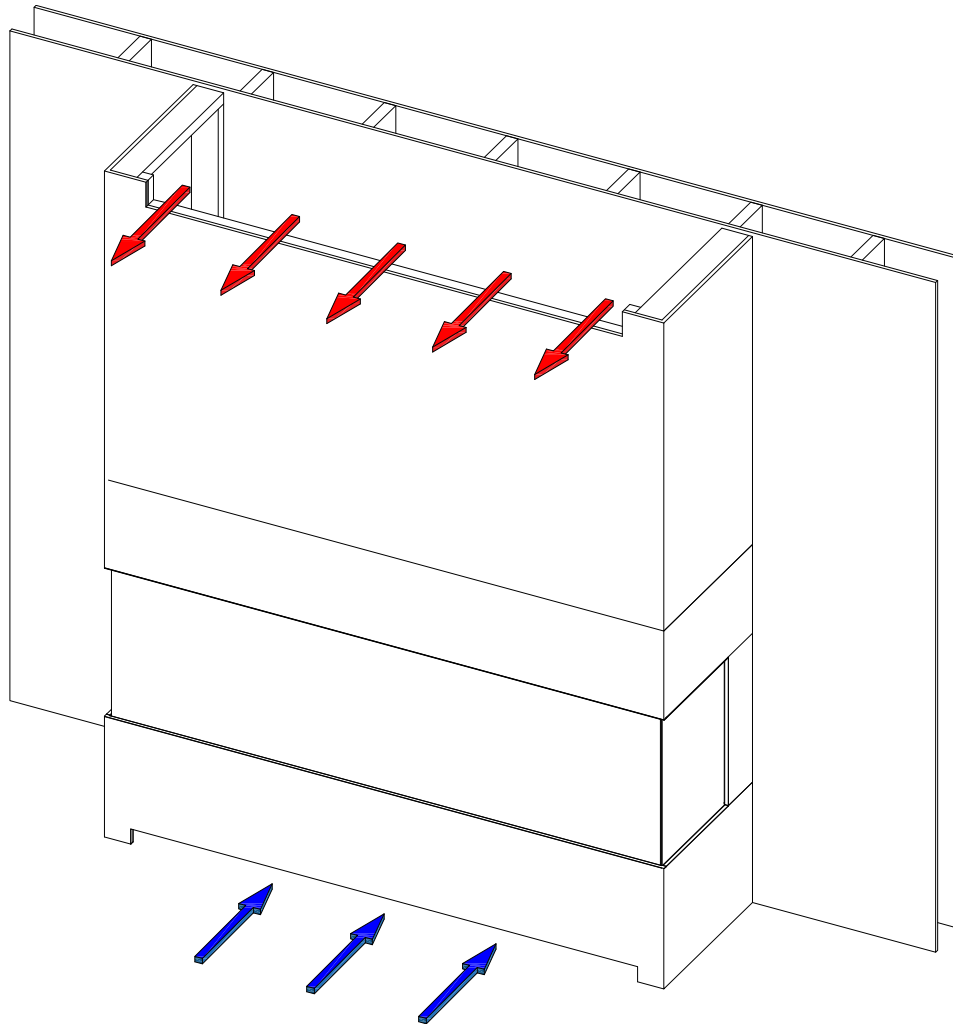

Figure 3.5 -Cooling the Fireplace Chamber and Safety Glass Barriers

3.4.1 KZK Installation Overview

Note: the KZK collars cannot be installed on the fireplace when sliding the fireplace into the framed opening. Install after installing into the framed opening.

1. Slide the fireplace into the framed opening. Ensure the two rectangle rear cover plates stay installed on the fireplace. .
2. Use the (32) provided sheet metal screws to install the (8) KZK collars on the top of the fireplace.
3. Frame the rough opening of the KZK plenum(s). Refer to all pages of this manual to ensure all framing and finishing materials are considered.
4. Install the plenum(s) into the rough framed opening to maintain minimum clearances to combustibles. If you are installing the front KZK we recommend using the supplied plenum support brackets to help support the weight of the plenum and air duct pipes. Ensure the plenum(s) are level (All KZK Options) and their outlet(s) are not distorted. Additional metal strapping may be needed to support the weight of the air duct pipes depending on the height of installation.
5. Attach the air duct pipes from all (8) plenum vent collars to all (8) fireplace vent collars. An upward slope must be maintained in horizontal section of air duct pipe for proper convection.
6. Install the KZK discharge trim or KZK grilles provided with the kit using the provided screws. If desired, the discharge trim or grilles may be painted using high temperature paint (250F or 121°C). Continue with fireplace installation.

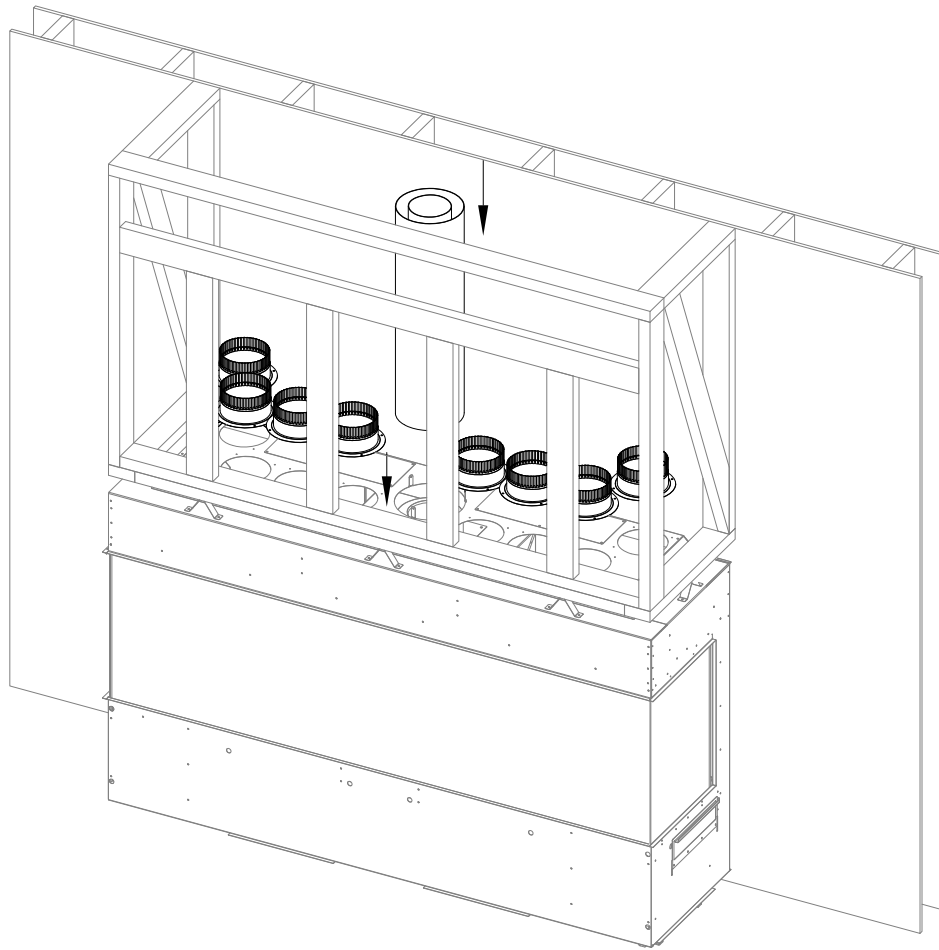

Figure 3.6 - KZK Collar Installation

3.4.2 Front KZK - Part # KZK-068

This section outlines the requirements for using the front KZK option to cool the fireplace chamber. This option requires the use of an air intake opening in the fireplace chamber and the installation of the front KZK.

Kit Contents

ALL kit contents must be installed.

- (1) 68" plenum kit: KZK-068
- (1) plenum discharge trim: KZK-068DT
- (2) plenum support brackets
- (16) 6" collars - (8) attach to the bottom of the plenum; (8) attach to the top of the fireplace.

Additional Required Items

- (2) KZK-410-6 kits (sold separately) are used for a vent run up to 10' (3m). If you are mounting the plenum above the fire-place 10' (3m) or less, use (2) KZK-410-6 kits.

Optional Items

If you are mounting the plenum above the fireplace between 10' (3m) to 20' (6.1m), you will need a total of (4) KZK-410-6 kits and (2) #KZK-CPL6 coupler kits. The (2) KZK-CPL6 coupler kits (sold separately) include the 6" couplers that connect (4) KZK-410-6 kits together.

Plenum Placement

- **IMPORTANT:** The air duct pipes cannot run horizontally without a vertical rise.
- **IMPORTANT:** The 1/2" (13mm) clearance around the air duct pipes must be maintained.
- Use (2) #KZK-410-6 (or UL181 Class 0 Air Duct piping) to connect the plenum to the unit.
- Hussong Mfg. Co., Inc. requires pipes to be listed as UL181 Class 0 Air Duct to connect the plenum to the unit.
- Maximum Vent Run: 20' (6.10m)

(8) - 10' x 6" (aluminum flex) listed to UL-181 Class 0 Air Duct (sold separately)

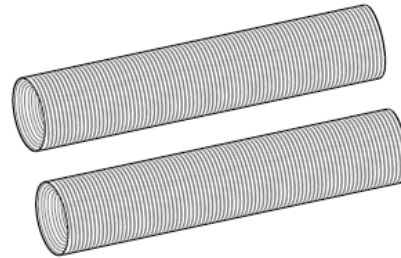

Figure 3.7 - #KZK-410-6 - QTY of 2 kits

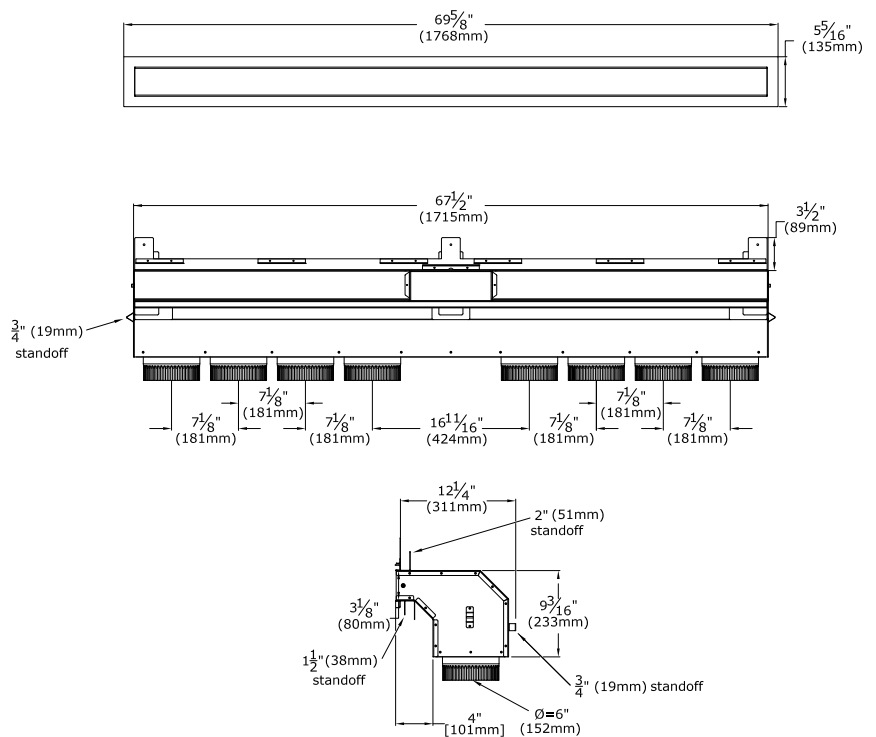

Figure 3.8 - KZK-068 Overview

3.4.2 Front KZK (continued)

Below is the framing information for the front KZK. Figure 3.9 shows the framed opening for the KZK plenum. Figure 3.10 shows the framing information.

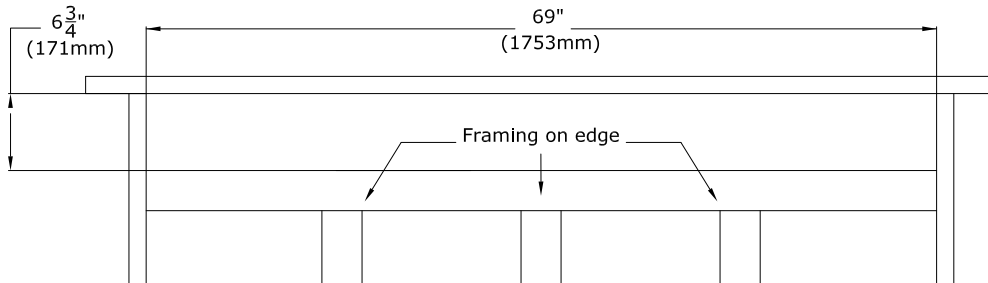

Figure 3.9 - Front KZK - Plenum Framed Opening

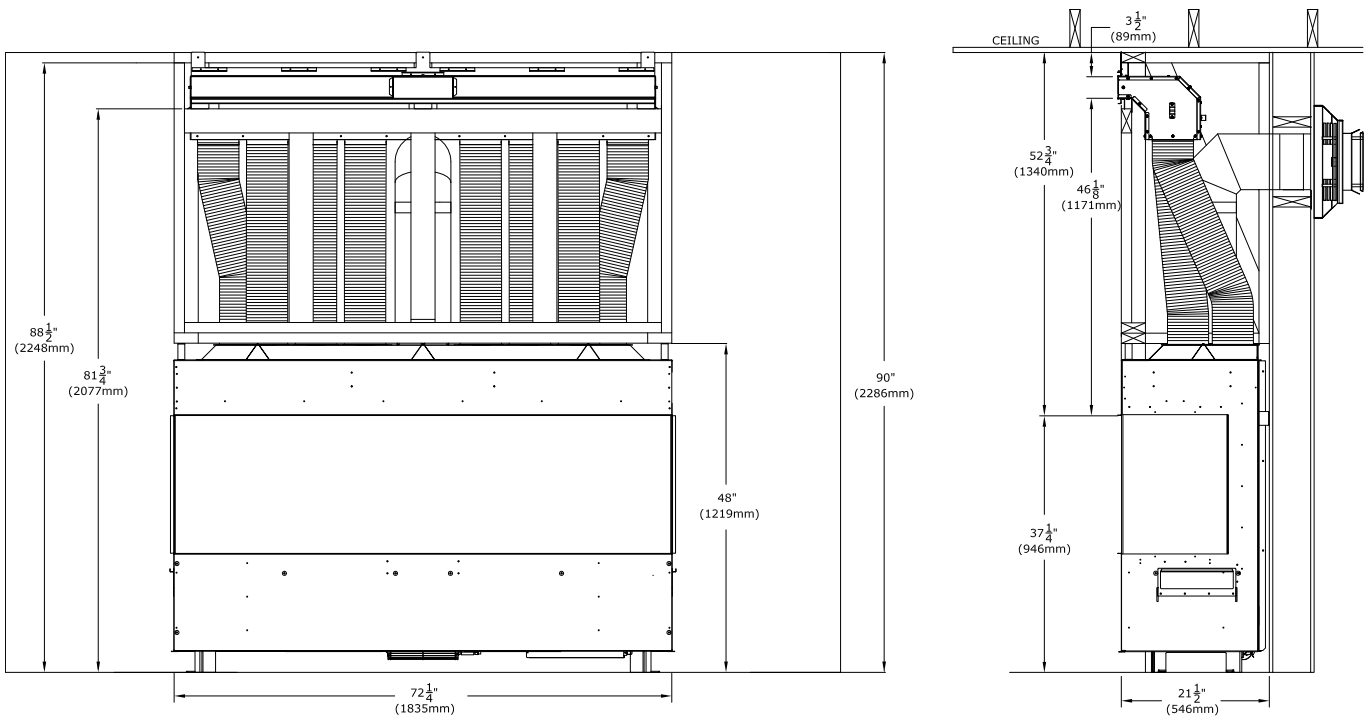

Figure 3.10 - Minimum Chamber Height Plenum Framing

3.4.2 Front KZK (continued)

Figure 3.11 shows the minimum air intake opening that is required for the front KZK installation.

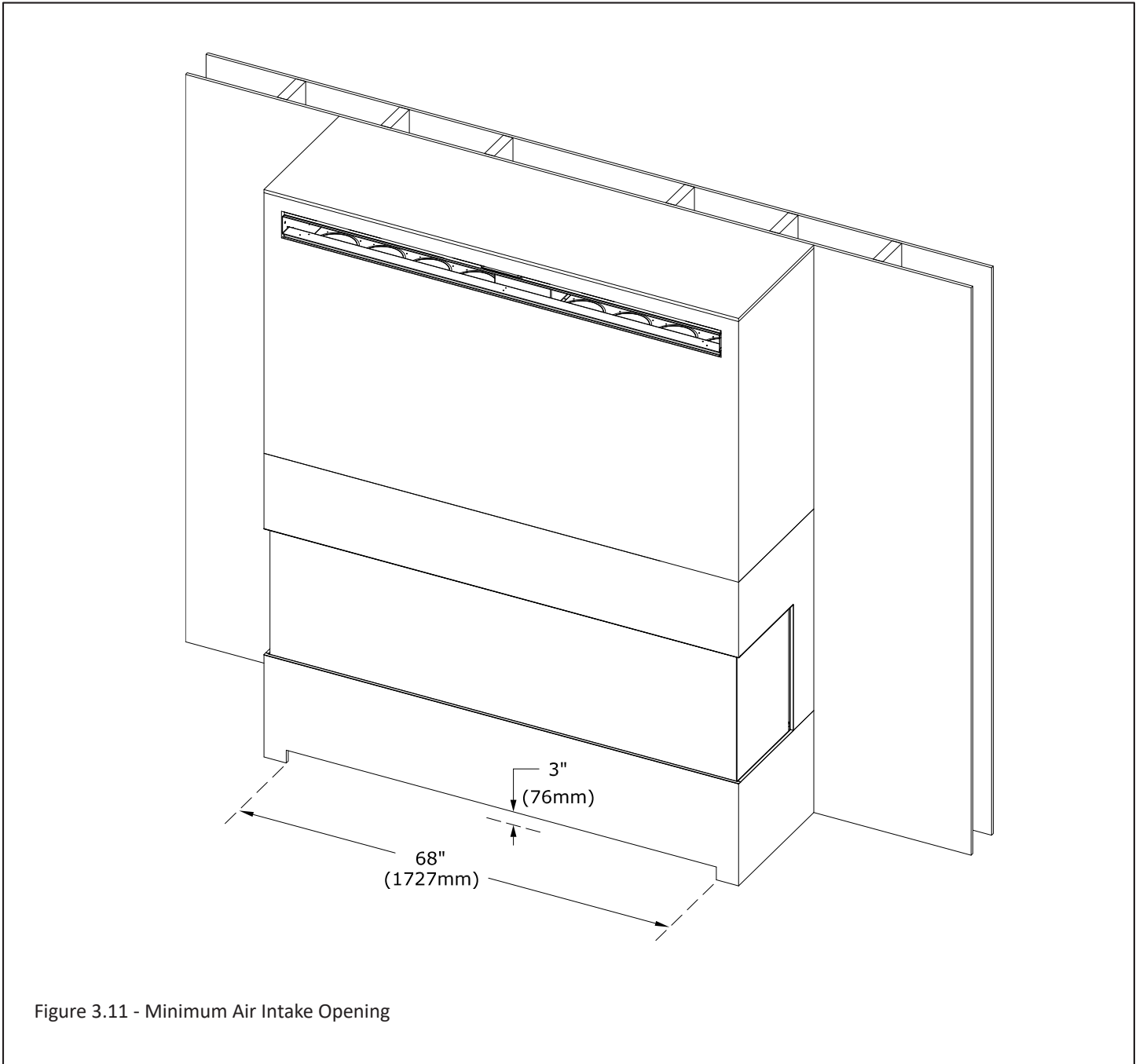

Figure 3.11 - Minimum Air Intake Opening

3.4.2 Front KZK (continued)

Shown below in Figure 3.12 are options on how you can finish around the front KZK plenum opening.

- The left image shows combustible facing material such as drywall finished up to the standoffs around the opening of the plenum. Install the KZK discharge trim to cover the edge of the finishing material.
- The middle image shows the allowed 1" thick additional finishing material such as shiplap. This material must stop at the edge of the discharge trim.
- The right image shows non-combustible finishing material such as tile that is finished up to the opening of the plenum.

Shown below in Figure 3.13 are options on how you can finish up to finishing edge of the air intake opening. Ensure the 3" (76mm) air intake opening is always maintained throughout all the facing and finishing material.

- The left image shows the 1/2" (13mm) combustible facing material butting up against the edge at the fireplace bottom.
- The middle image shows the allowed 1" (25mm) thick additional combustible finishing material such as shiplap.
- The right image shows non-combustible finishing material such as tile or stone.

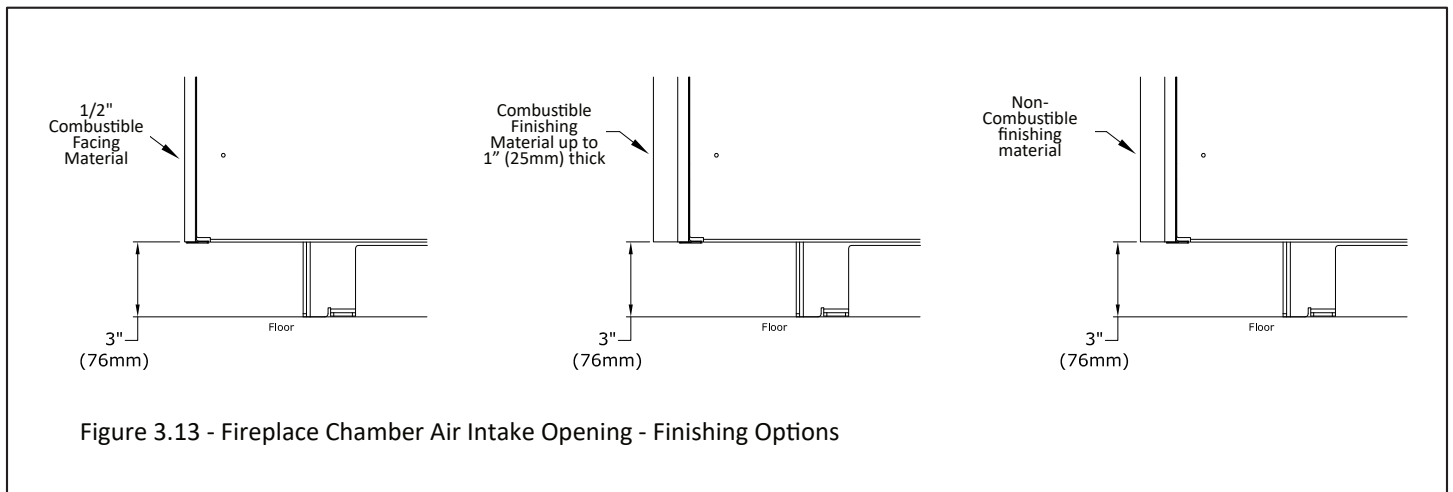
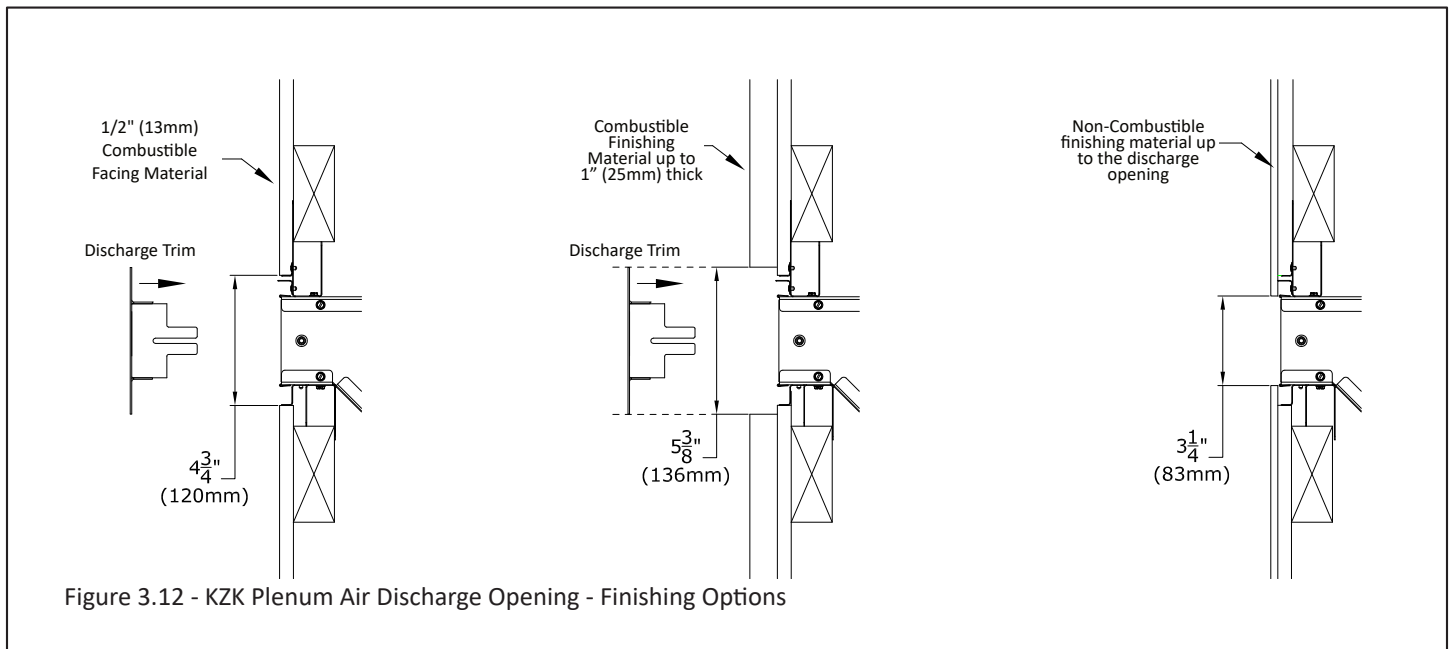

3.4.3 Side KZK - Part #KZK-1510B

This section outlines the requirements for using the side KZK option to cool the fireplace chamber. This option requires the use of an air intake opening in the fireplace chamber and the installation of the side KZK.

Kit Contents

ALL kit contents must be installed.

- (2) 15" plenums
- (2) plenum air grilles
- (16) 6" collars - (8) attach to the bottom of the plenums; (8) attach to the top of the fireplace.

Additional Required Items

- (2) KZK-410-6 kits (sold separately).
If the plenums vent run is 10' (3m) or less, use (2) KZK-410-6 kits.

Optional Items

If the plenums vent run is between 10' (3m) to 20' (6.1m), you will need a total of (4) KZK-410-6 kits and (2) #KZK-CPL6 coupler kits. The (2) KZK-CPL6 coupler kits (sold separately) include the 6" couplers that connect (4) KZK-410-6 kits together.

Plenum Placement

- **IMPORTANT:** The air duct pipes cannot run horizontally without a vertical rise.
- **IMPORTANT:** The 1/2" (13mm) clearance around the air duct pipes must be maintained.
- Use (2) #KZK-410-6 kits (or UL181 Class 0 Air Duct piping) to connect the plenums to the unit.
- Hussong Mfg. Co., Inc. requires air duct pipes to be listed as UL181 Class 0 Air Duct to connect the plenums to the unit.
- Maximum Vent Run: 20' (6.10m)

(8) - 10' x 6" (aluminum flex) listed to UL-181 Class 0 Air Duct (sold separately)

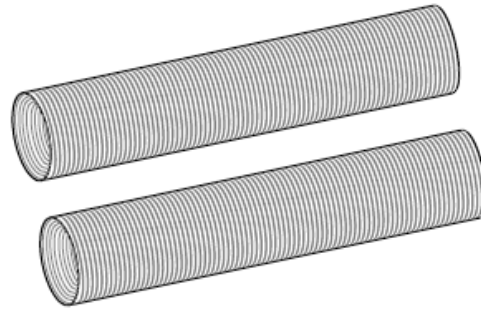

Figure 3.14 - #KZK-410-6 - QTY of 2 kits

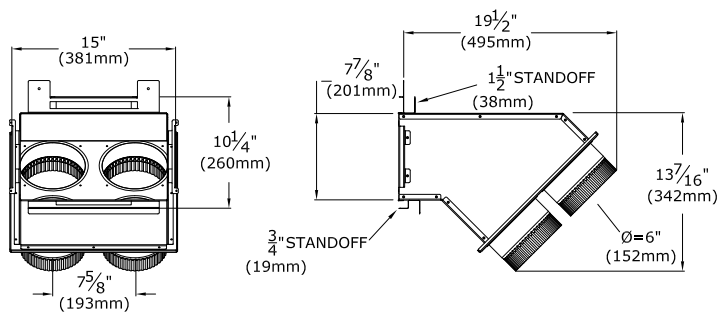
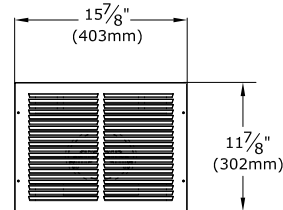

Figure 3.15 - KZK-1510B Overview

3.4.3 Side KZK Opening (continued)

Below is the framing information for the side KZK. Figure 3.16 shows the framed opening for each of the plenums in the side KZK.

IMPORTANT: In the drawing shown there is an arrow pointing to the dashed line along the back framing stud. You will have to notch 1/2" (13mm) out of the stud for the side KZK to fit.

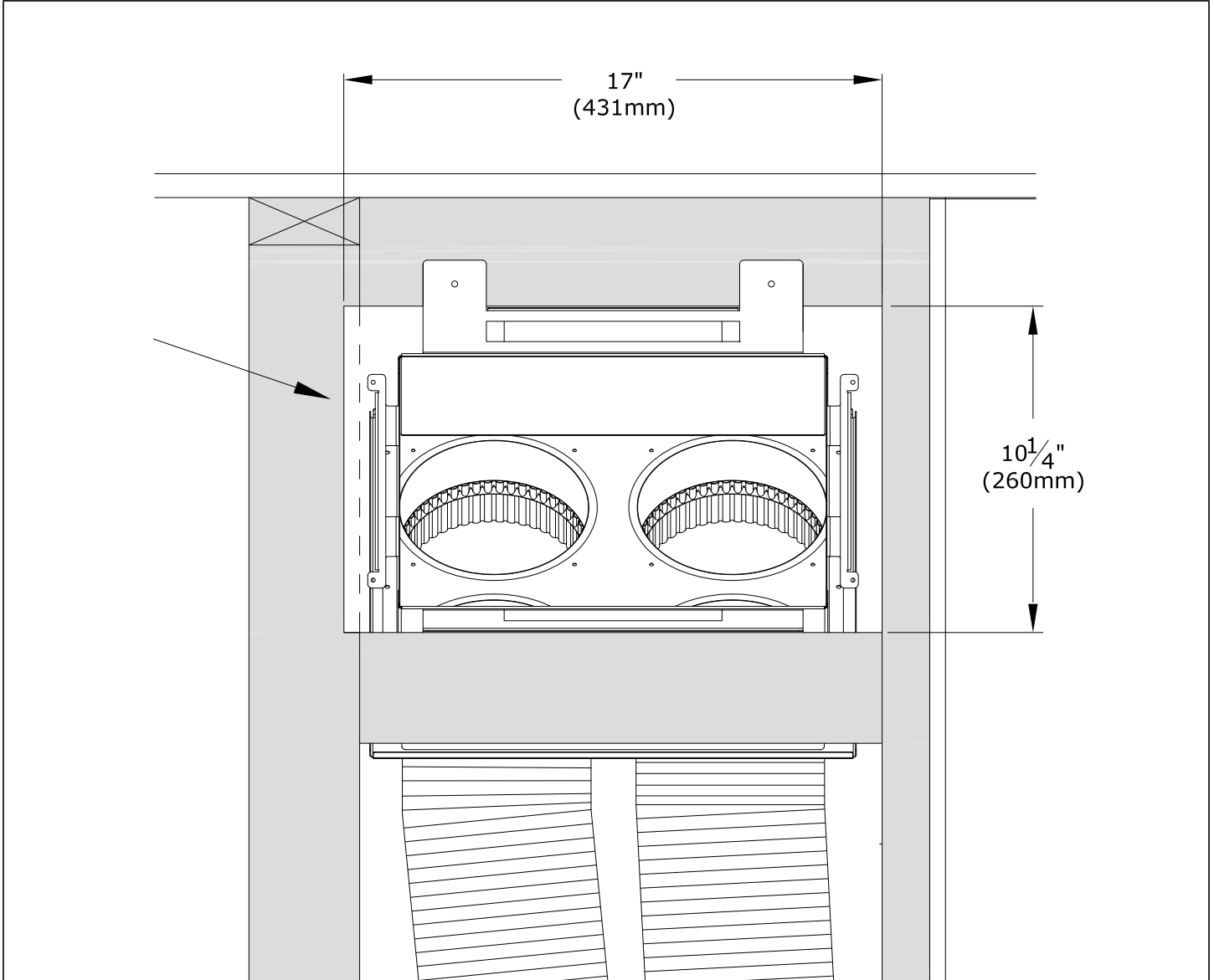

Figure 3.16 - Side KZK - Plenum Framed Opening

3.4.3 Side KZK Opening (continued)

Below is the framing information for the side KZK.

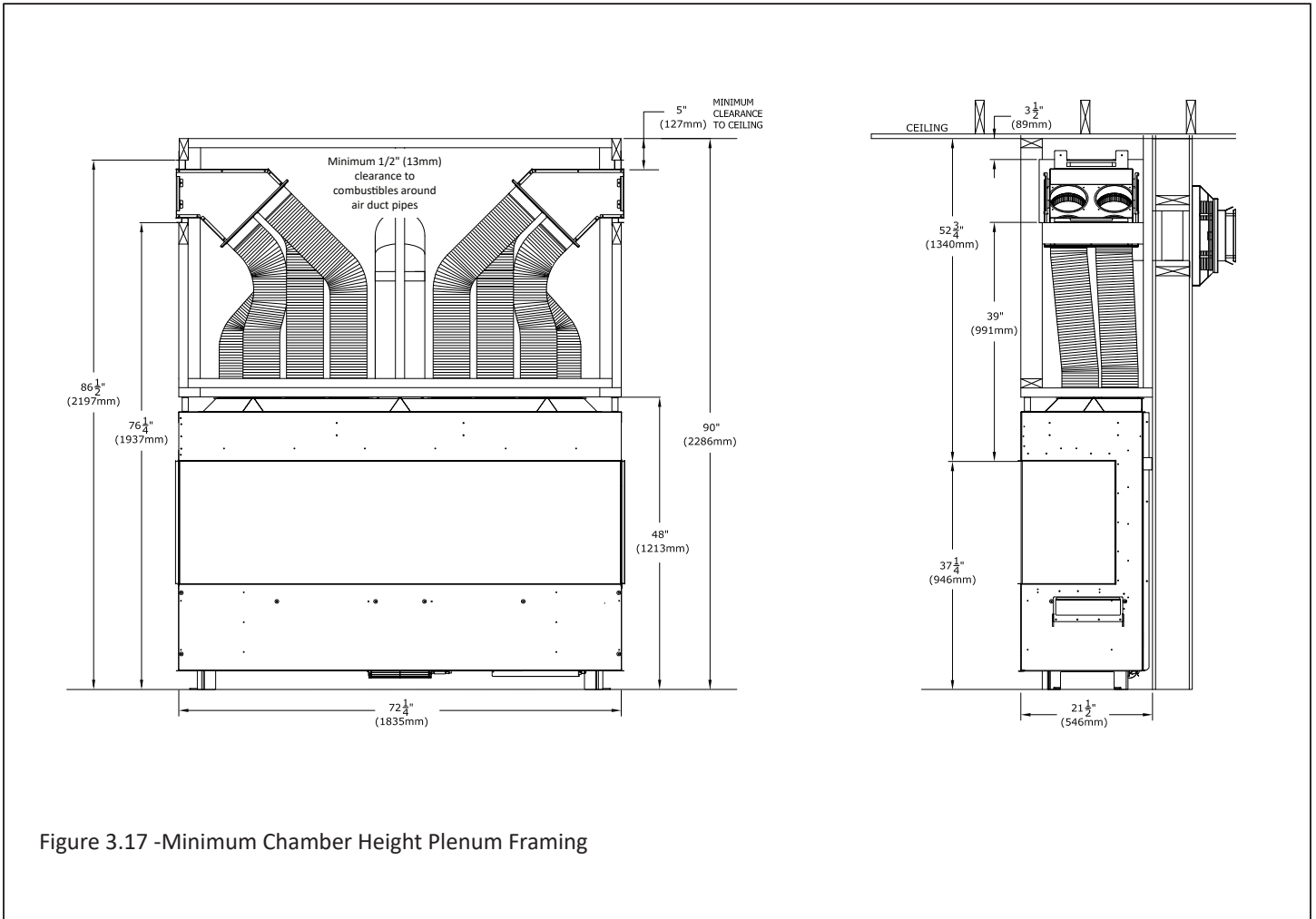

Figure 3.17 -Minimum Chamber Height Plenum Framing

3.4.3 Side KZK (continued)

Shown below in Figure 3.18 are options on how you can finish around the side KZK plenum grilles.

- The left image shows combustible facing material such as drywall finished up to the standoffs around the opening of the plenums. Install the KZK grilles to cover the edge of the finishing material.
- The right image shows the allowed 1" (25mm) thick additional combustible finishing material such as shiplap. This material must stop at the edge of the grilles.

Shown below in Figure 3.19 are options on how you can finish up to finishing edge of the air intake opening. Ensure the 3" (76mm) air intake opening is always maintained throughout all the facing and finishing material.

- The left image shows the 1/2" (13mm) combustible facing material butting up against the finishing edge at the fireplace bottom.
- The middle image shows the allowed 1" (25mm) thick additional combustible finishing material such as shiplap.
- The right image shows non-combustible finishing material such as tile or stone.

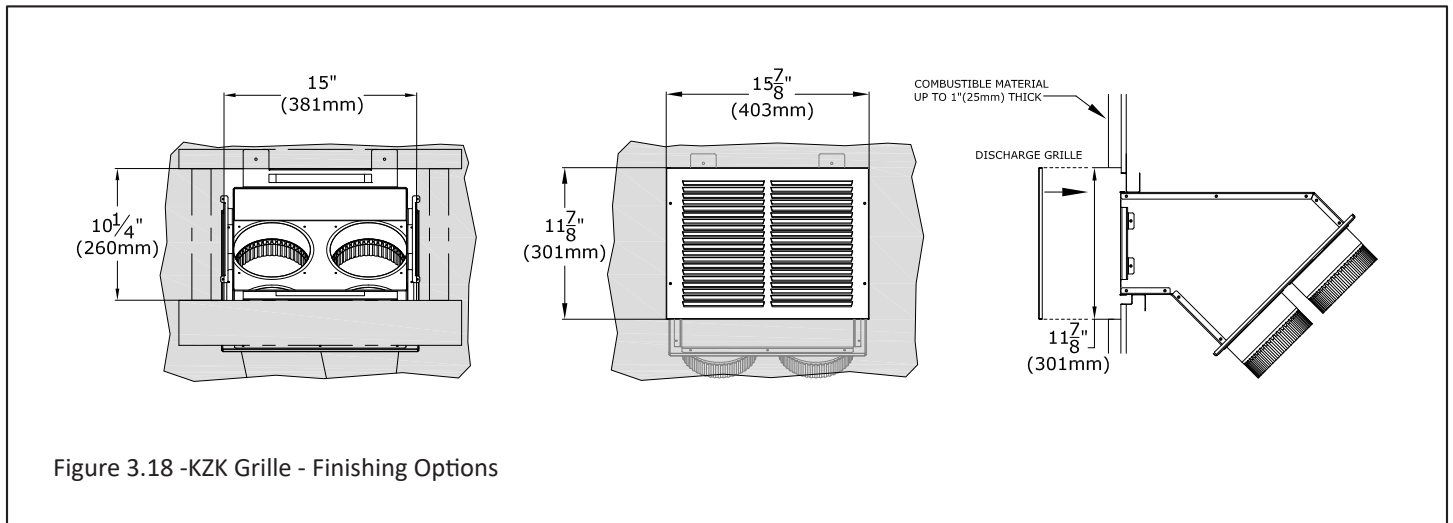

Figure 3.18 -KZK Grille - Finishing Options

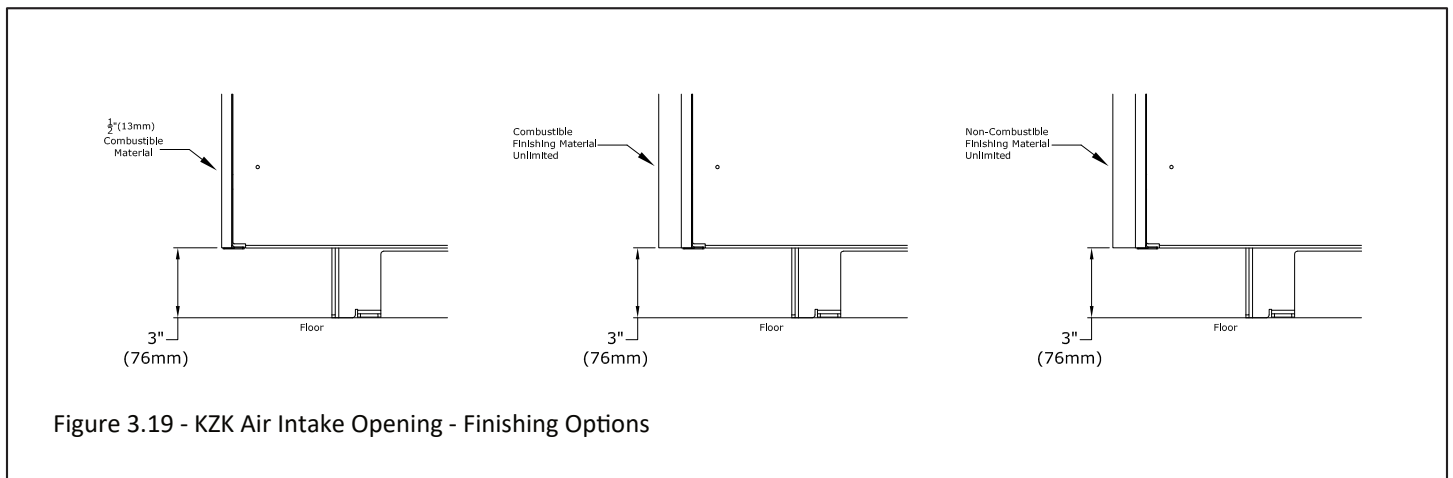

Figure 3.19 - KZK Air Intake Opening - Finishing Options

3.4.4 Vented Cavity Installation Overview

1. Remove the (2) rectangle cover plates located on the top of the fireplace as shown in Figure 3.20. Discard the (2) plates.
2. Slide the fireplace into the framed opening.
3. Frame the rough opening of the vented cavity option you have chosen to maintain minimum clearances to combustibles.

Three-Sided (Bay) Installation - Cover plates are removed for all vented cavity installations shown in section 3.4.5, 3.4.6, and 3.4.7.

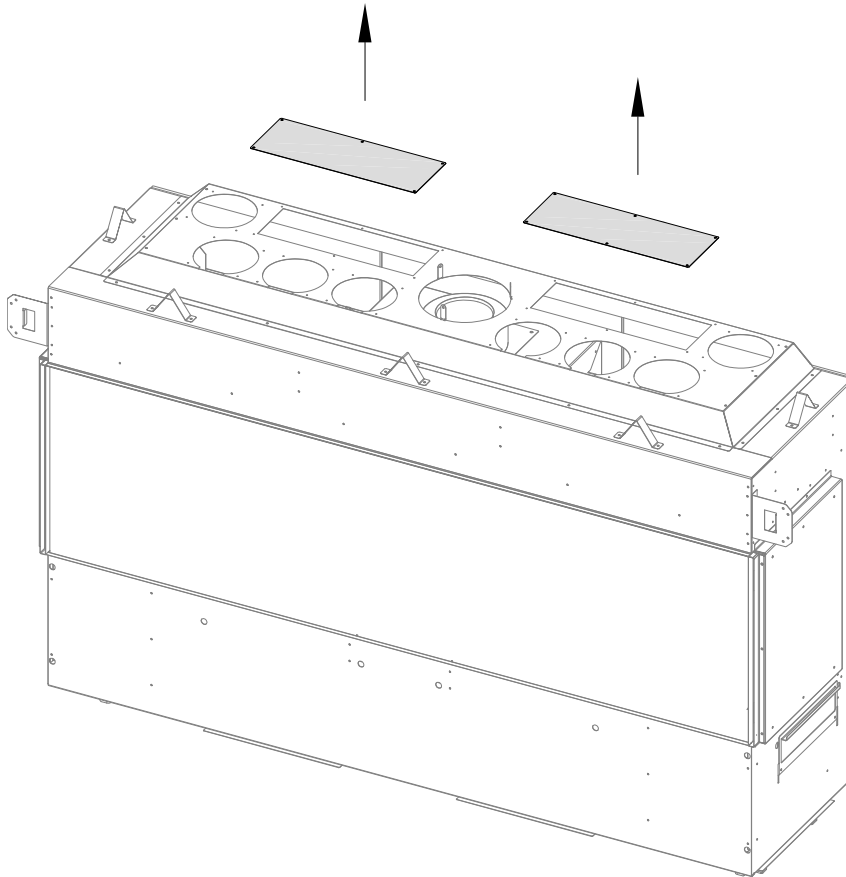
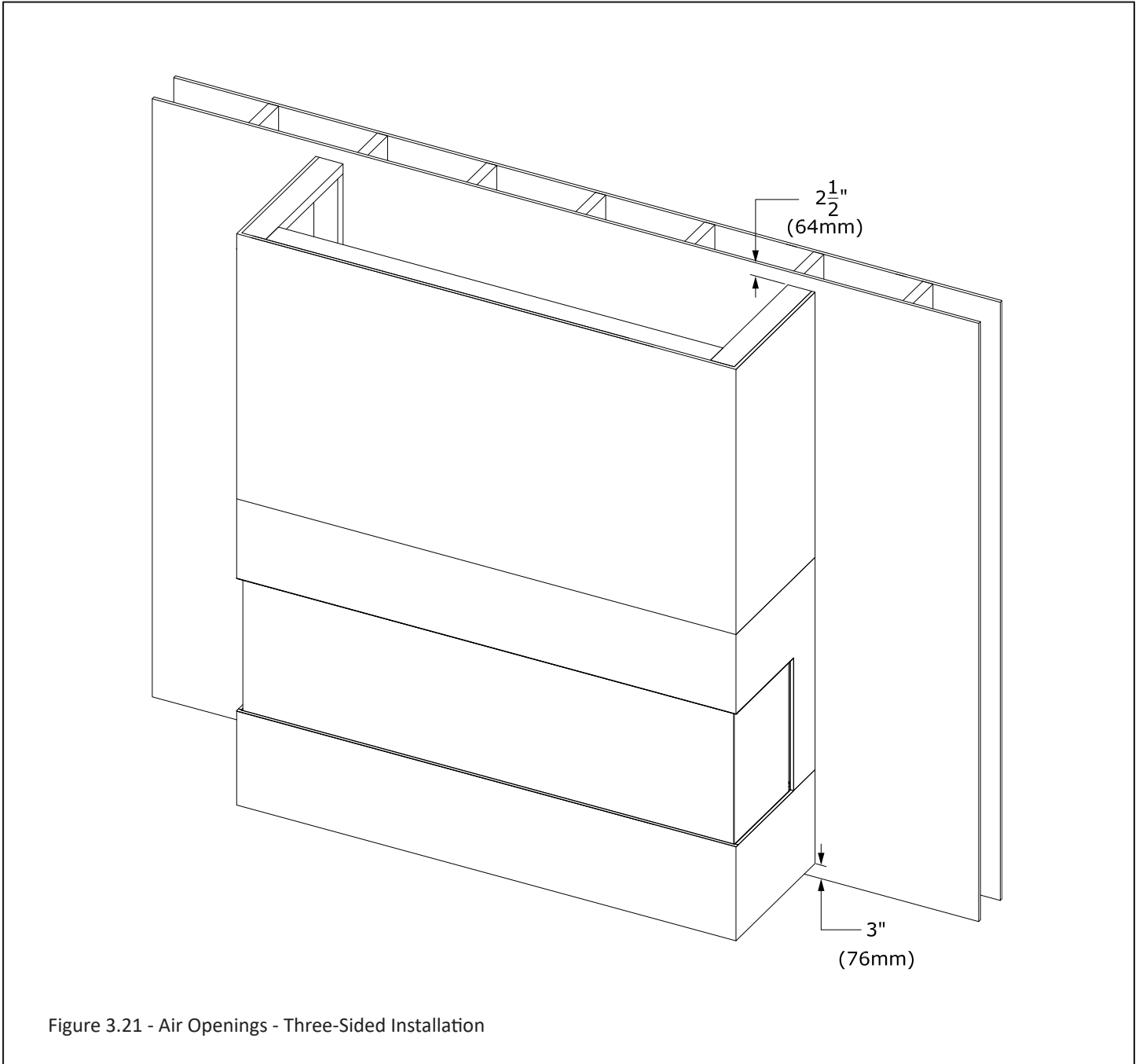

Figure 3.20 - Vented Cavity Cover Plate Removal

3.4.5 Vented Cavity Openings - All Three Sides Of Chamber

Shown below are the minimum requirements for the chamber air intake and heat release openings where the openings are on all three sides of the chamber.



3.4.5 Vented Cavity Openings - All Three Sides Of Chamber (continued)

The figures on this page show how you can visually conceal the heat release opening. This may provide a more desirable appearance. Figure 3.22 shows the use of crown molding. Figure 3.23 shows an overhang.

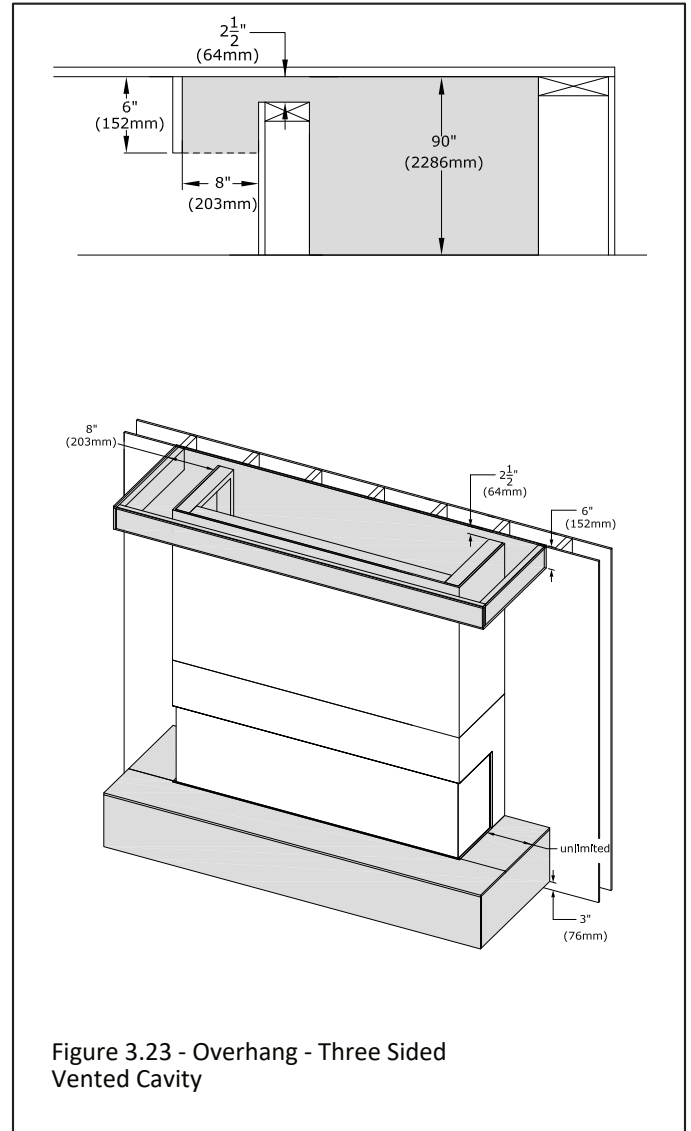
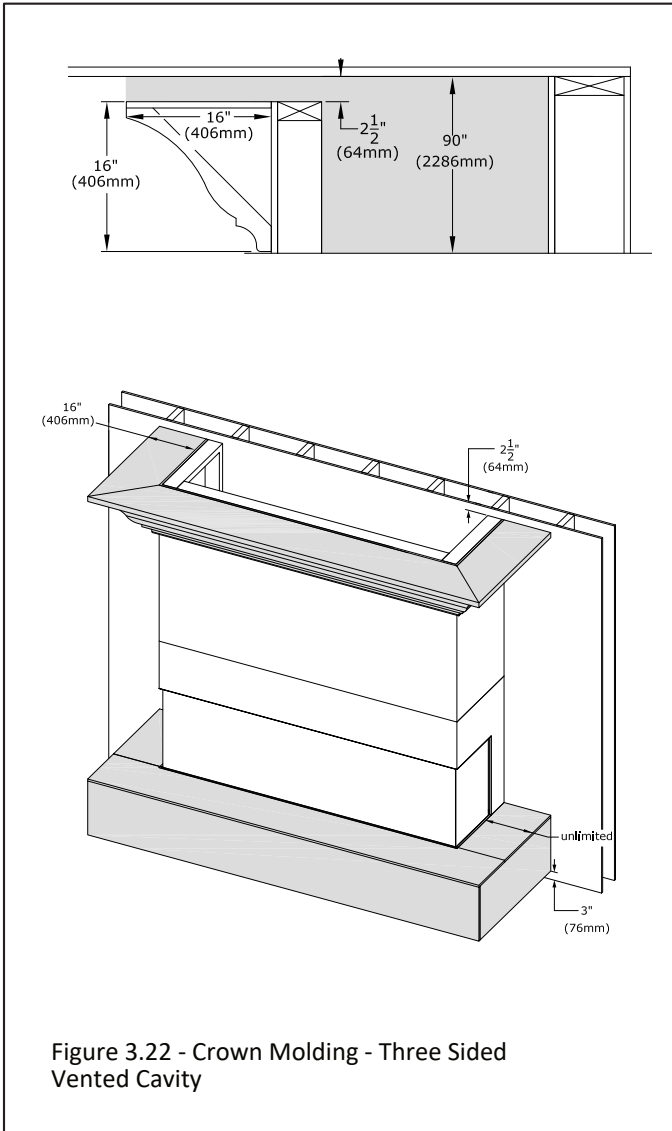

3.4.6 Vented Cavity Openings - Front Of The Chamber

Shown below are the minimum requirements for the chamber air intake and heat release openings where the openings are on the front of the chamber only. The ceiling must be flush with the top of the vented cavity opening.

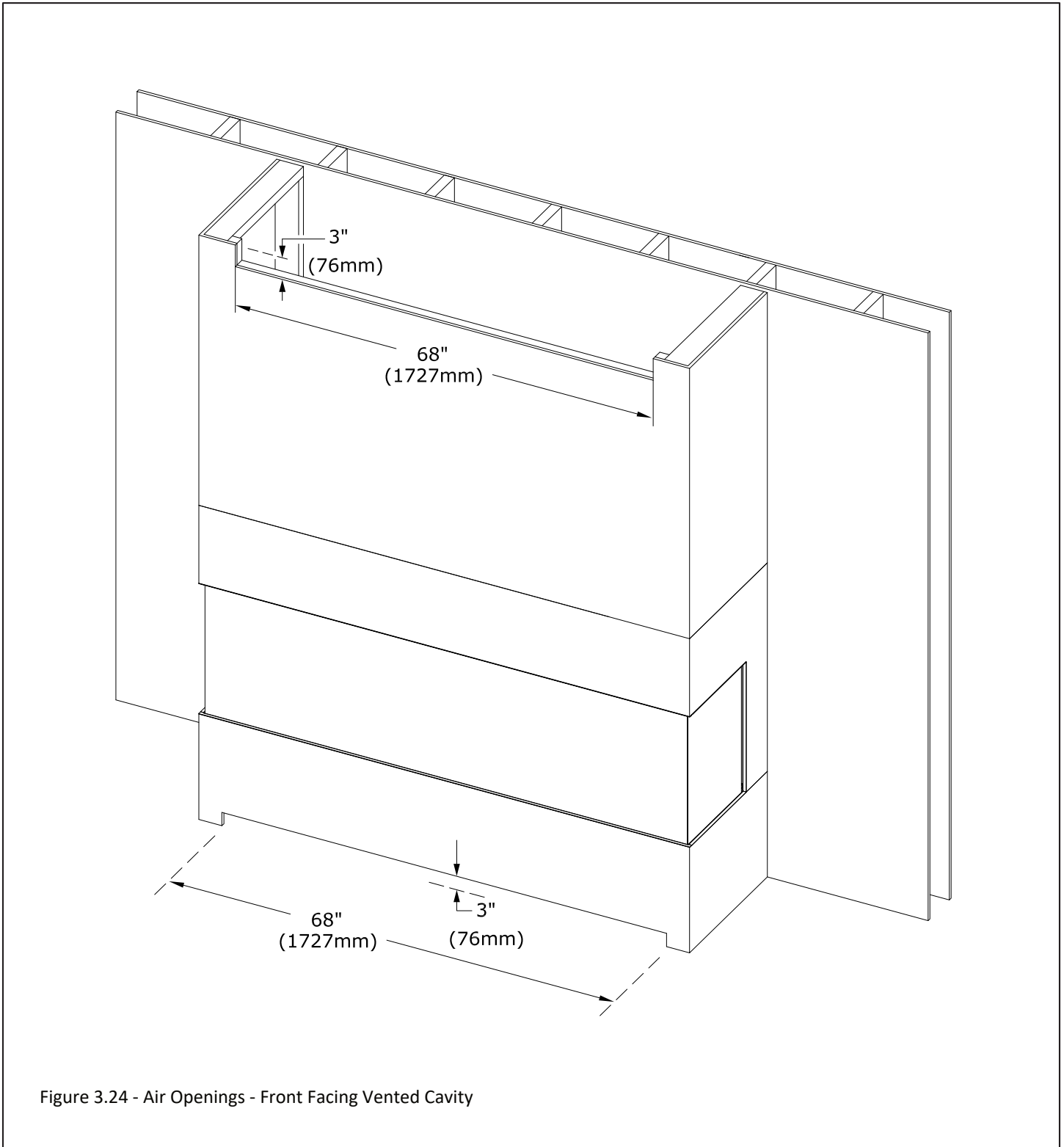
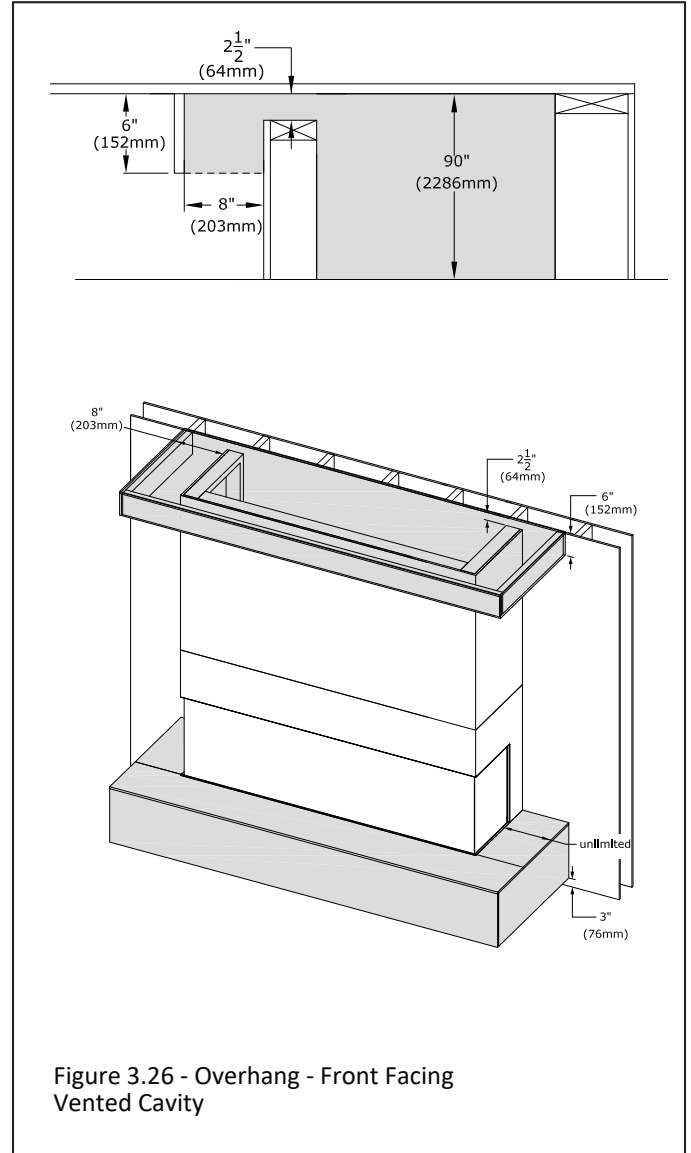
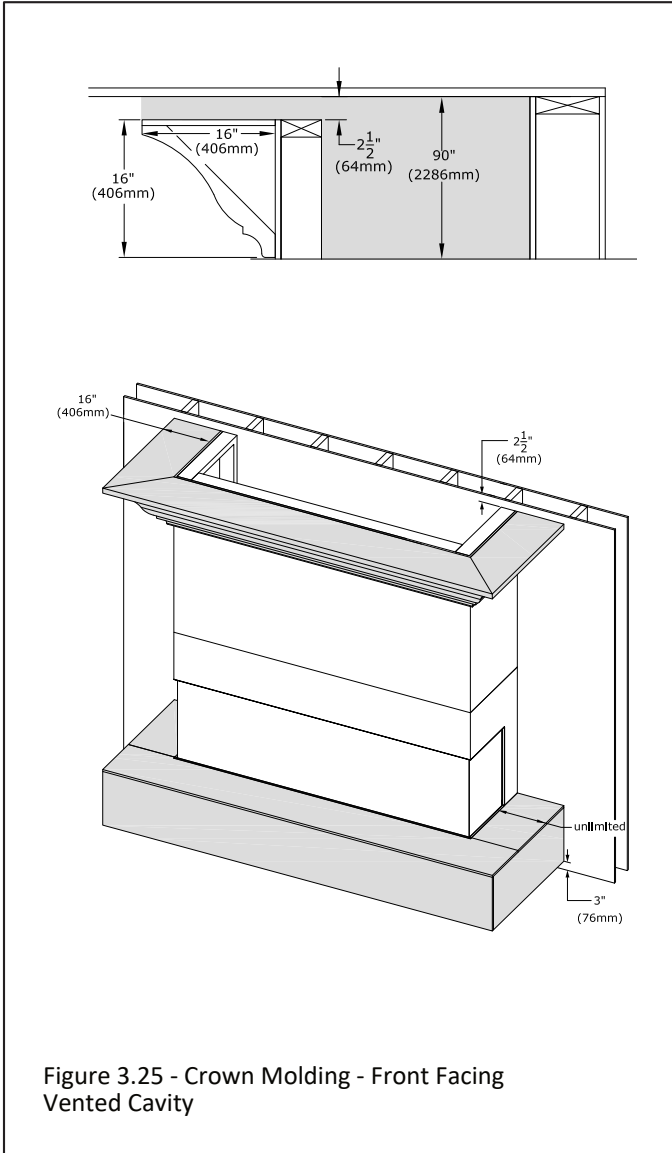

Figure 3.24 - Air Openings - Front Facing Vented Cavity

3.4.6 Vented Cavity Openings - Front Of The Chamber (continued)

The figures on this page show how you can visually conceal the heat release opening. This may provide a more desirable appearance. Figure 3.25 shows the use of crown molding. Figure 3.26 shows an overhang.



3.4.7 Vented Cavity Openings - Combination of Front and Side Openings

See this section for the option of a front chamber air intake and side chamber heat release opening. The minimum requirements are shown in this section. The figure below shows the side heat release opening. You would order part# KZK-SPG3 for the approved side grilles. The louvers of the grille must face down. The ceiling must be flush with the top of the fireplace chamber where the vented cavity opening is placed. You are allowed $\frac{3}{4}$ " (19mm) of material along the top of the vented cavity opening to attach the grill.

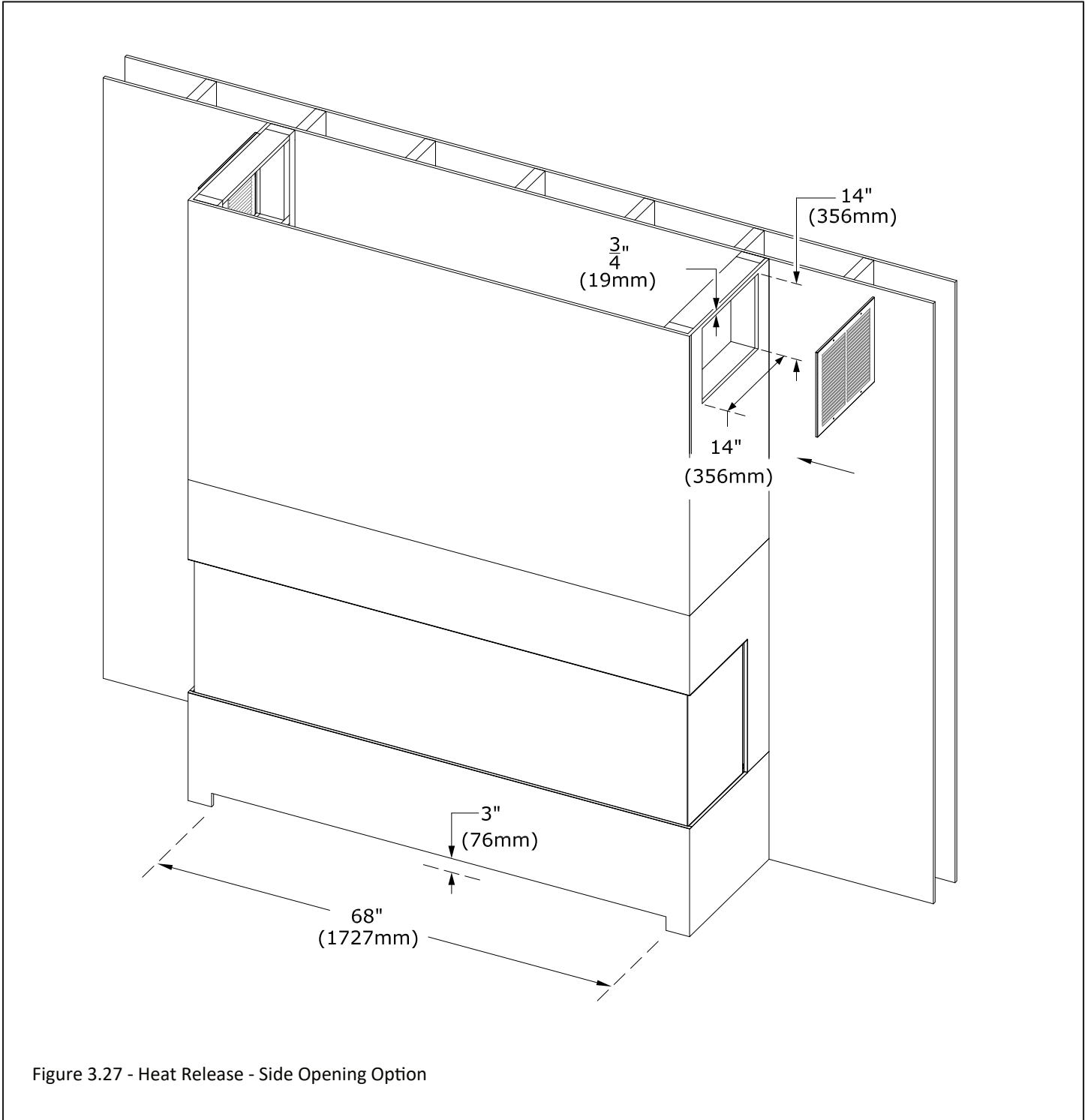

3.5 Hearth, Mantel, Front Chamber, and Side Chamber Projection for KZK Options

NOTE: A maximum of 16" (406mm) total projection is allowed between the mantel and chamber projection (regardless if it is combustible, non-combustible, or a combination). An example would be if you installed a 10" (254mm) front chamber projection then you would be allowed up to a 6" (152mm) mantel until you hit the limit of 16" (406mm).

3.5.1 Combustible Hearth and Mantel Requirements

WARNING: All minimum clearances to combustible material **MUST** be maintained.

- **Combustible Mantel Projections:** A maximum of a 16" (406mm) mantel can be installed flush at the side and top finishing edge. See Figure 3.28.
- **Combustible Chamber Projections:** A maximum of a 16" (406mm) chamber projection can be installed flush at the side and top finishing edge of the fireplace. See Figure 3.29.
- **Combustible Mantel Leg:** A mantel leg can be installed at 0" (0mm) to the fireplace side finishing edge. Refer to Figure 3.30 which shows a combustible projection up to a max of 16" (407mm) on the fireplace side finishing edge.
- **Combustible Hearth:** Combustible hearth can have an unlimited projection. Hearth can be raised flush to the bottom finishing edge. See Figure 3.28.

3.5.2 Non-combustible Mantel and Chamber Projection Requirements

- **Non-combustible Mantel Projections:** A maximum of a 16" (406mm) non-combustible mantel projection is allowed to start at 0" (0mm) from the fireplace top finishing edge.
- **Non-combustible Chamber Projection:** A maximum of a 16" (406mm) non-combustible chamber projection can be installed flush at the front and side finishing edges of the fireplace

IMPORTANT: You are required to have the minimum non-combustible facing material along the front and sides of the fireplace before constructing the framing of the chamber projection. The non-combustible facing material prevents the combustible framing of the chamber projection from directly contacting the fireplace. See Section 3.5.3 for more information.

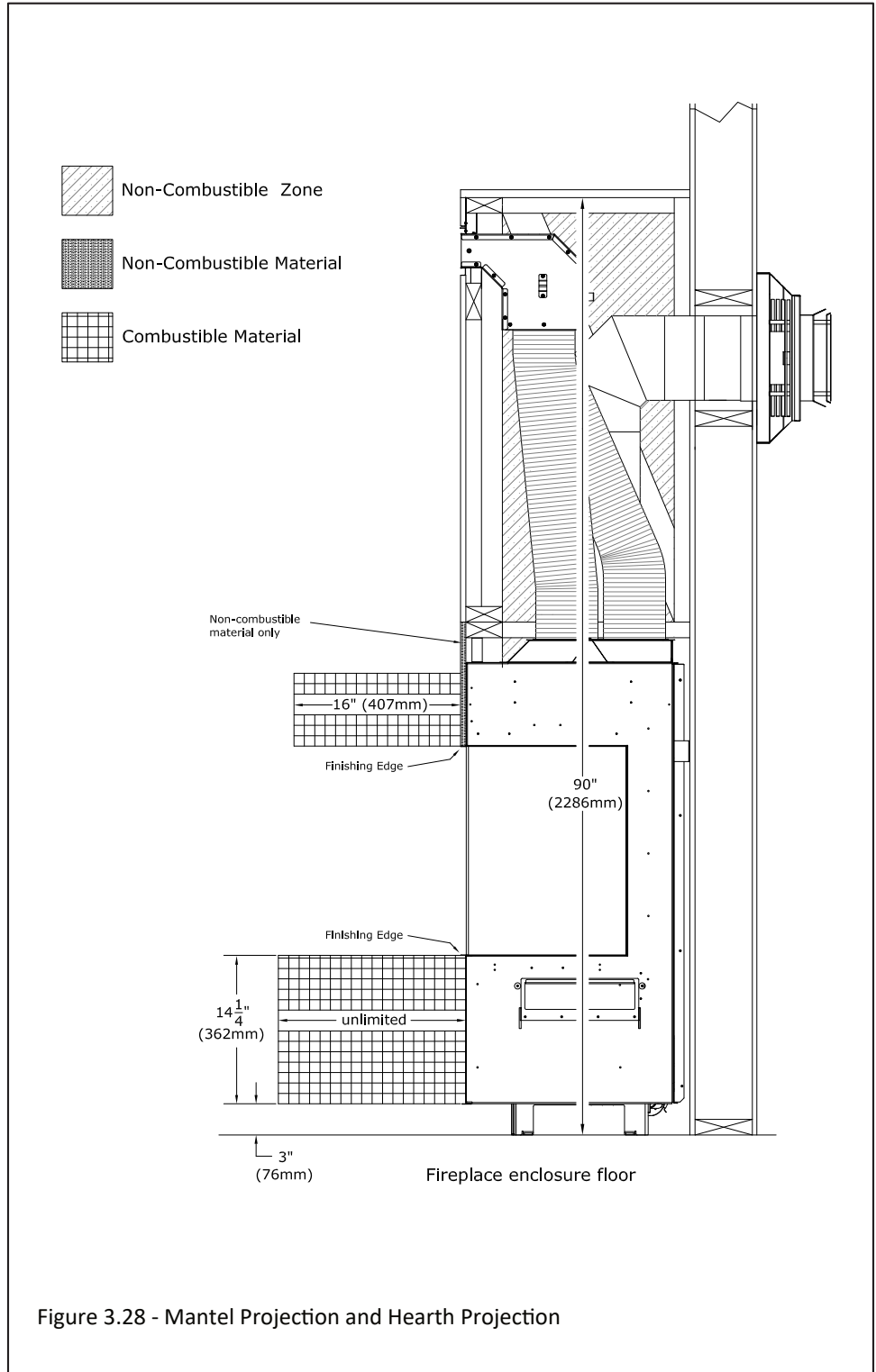

Figure 3.28 - Mantel Projection and Hearth Projection

3.5 Hearth, Mantel, Front Chamber, and Side Chamber Projection for KZK Options (continued)

Figure 3.29 shows the KZK installed in a 16" front chamber projection. The 16" non-combustible projection would also apply to any side chamber projection.

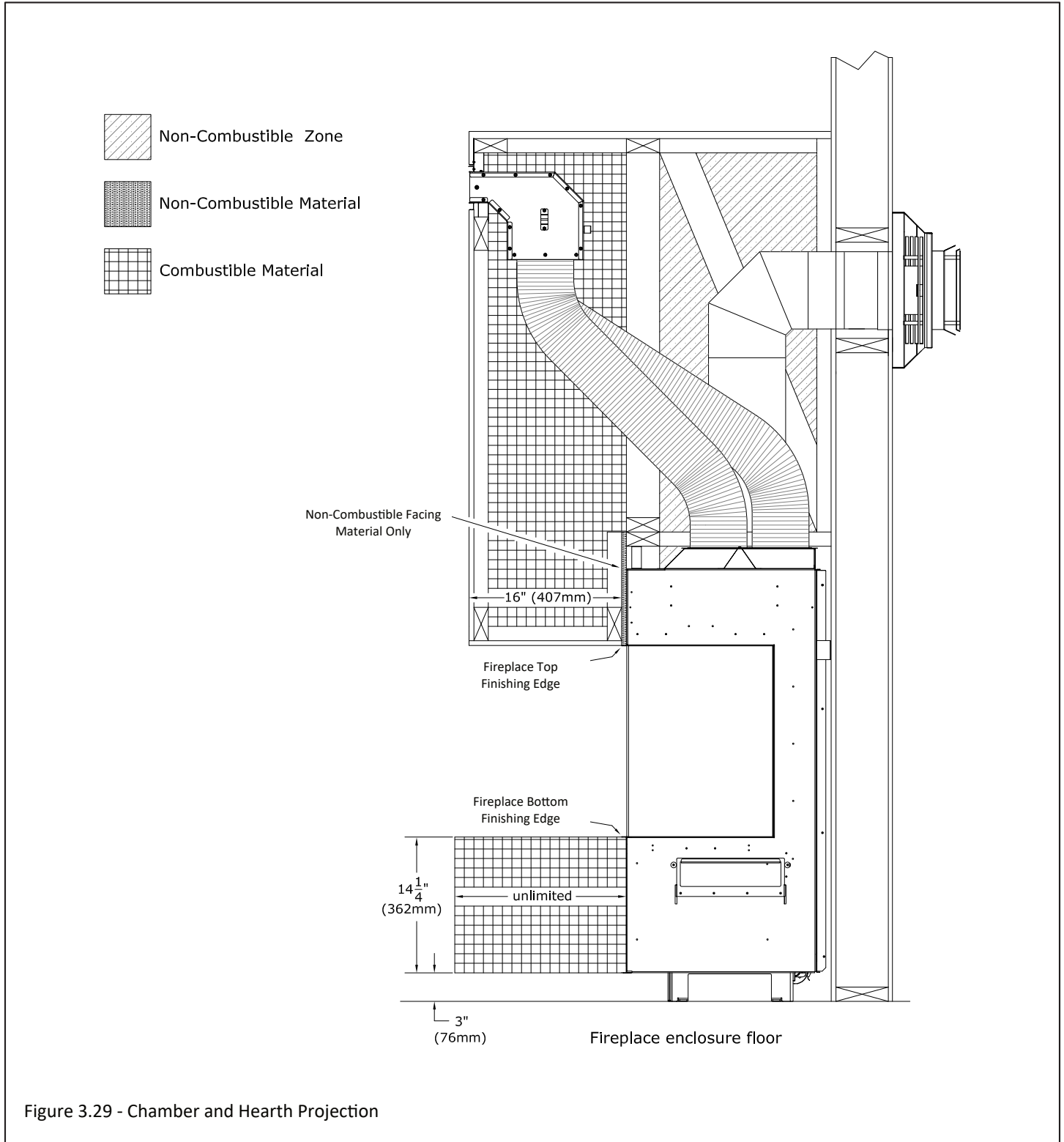

Figure 3.29 - Chamber and Hearth Projection

3.5 Hearth, Mantel, Front Chamber, and Side Chamber Projection for KZK Options (continued)

Figure 3.30 shows a fireplace with a front and side chamber projection with a hearth installed.

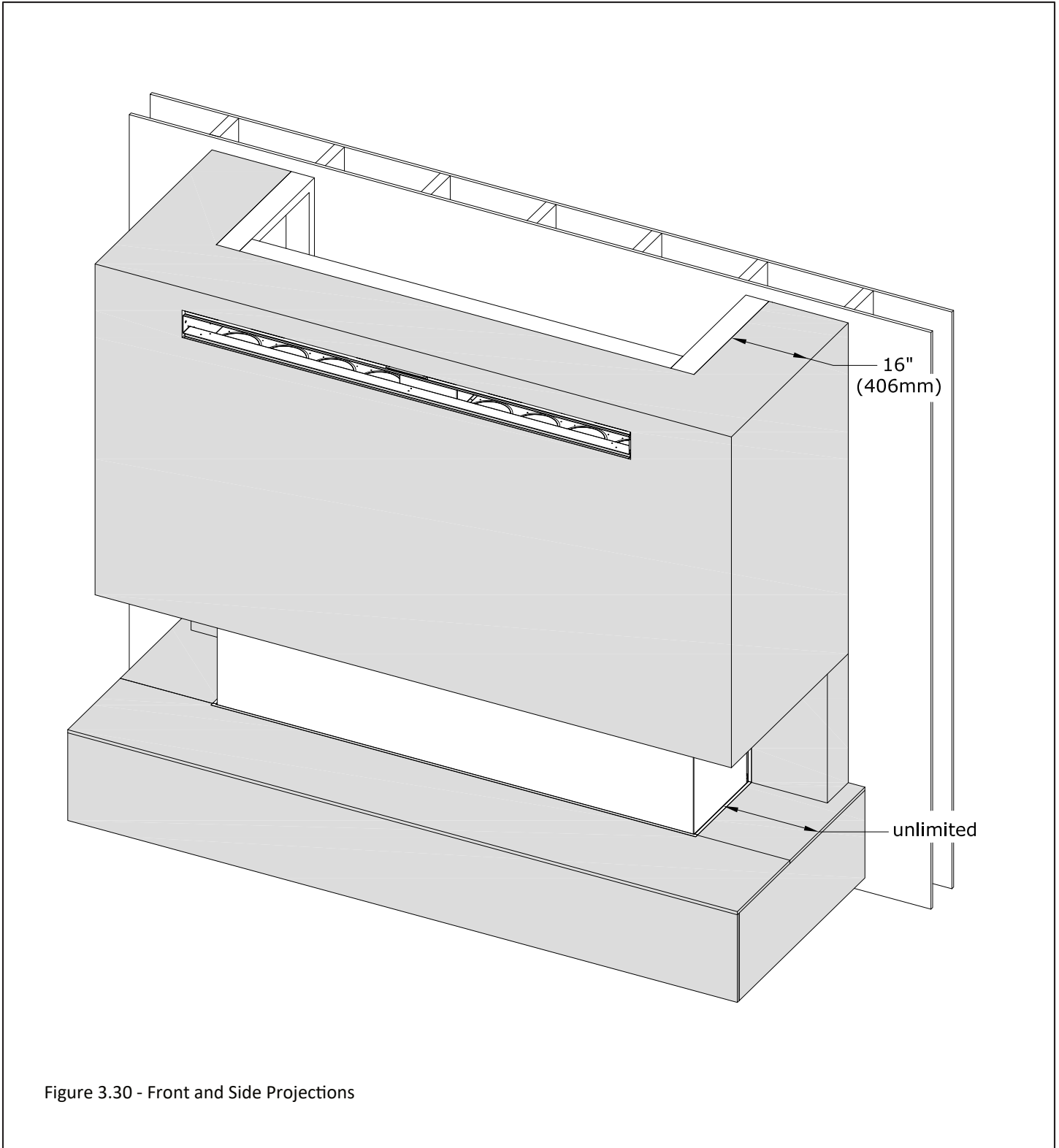

Figure 3.30 - Front and Side Projections

3.5.3 How to Construct a Chamber Projection with a KZK

This section is an overview of the steps in constructing a chamber projection when using a KZK. Figures 3.31 and 3.32 show a front KZK (KZK-068) application but would apply to side KZK (KZK-1510B) as well. The fireplace chamber does NOT need to be sealed separately from the front projection. This is because the air will heat up and rise through the KZK air duct pipes and exit through the KZK plenum(s).

- Frame out the chamber above the fireplace. Install the required non-combustible facing material as required in Section 3.3.

NOTE: This non-combustible facing material is only required if you intend on using combustible framing for the projection. If you use non-combustible framing then it can come into direct contact with the fireplace (non-combustible facing material is not required).

- Next frame out the projection and install the KZK. Lastly install the facing material and finishing material.

IMPORTANT: Maintain 1/2" (13mm) clearance around the KZK air duct pipes to anything combustible.

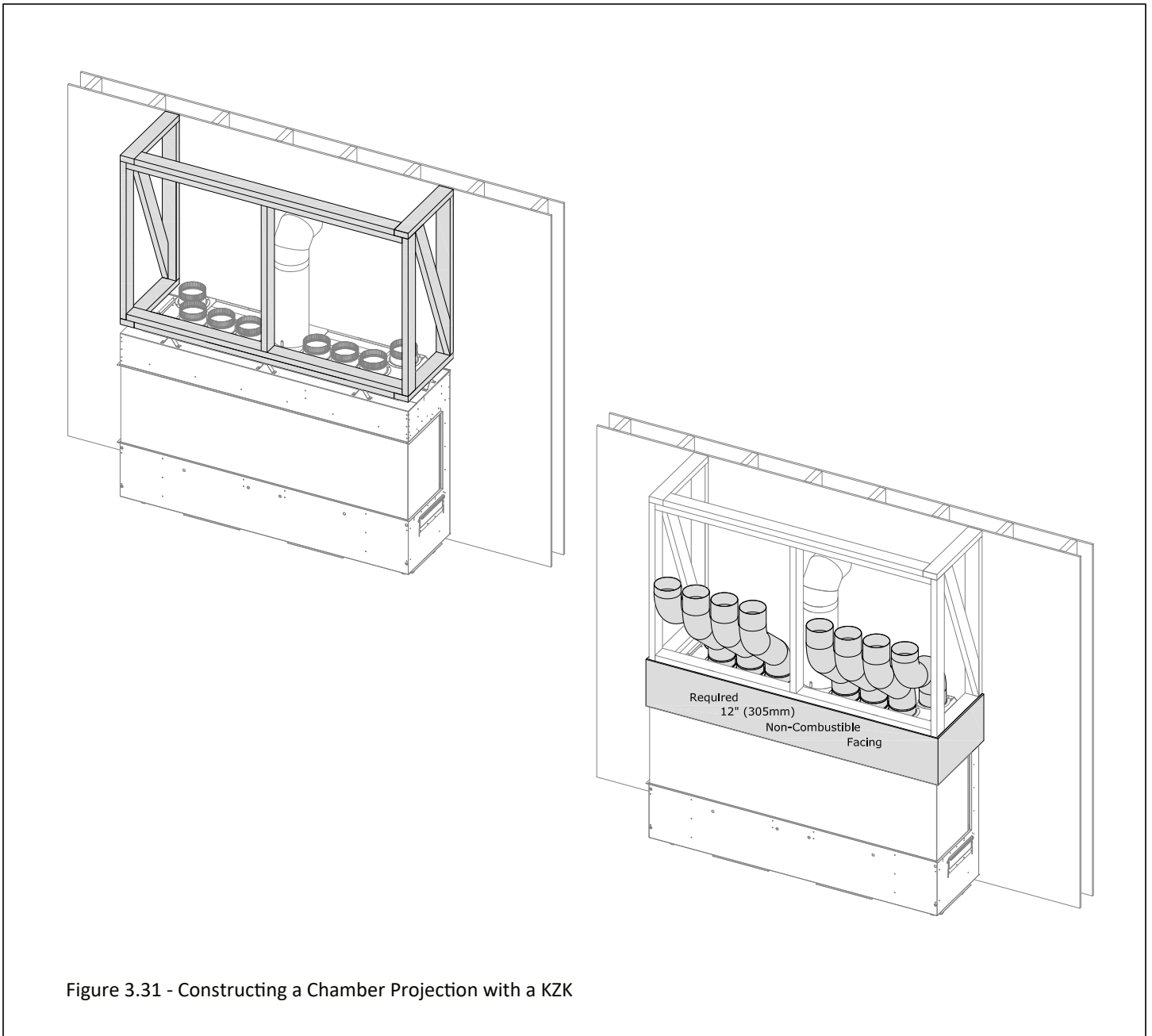

Figure 3.31 - Constructing a Chamber Projection with a KZK

3.5.3 How to Construct a Chamber Projection with a KZK (continued)

IMPORTANT: Maintain 1/2" (13mm) clearance around the KZK air duct pipes to anything combustible.

- The top left image shows the start of the framing process. Ensure framing distances to fireplace finishing edges accommodate finishing material.
- The bottom right image shows the finished chamber and hearth projection.

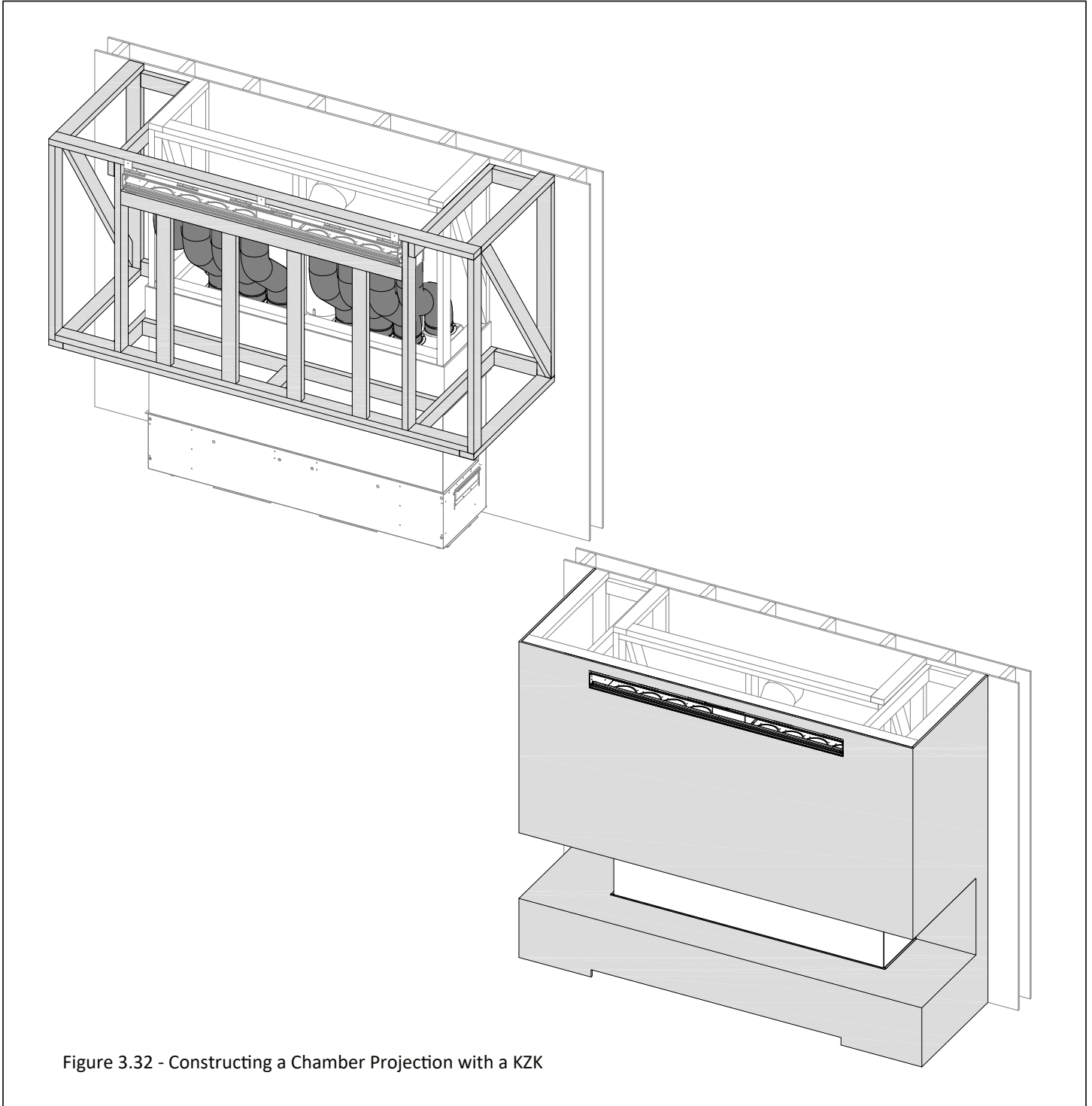

Figure 3.32 - Constructing a Chamber Projection with a KZK

3.6 Hearth, Mantel, Front Chamber, and Side Chamber Projection for Vented Cavity Options

NOTE: A maximum of 16" (406mm) total projection is allowed between the mantel and chamber projection (regardless if it is combustible, non-combustible, or a combination). An example would be if you installed a 10" (254mm) front chamber projection then you would be allowed up to a 6" (152mm) mantel until you hit the limit of 16" (406mm).

3.6.1 Combustible Hearth and Mantel Requirements

WARNING: All minimum clearances to combustible material **MUST** be maintained.

- **Combustible Mantel Projections:** A maximum of a 16" (406mm) mantel can be installed flush at the side and top finishing edge. See Figure 3.33.
- **Combustible Chamber Projections:** A maximum of a 16" (406mm) chamber projection can be installed flush at the side and top finishing edge of the fireplace. See Figure 3.34.
- **Combustible Mantel Leg:** A mantel leg can be installed at 0" (0mm) to the fireplace side finishing edge. Refer to Figure 3.35 which shows a combustible projection up to a max of 16" (407mm) on the fireplace side finishing edge.
- **Combustible Hearth:** Combustible hearth can have an unlimited projection. Hearth can be raised flush to the bottom finishing edge. See Figure 3.33.

3.6.2 Non-combustible Mantel and Chamber Projection Requirements

- **Non-combustible Mantel Projections:** A maximum of a 16" (406mm) non-combustible mantel projection is allowed to start at 0" (0mm) from the fireplace top finishing edge.
- **Non-combustible Chamber Projection:** A maximum of a 16" (406mm) non-combustible chamber projection can be installed flush at the front and side finishing edges of the fireplace.

IMPORTANT: You are required to have the minimum non-combustible facing material along the front and sides of the fireplace before constructing the framing of the chamber projection. The non-combustible facing material prevents the combustible framing of the chamber projection from directly contacting the fireplace. See Section 3.6.3 for more information.

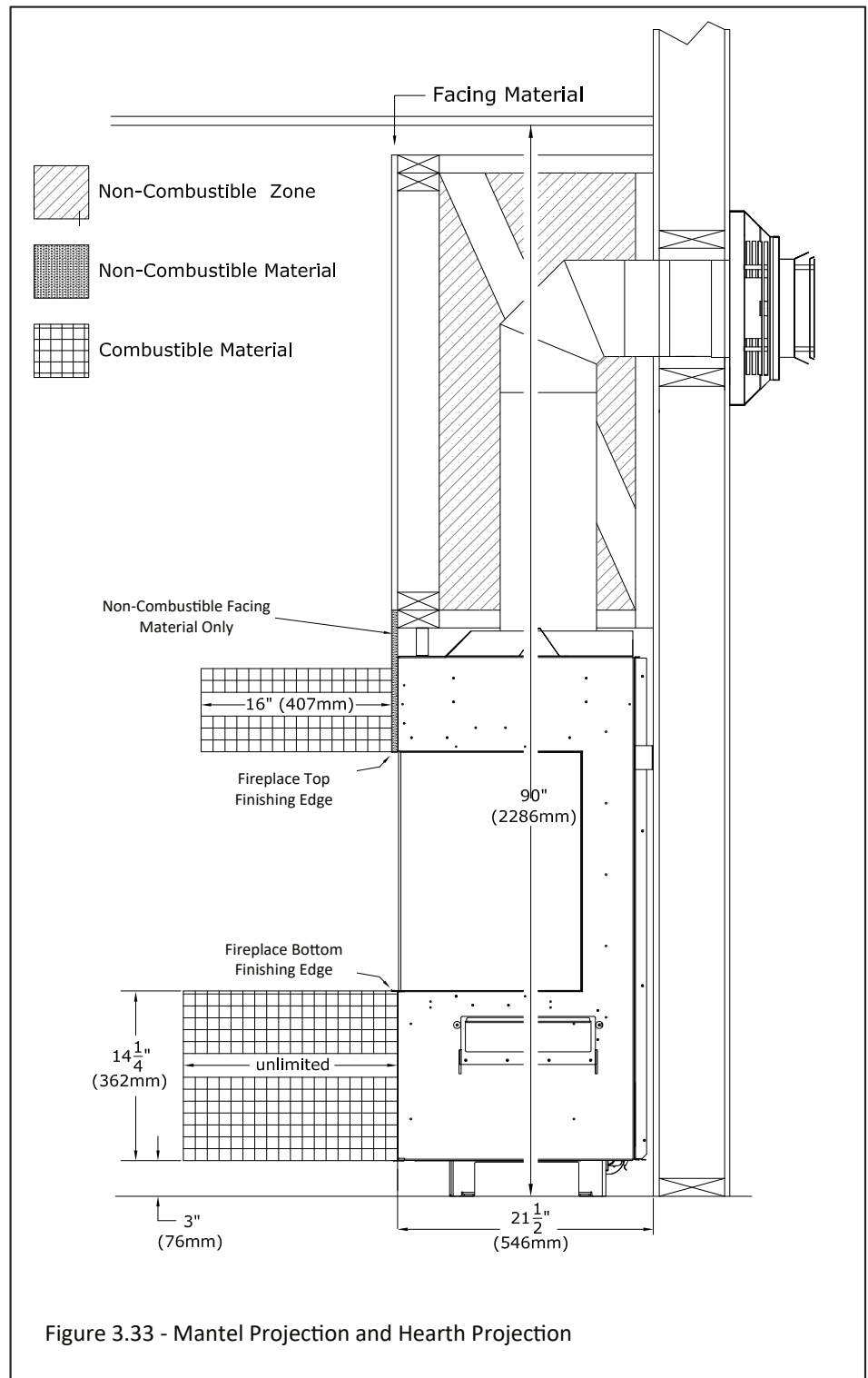

Figure 3.33 - Mantel Projection and Hearth Projection

3.6 Hearth, Mantel, Front Chamber Projection, and Side Chamber Projection for Vented Cavity Options (continued)

Figure 3.34 shows a 16" front chamber projection with a vented cavity. The air intake and heat release openings of the fireplace chamber must maintain their clearances for the option you have chosen throughout the entire fireplace chamber and projection. The hearth projection is unlimited.

IMPORTANT: It is required to install facing material on the fireplace chamber before constructing the chamber projection. This is required to ensure the convective cooling process of the fireplace functions correctly. See Section 3.6.3 on how to construct the chamber projection.

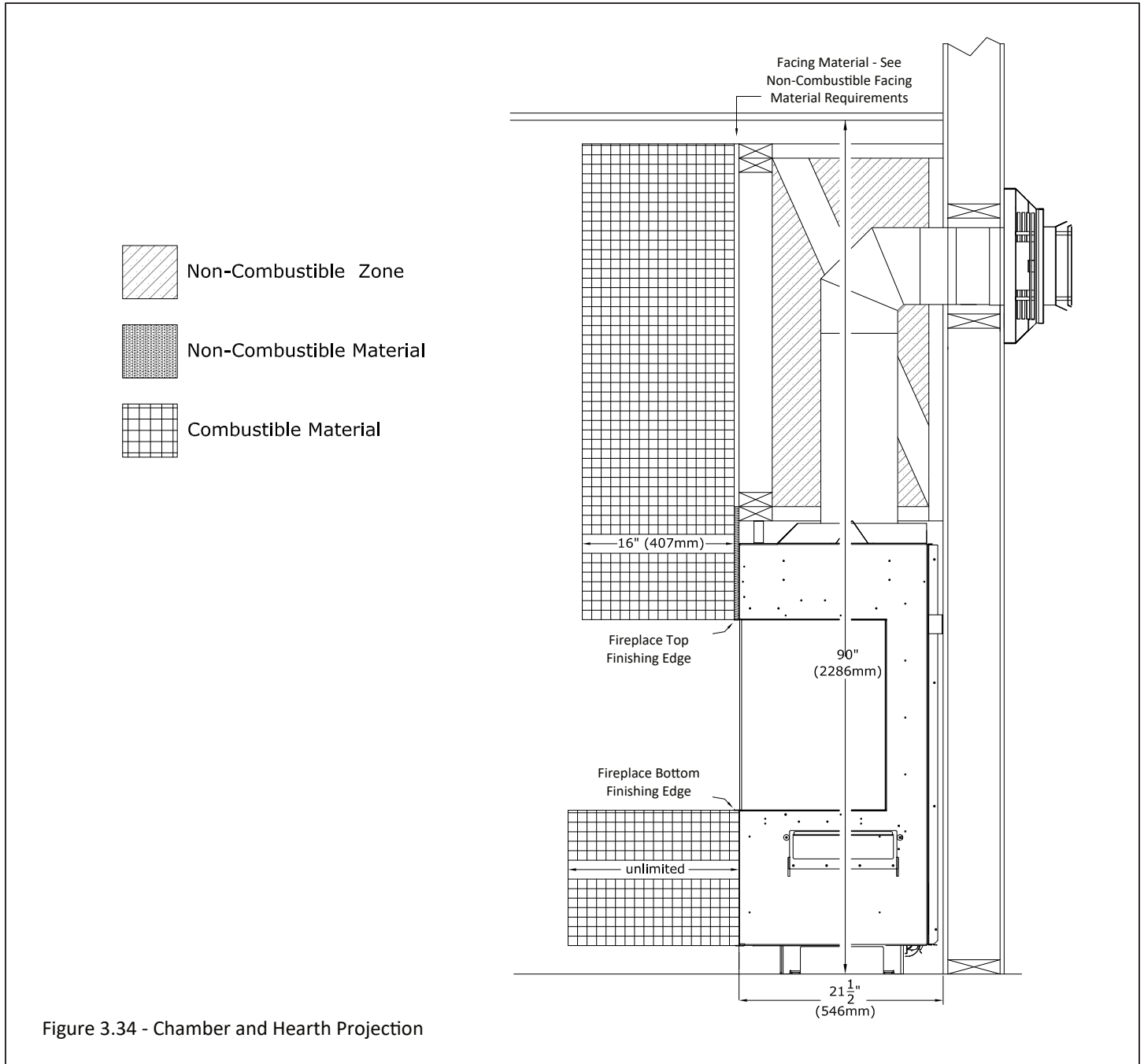

Figure 3.34 - Chamber and Hearth Projection

3.6 Hearth, Mantel, Front Chamber Projection, and Side Chamber Projection for Vented Cavity Options (continued)

Figure 3.35 shows a fireplace with a front and side chamber projection with a hearth installed.

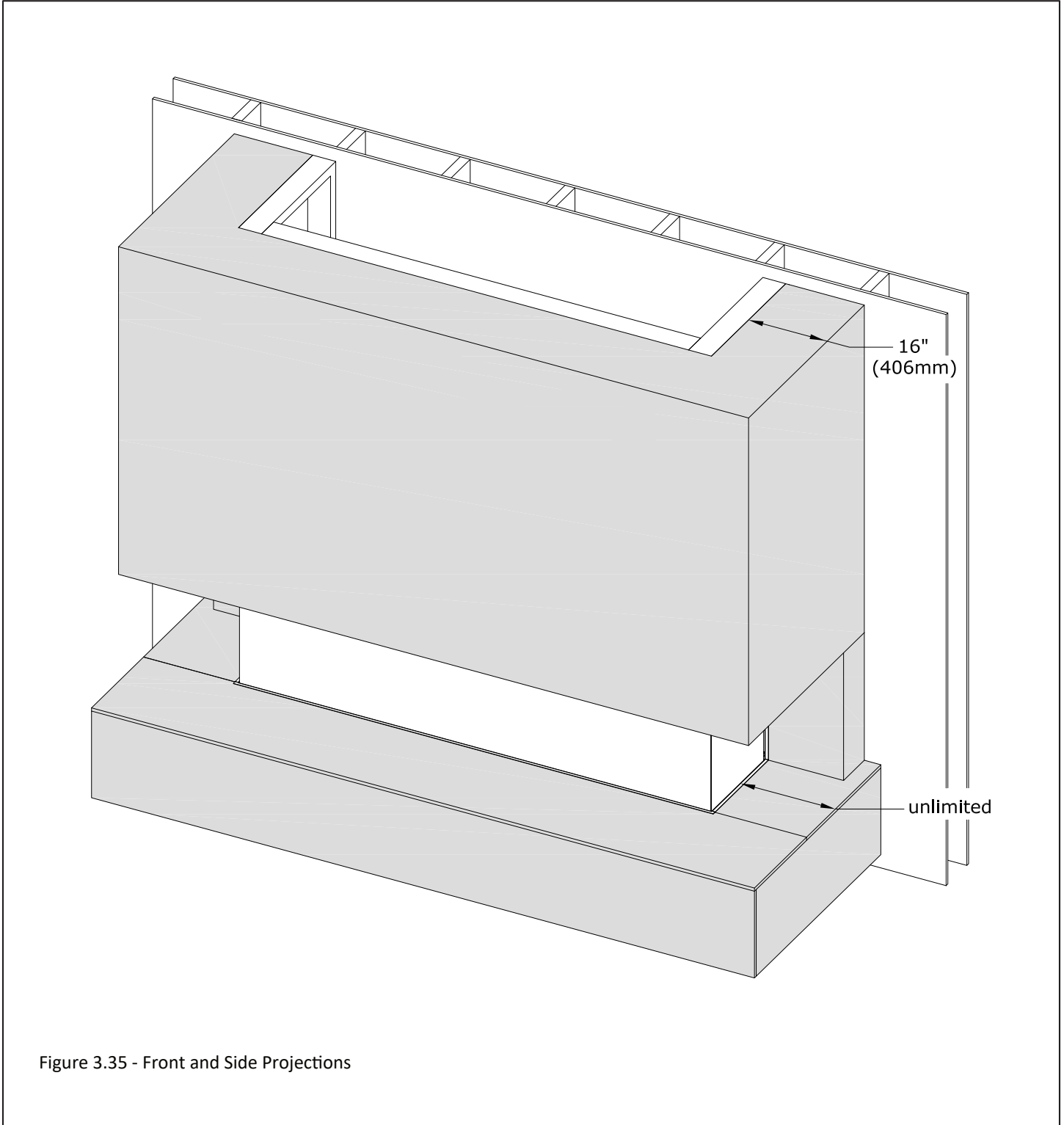
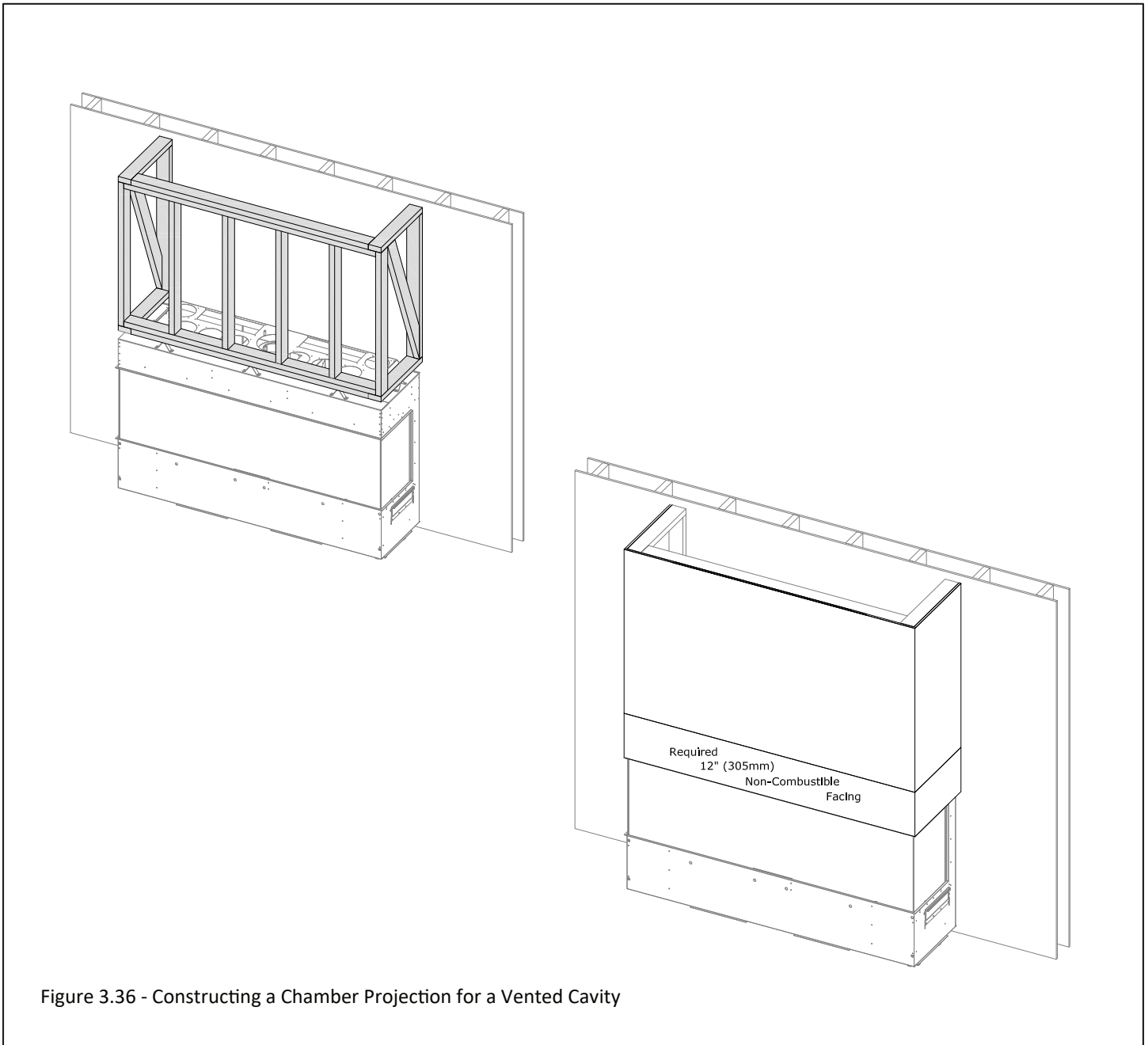

Figure 3.35 - Front and Side Projections

3.6.3 How to Construct a Chamber Projection with a Vented Cavity

This section is an overview of the steps in constructing a chamber projection when using a Vented Cavity. Figures 3.36 and 3.37 show a vented cavity that is open on all three sides of the chamber. You are required to construct the fireplace chamber and then install facing material first to ensure the convective cooling process of air entering the fireplace chamber at the bottom and discharging at the top of the chamber via the opening option you have chosen. The convective cooling process of the fireplace chamber is essential for proper function of the safety glass barrier and clearance to combustibles of the fireplace chamber.

- Frame out the chamber above the fireplace. Install all the facing material across the entire fireplace chamber which will seal the fireplace chamber from the projection. Pay attention to the required non-combustible facing material as required in Section 3.3.
- Next frame out the projection and ensure the vented cavity air opening maintains the required clearances. Lastly install the facing material and finishing material on the projection. The minimum dimensions of the air intake openings and heat release openings that you choose are required to be maintained in the initial fireplace chamber and throughout the projection.



3.6.3 How to Construct a Chamber Projection with a Vented Cavity (continued)

- The top left image shows the start of the framing process. Ensure framing distances to fireplace finishing edges accommodate finishing material.
- The bottom right image shows the finished chamber and hearth projection.

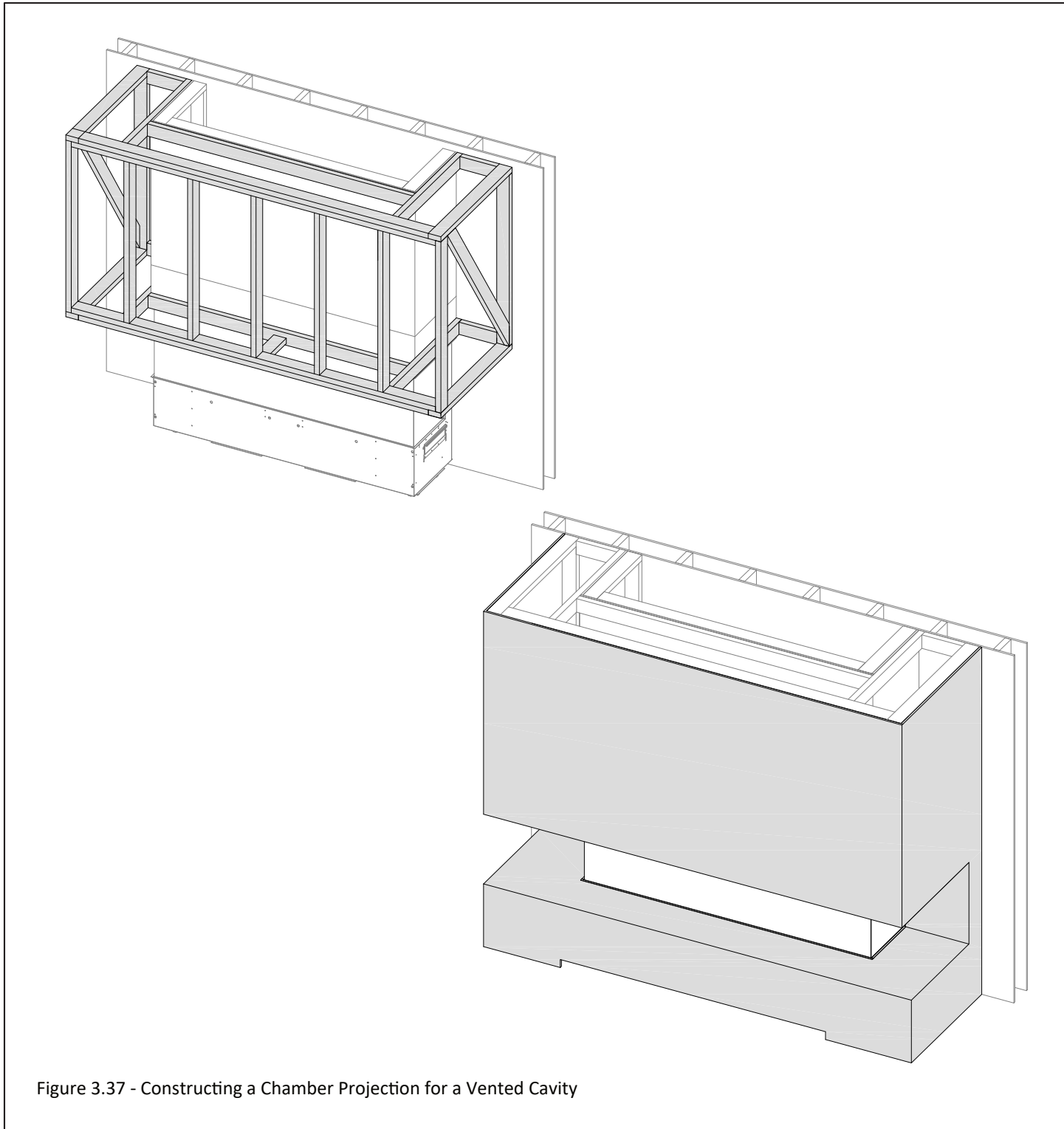
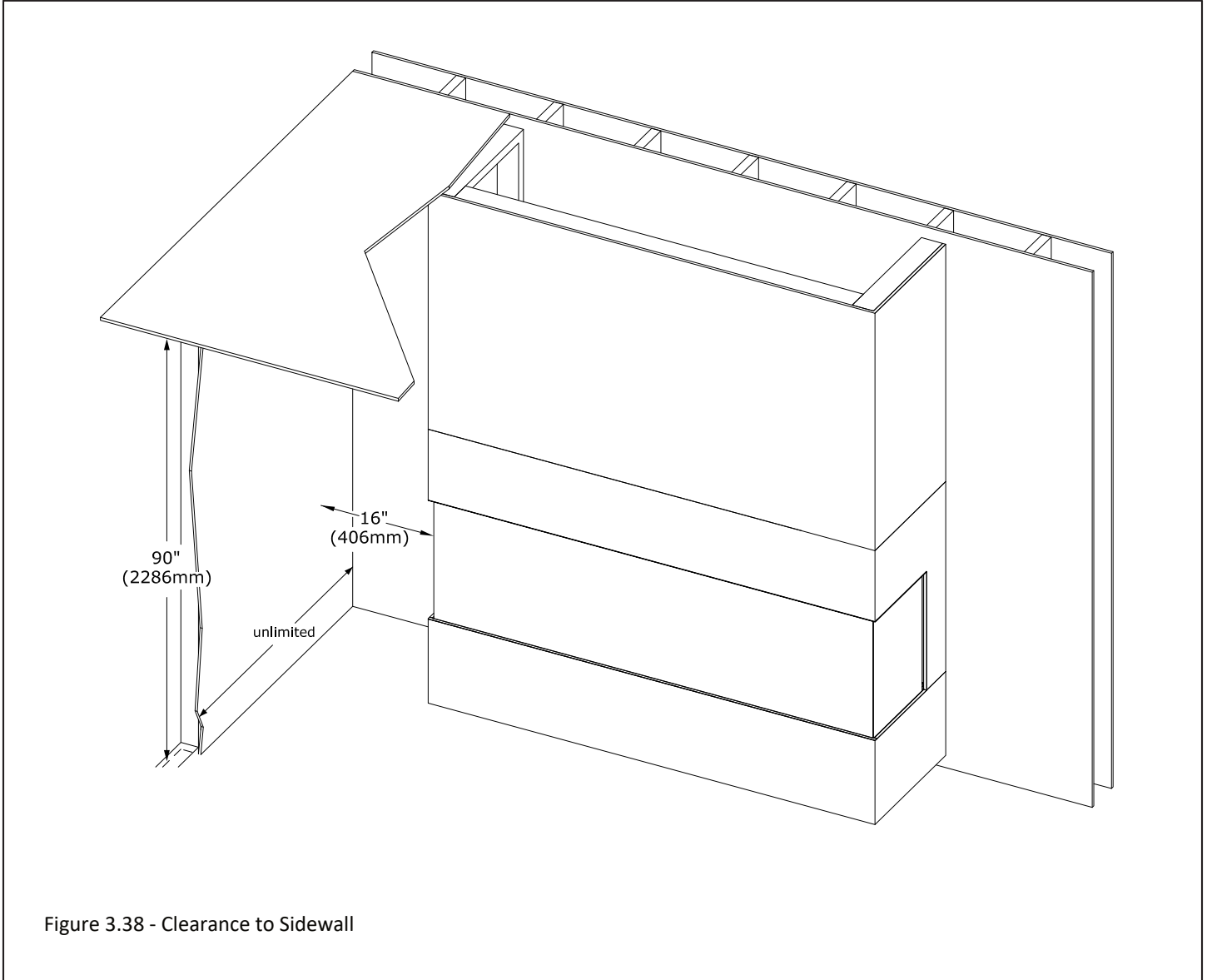

Figure 3.37 - Constructing a Chamber Projection for a Vented Cavity

3.7 Clearance to a Sidewall

The sidewall clearance is taken from the fireplace side finishing edge to the sidewall. The minimum clearance of 16" (406mm) applies to all Vented Cavity and KZK options.



4.0 Fireplace Setup

4.1 Safety Glass Barriers

WARNING: Do not operate this fireplace with the glass removed, cracked, or broken. Replacement of the glass assembly, should be done by a licensed or qualified service person. If a safety glass barrier becomes damaged, it shall be replaced with the manufacturer's safety glass barrier for this appliance.

The safety glass barrier for this fireplace is tempered glass.

A safety glass barrier designed to reduce the risk of burns from the hot viewing glass is provided with this appliance and shall be installed for the protection of children and other at-risk individuals.

4.1.1 Removing The Safety Glass Barrier Assembly

WARNING: Do not remove the glass assembly when hot.

1. Attach a suction cup to the side safety glass barrier pieces. Slide them towards the back of the fireplace to leave an approximate 1/4"-1/2" (6-13mm) gap between the side glass and the front glass. Next attach the suction cups to the front safety glass barrier. Remove the front safety glass barrier pieces as shown in Figure 4.1. Lift up the safety glass barrier and tilt the bottom edge of the glass towards you. Move the glass down and out to remove. Note: Depending on your fireplace configuration you may have one or two side safety glass barrier pieces.
2. After removing the front piece you can remove the side safety glass barrier pieces. First move the safety glass barrier forward in the fireplace to its original position and then follow same removal instructions as performed with the front piece.

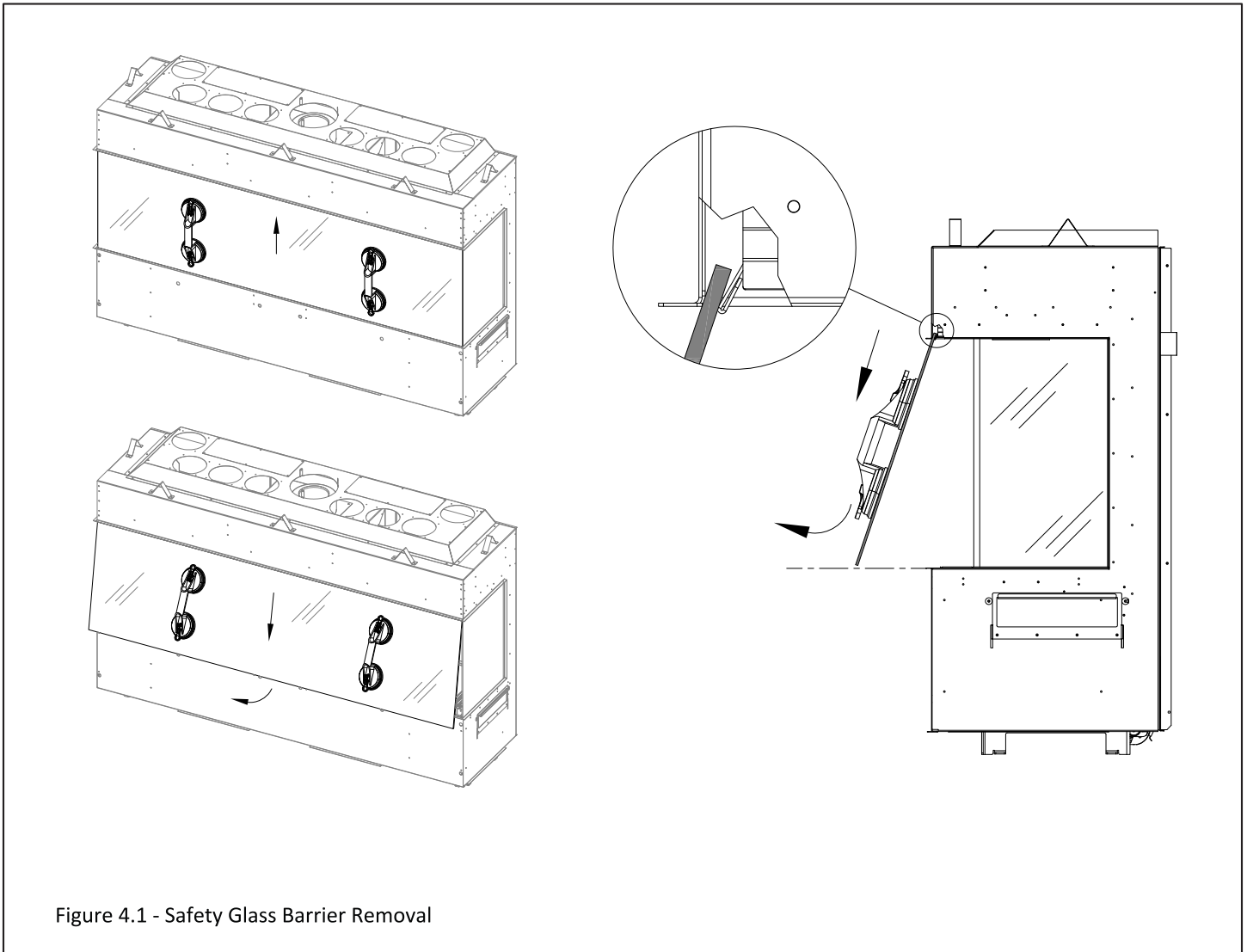

4.1.1 Removing The Safety Glass Assembly (continued)

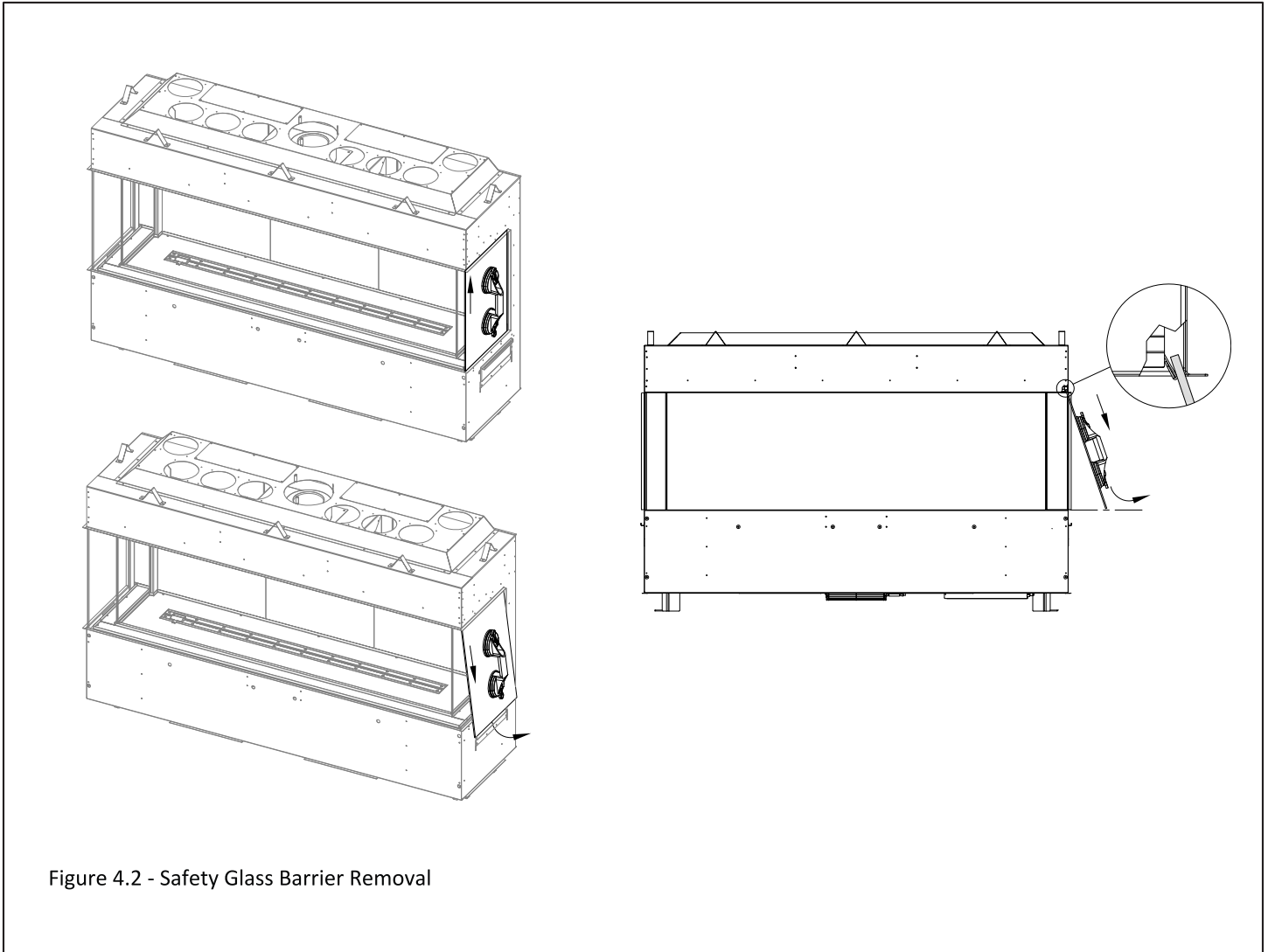

Figure 4.2 - Safety Glass Barrier Removal

4.1.2 Installing The Safety Glass Barrier Assembly

1. Install the side safety glass barrier first. Start with the bottom edge of the glass tilted towards you, slide the top edge of the glass behind the top finishing edge of the fireplace. There is a glass bracket behind this top finishing edge (on the inside of the fireplace) that holds the glass. Ensure the glass is sliding into this bracket. See the image on the right in Figure 4.3 for a close up of this support bracket.
2. When the top edge of the glass is between the bracket and the fireplace outer shell you can tilt in the bottom edge of the glass and position the glass down into its resting position on brackets. Now slide the side safety glass barrier back into the fireplace to leave a gap on the front-side. This will help install the front safety glass barrier.
3. Install the front safety glass barrier pieces following the same procedure as the side glass. Ensure the front glass slides in between the glass bracket and the top edge of the fireplace.

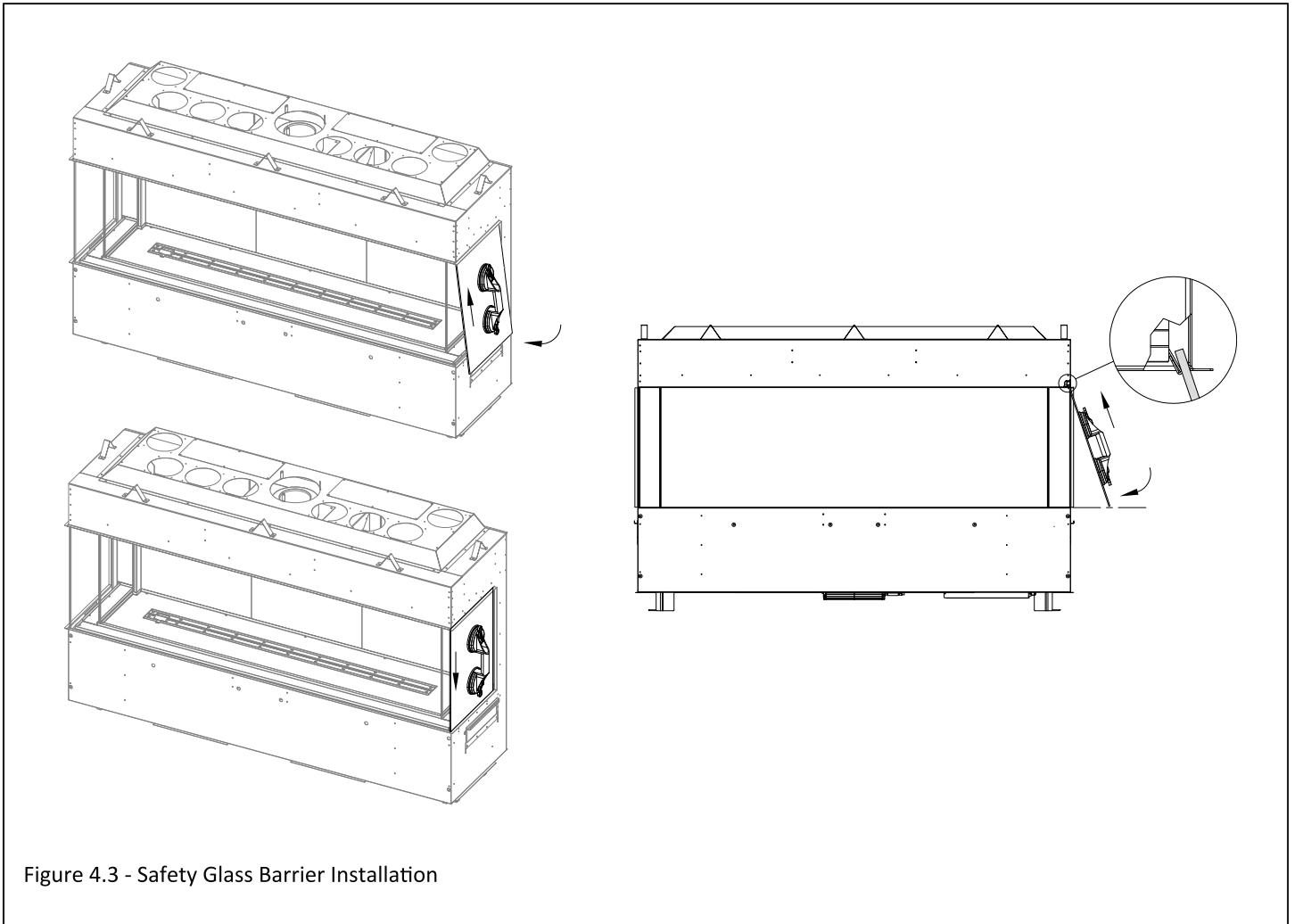

Figure 4.3 - Safety Glass Barrier Installation

4.1.2 Installing The Safety Glass Barrier Assembly (continued)

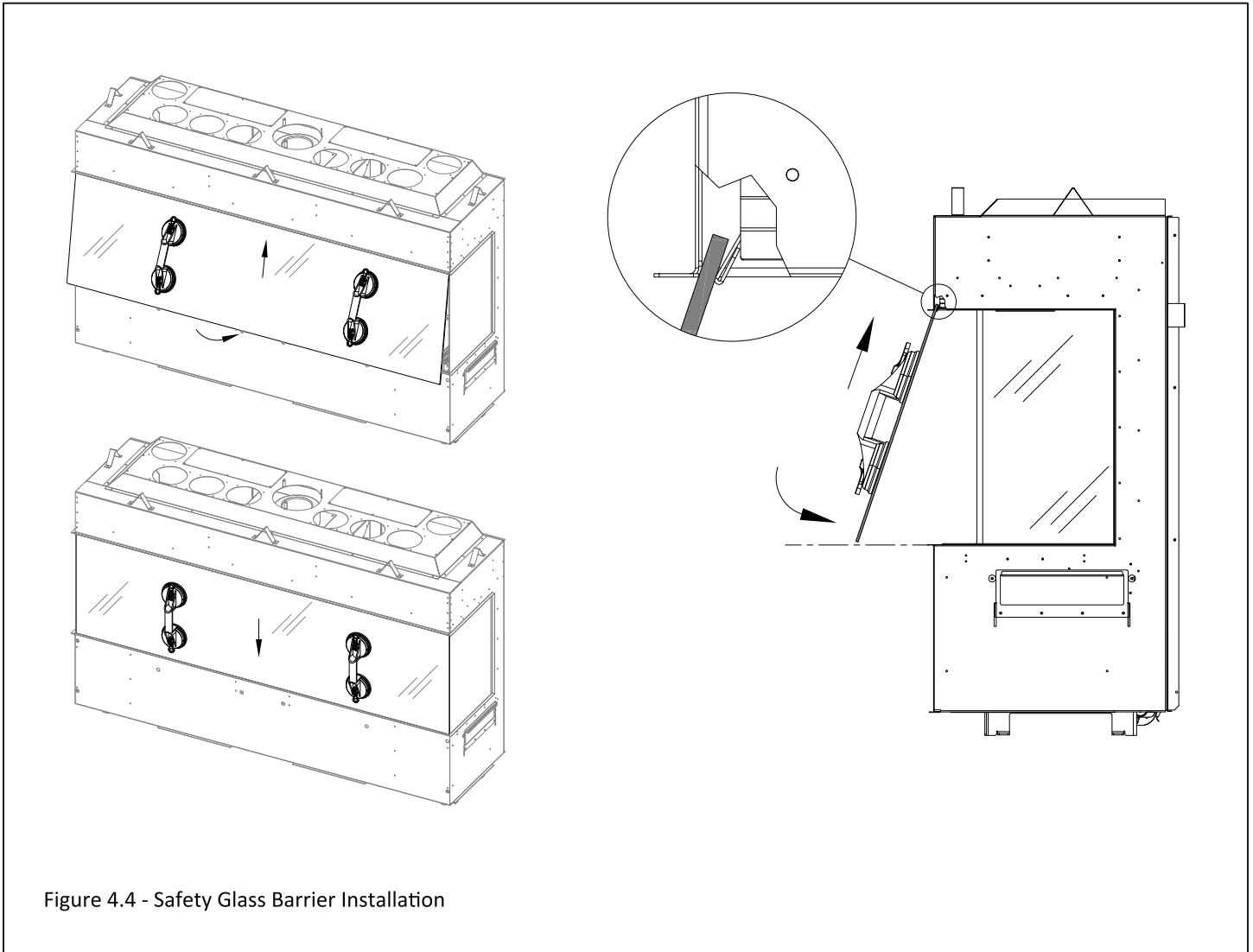

Figure 4.4 - Safety Glass Barrier Installation

4.2 Perimeter Media Tray

You will need to remove the perimeter media tray to access any of the components of the fireplace or to remove the firebox glass.

Removal Instructions:

1. After the safety glass barrier is removed locate the (3) sheet metal screws that secure each side media tray and the front media tray. See Figure 4.5.
2. After removing the sheet metal screws you can lift up and remove the media trays. See Figure 4.5. Install in reverse order.

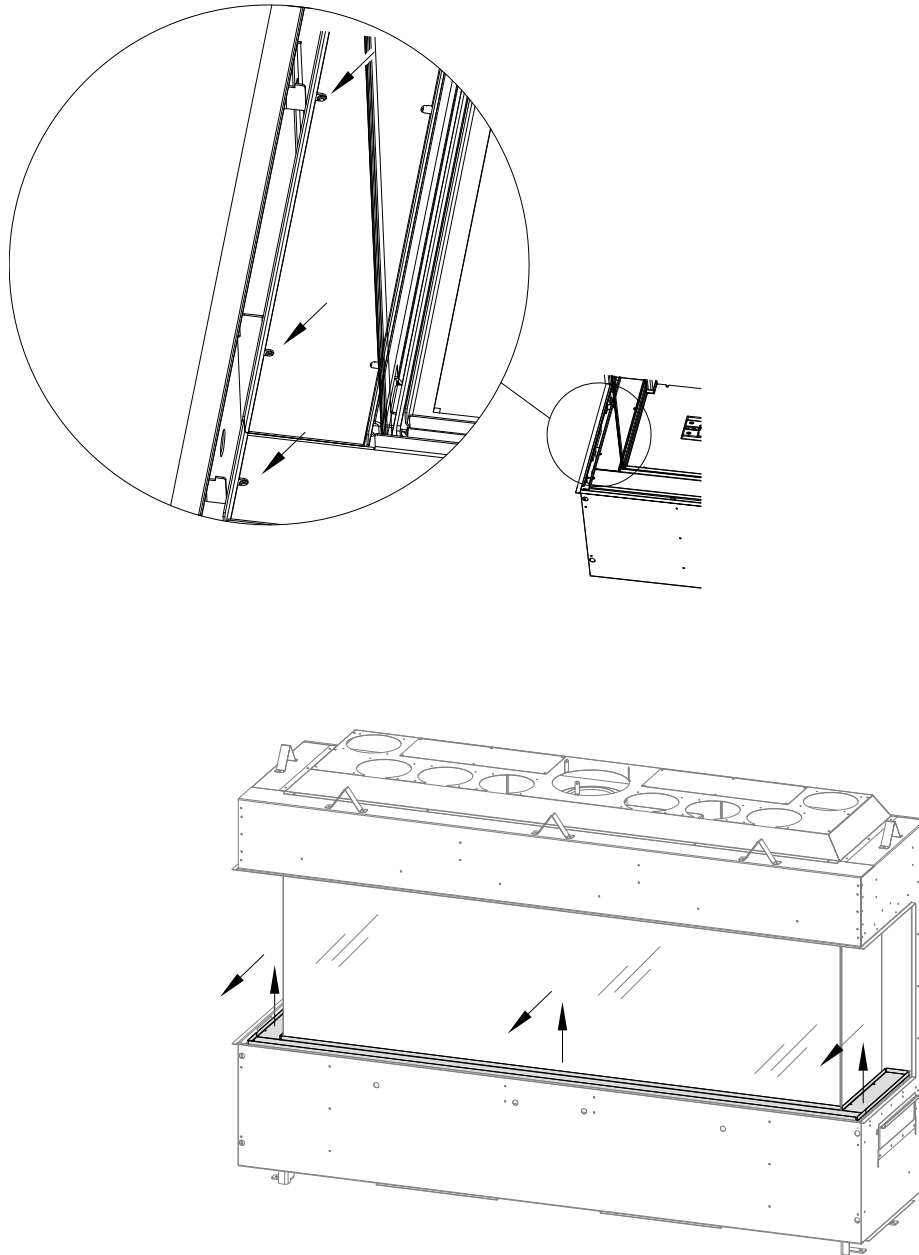

Figure 4.5 - Removing Perimeter Media Tray

4.3 Firebox Glass

WARNING: Do not operate this fireplace with the glass removed, cracked, or broken. Replacement of the glass assembly should be done by a licensed or qualified service person. If a glass assembly becomes damaged, it shall be replaced with the manufacturer's glass assembly for this appliance.

The firebox glass for this fireplace is ceramic glass.

The firebox glass provides a sealed system for the fireplace. This consists of the firebox glass and the silicone corner gasket.

4.3.1 Removing The Firebox Glass

WARNING: Do not remove the glass assembly when hot.

1. Remove the perimeter media tray by lifting it up and out of the slot it is installed. See Figure 4.5.
2. Start with the front glass. Attach suction cups to the front firebox glass.
3. Remove the 7/16" nuts that secure the upper glass bracket and remove this bracket for the front glass as shown in Figure 4.7. Save this bracket to reinstall the glass.
4. Loosen the 7/16" nuts that secure the lower glass brackets as shown in Figure 4.7. You do not need to remove these brackets.
5. Start by lifting the front piece of glass as shown in Figure 4.6 to remove the front firebox glass.

Note: You may need to peel away the small amount of silicone that is at the top and bottom corners of where the front and side pieces of glass meet. The silicone sealing strips should stay attached to the side pieces of glass when removing the front glass pane.

6. Next remove the upper glass brackets and loosen the lower glass brackets for the side firebox glass pieces. For corner installations you will need to remove the glass pane by hand on the side that was not converted to the corner, as a suction cup will not fit on the side. The side of the fireplace that you converted to the corner viewing area will now allow greater access where you can use the suction cup. If you are installing this fireplace as a 3-sided (Bay) installation you will have access to use the suction cups on both firebox side glass panes. To remove the side firebox glass follow the steps outlined above for the front glass removal.

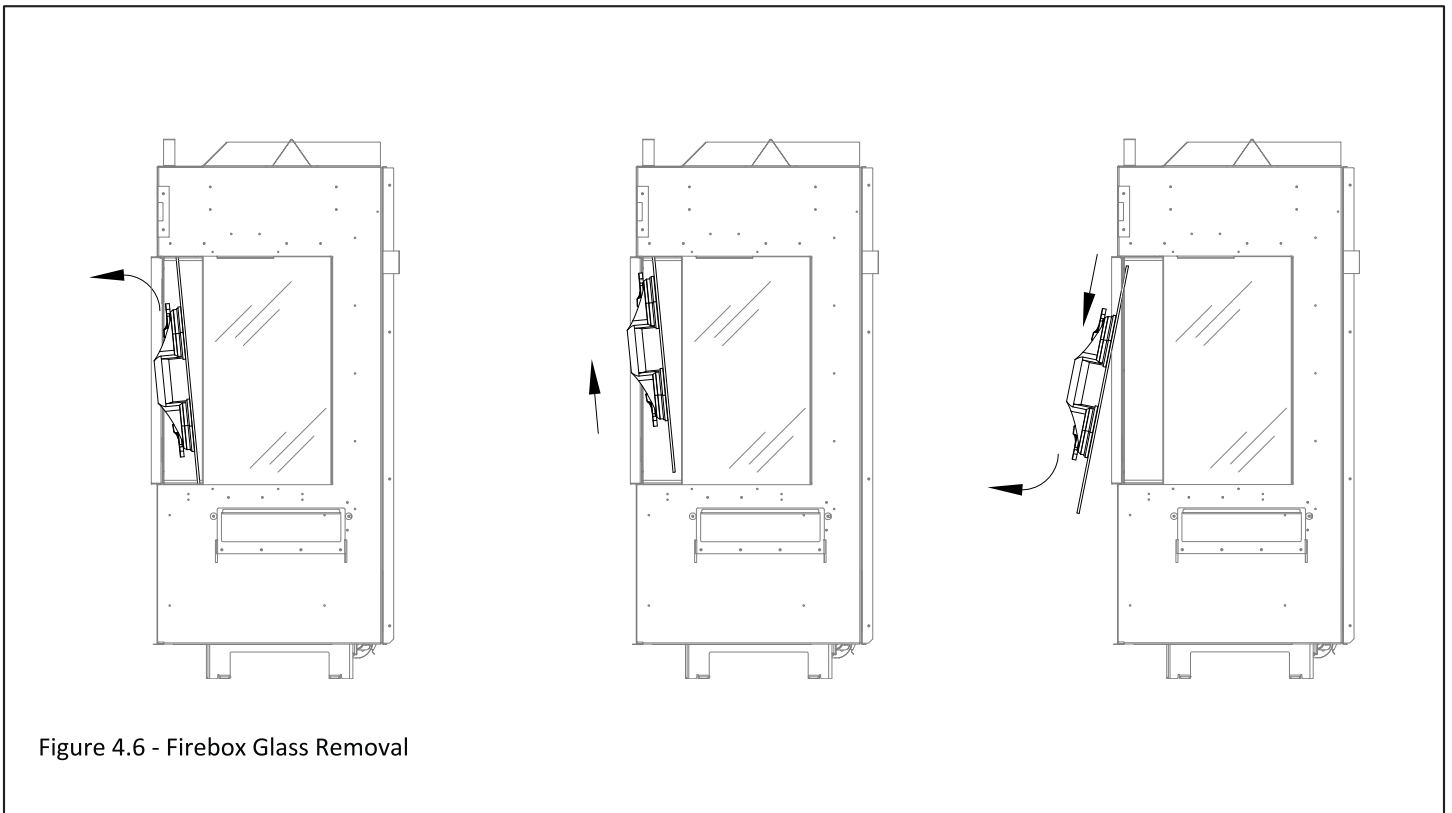

4.3.1 Removing The Firebox Glass (continued)

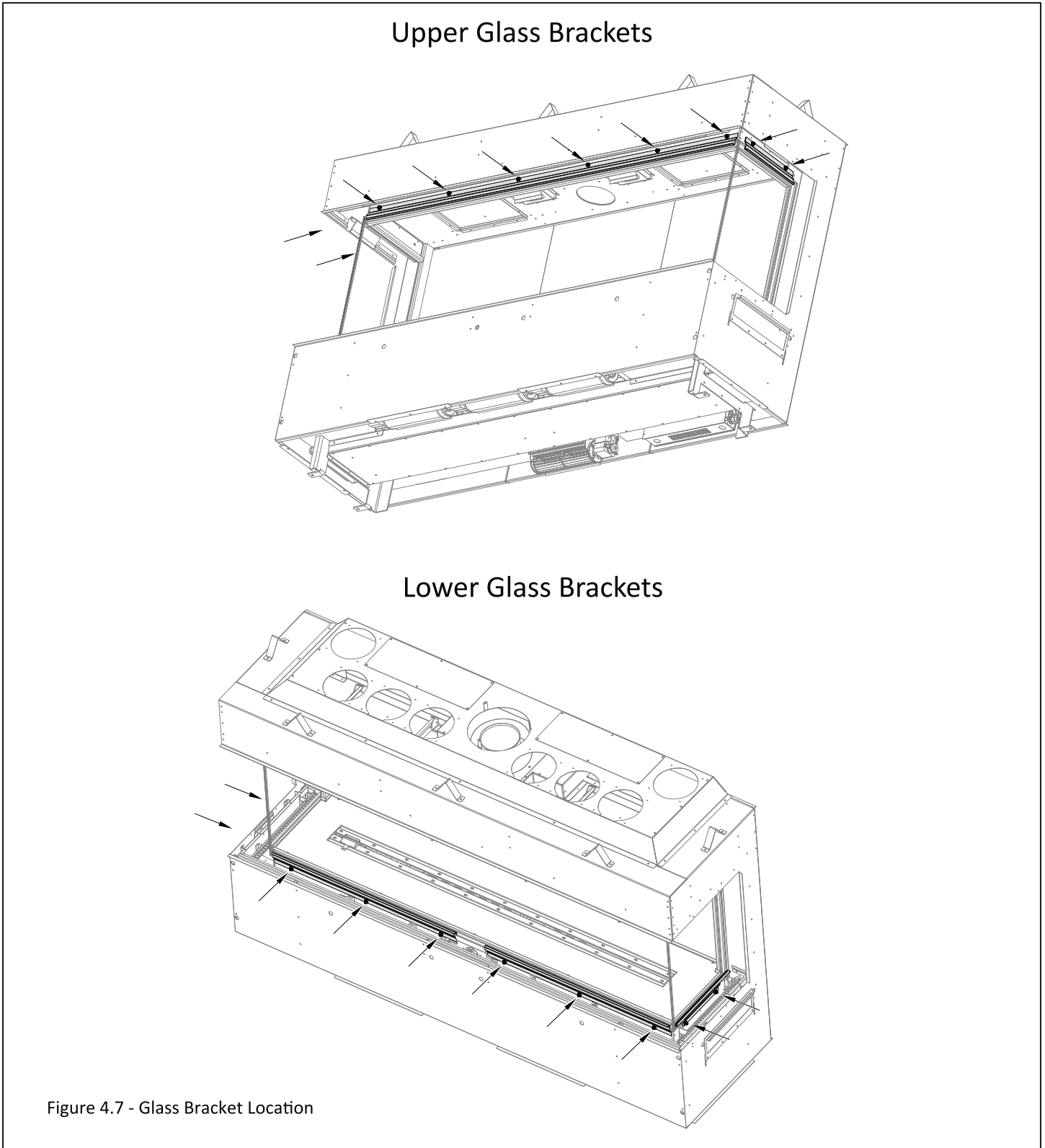

Figure 4.7 - Glass Bracket Location

4.3.2 Installing The Firebox Glass

Note: When installing the firebox glass and tightening the lower glass brackets ensure that no crushed media has fallen down on the brackets. Remove any crushed media before tightening.

1. Start with installing one of the side glass pieces first. Ensure the silicone sealing strips are installed. Have the lower glass brackets already installed with the nuts loose. Install the side firebox glass into place. Install the glass to the firebox by securing the upper glass bracket with the 7/16" nuts. Tighten the lower glass brackets now.

For corner installation you will have to install the side firebox glass pane by hand on the side that still has the block off plate installed. On the side that you converted to the view-able corner you can use the suction cup. On a 3-sided installation you will have access to use the suction cup on both side firebox glass panes.

2. Install the front piece of glass. When installing the front piece of glass you may find it helpful to start with the bottom glass brackets installed but left loose. As you lift the glass into place (See Figure 4.9) start with the glass slightly offset to the side of the firebox that does not have the side glass installed yet. You are able to slide the front glass sideways into the silicone sealing strip of previously installed side firebox glass.

Use your finger to push the silicone strip securely into the edge of the front glass. See Figure 4.8 for a top-down view of how the front glass is sealed inside the silicone channel. Secure the front glass by installing the top glass bracket and secure both the top and bottom brackets.

3. Now you can install the remaining side firebox glass. At the opposite side you can use your finger or a small tool to peel open the edge of the silicone strip as you press the side firebox glass up against the front glass. Ensure the glass is seated into the channel on both sides.
4. Secure the remaining side firebox glass bracket with the 7/16" nuts. Tighten all the 7/16" nuts that secure the upper and lower glass brackets as shown in Figure 4.7.
5. Apply high temperature silicone to the top and bottom corners of where the front and side firebox glass pieces meet. See Figure 4.10.
6. Reinstall the perimeter media tray.

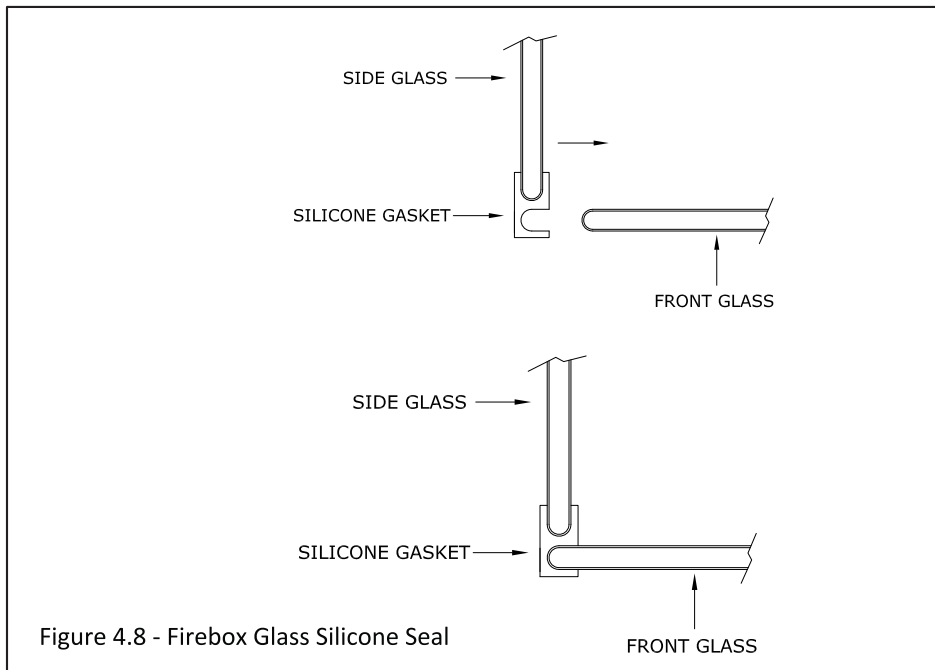

Figure 4.8 - Firebox Glass Silicone Seal

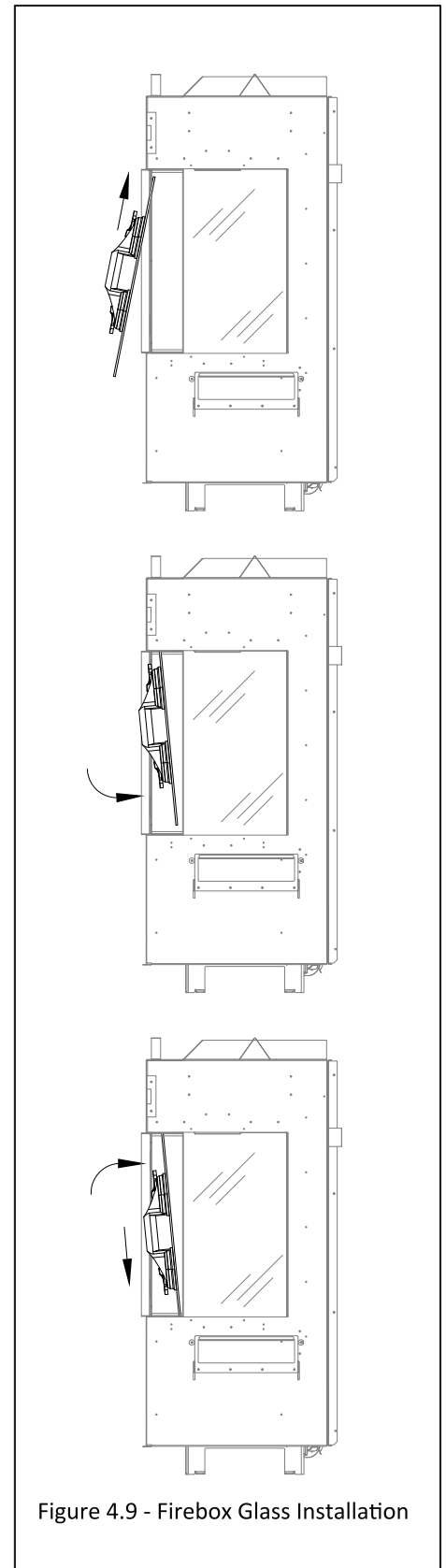

Figure 4.9 - Firebox Glass Installation

4.3.2 Installing The Firebox Glass (continued)

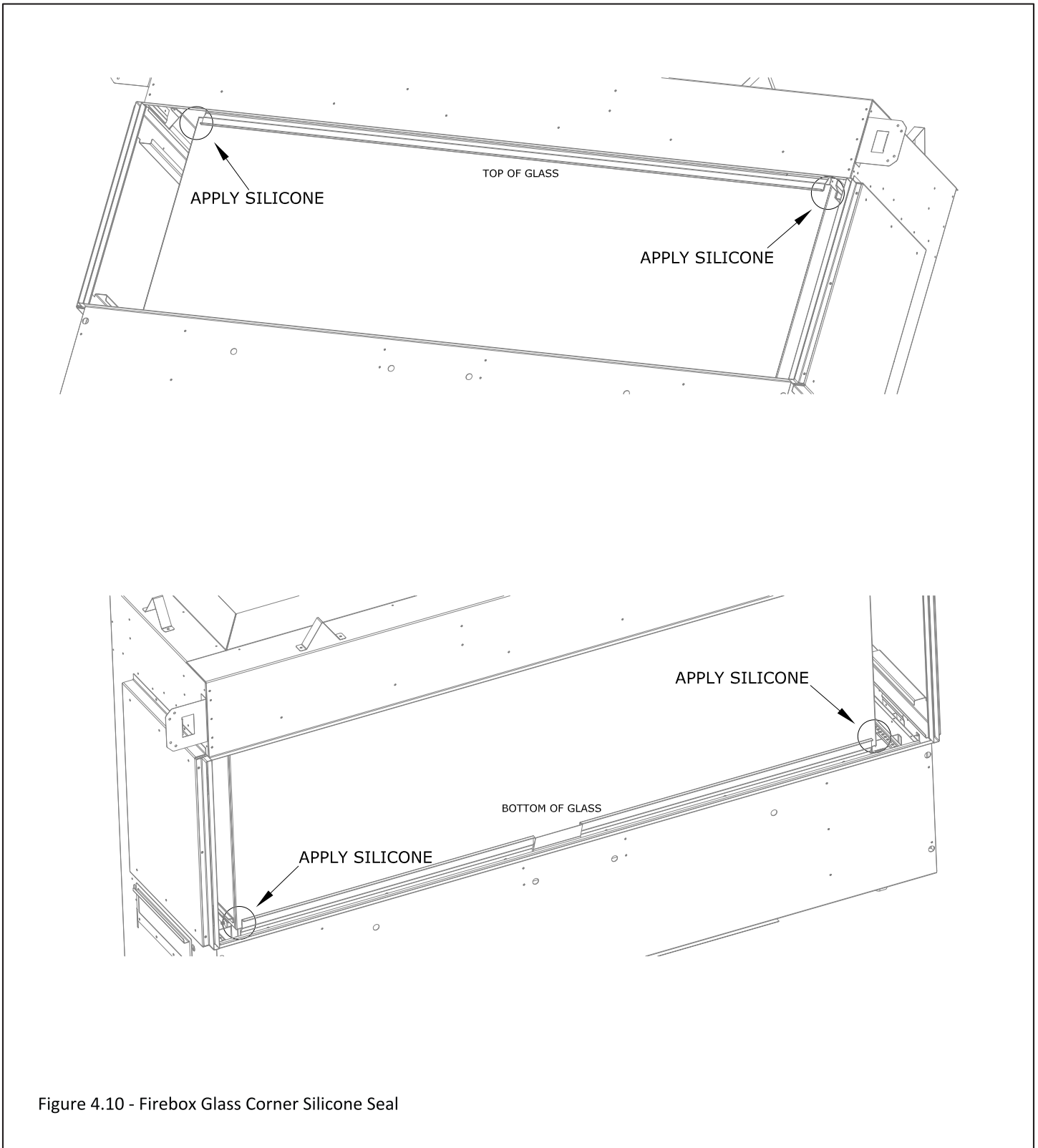

Figure 4.10 - Firebox Glass Corner Silicone Seal

4.4 Black Glass Panel Installation

- If converting to propane, complete the conversion before installing the black glass panel set. Follow the conversion instructions included with the fireplace.
- Follow the steps in reverse for panel removal.
- Note: it will be easier to install the rear perimeter black glass panels in step #3 if you remove the side firebox glass. This will give you greater accessibility to the panel clip location.

Installation

1. Remove the exterior safety glass barrier, perimeter media tray, firebox glass, and crushed glass.
2. Install the (3) rear interior firebox black glass panels. These three panels are the same size and interchangeable. Secure with (2) rear firebox panel clips and (2) sheet metal screws as shown. See Figure 4.11

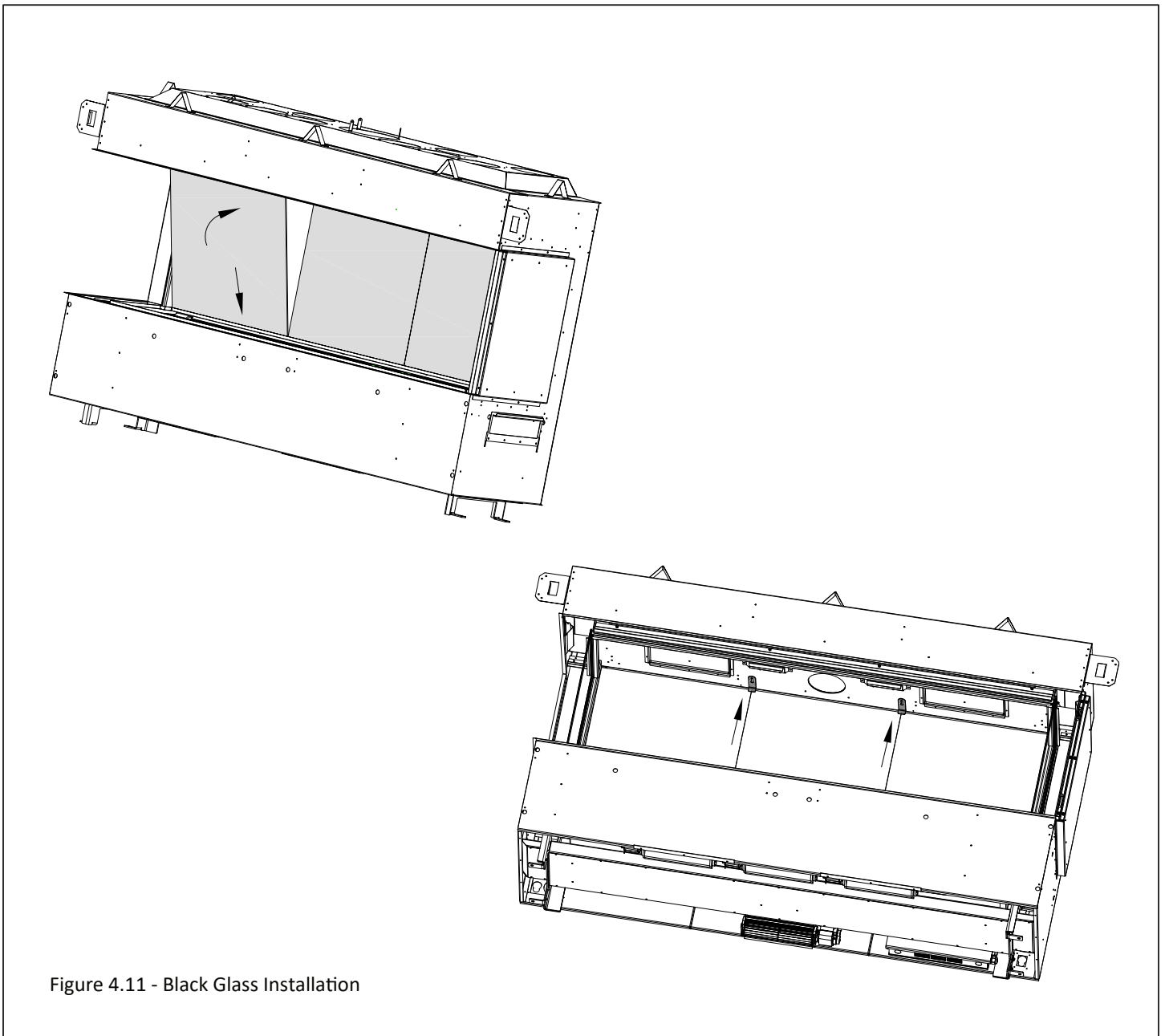

Figure 4.11 - Black Glass Installation

4.4 Black Glass Panel Installation (continued)

3. Install the (2) rear perimeter black glass panels by tilting them sideways until you get them to the back of the fireplace. Place the top edge of the glass up into the preinstalled top perimeter panel clip and tilt into place. While holding the black glass in place, use the supplied perimeter panel clip and secure the clip on the bottom of the black glass with (2) sheet metal screws. See Figure 4.12.
4. Corner Installation only - Install one side black glass panel by sliding them into position as shown in Figure 4.12.

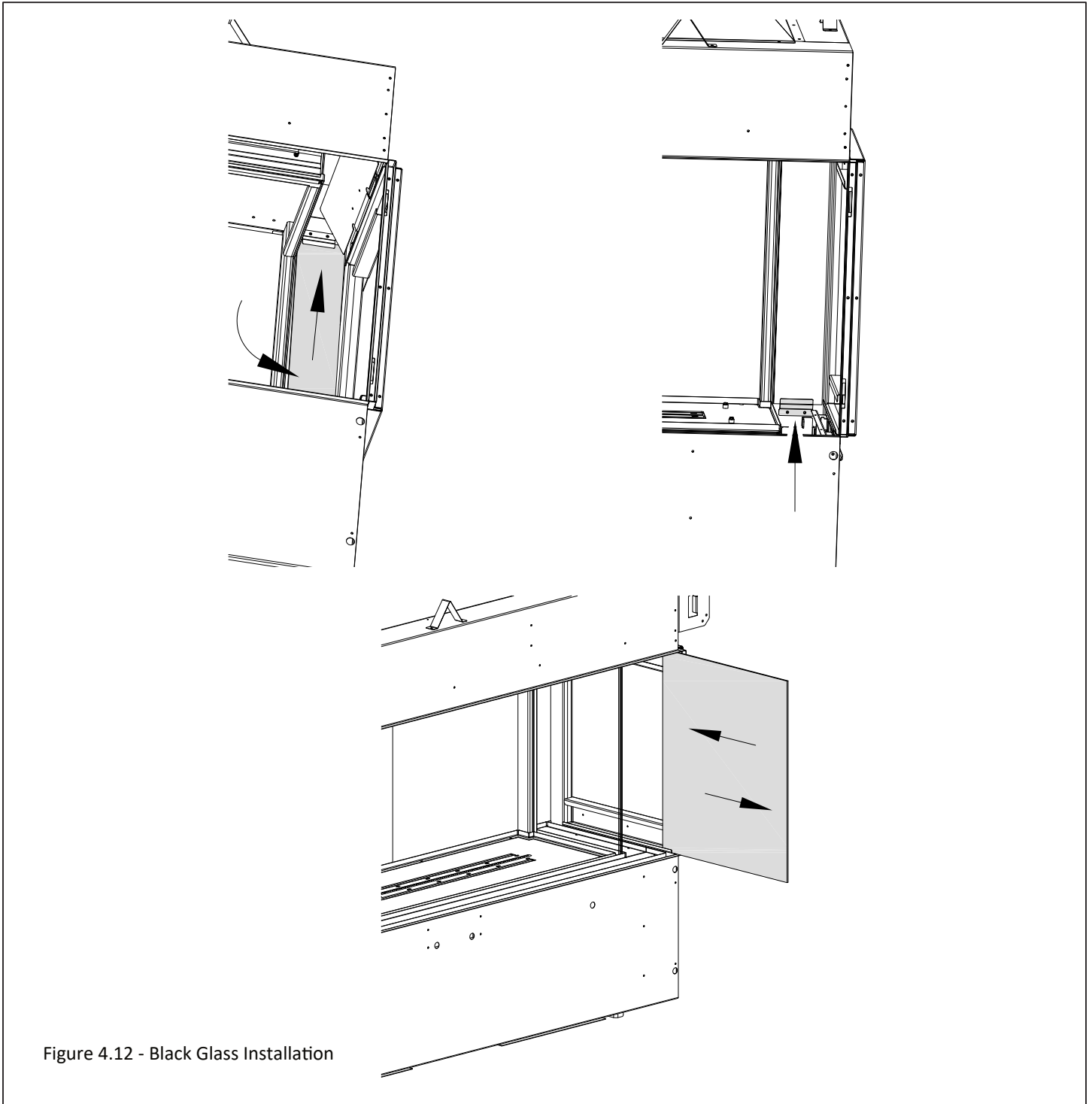

Figure 4.12 - Black Glass Installation

4.5 Control Board Removal and Installation

WARNING: If burner and/or pilot have been burning, use appropriate protection to avoid burns or damage to personal property before removing any components.

DO NOT OPERATE THIS APPLIANCE WITHOUT THE SEALING GASKET (LOCATED UNDER THE CONTROL BOARD) IN PLACE. IF GASKETING IS DAMAGED, IT MUST BE REPLACED.

CAUTION: Check all connections for leaks with soapy water, whether field or factory made.

4.5.1 Control Board Removal

1. First locate the main shut-off valve upstream of the appliance connector and close the valve (Figure 4.13). Then disconnect the electrical power of the fireplace.
2. Remove the safety glass barrier, perimeter media tray, firebox glass, and crushed media. You may find it beneficial to remove the lower glass brackets for increased accessibility. Figure 4.14, 4.15, and 4.16.
3. Disconnect the wiring lead from the safety system to the on/off switch wiring.
4. Remove the (2) sheet metal screws that secure the switch panel. Lift this panel off its support bracket and locate the slits in the control module brackets. Slide the switch panel into these openings to secure it during control board removal. Figure 4.17 and 4.18.
5. Remove all the sheet metal screws around the perimeter of the burner media tray and all sheet metal screws along the center of the burner. Remove the burner media tray and burner tube. Figure 4.19.
6. Remove the (24) sheet metal screws securing the control board to the bottom of the firebox. Figure 4.20.
7. Start by pulling up and out the control board. As you lift the board up you will have to tilt the control board towards you so the valve and module pivot into the opening. Lift the control board up to gain access to under the control board. Figure 4.20.
8. Make sure gas supply is turned off. Lean over the tilted control board and disconnect the gas line flex tube. This gas line flex tube goes from the fireplace gas valve to the supply gas line entering the fireplace.
9. Disconnect both top light kit leads from the wire harness on the IFC control module.
10. Remove the control board.

4.5.2 Control Board Installation

- Install the control board and all previously removed components in reverse order.
- When installing the control board make sure you are aligning the holes in the control board with the holes in the firebox bottom. **VERIFY SEALING GASKET IS IN PLACE.**

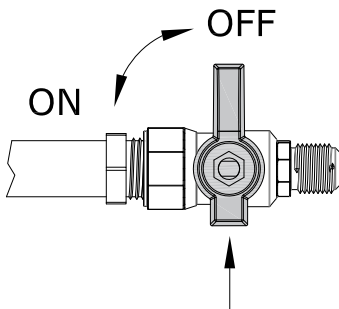

Figure 4.13 - Turn Off Gas

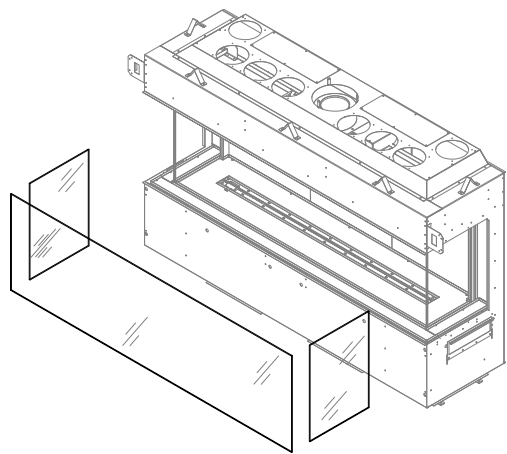

Figure 4.14 - Remove Safety Glass Barrier

4.5 Control Board Removal and Installation (continued)

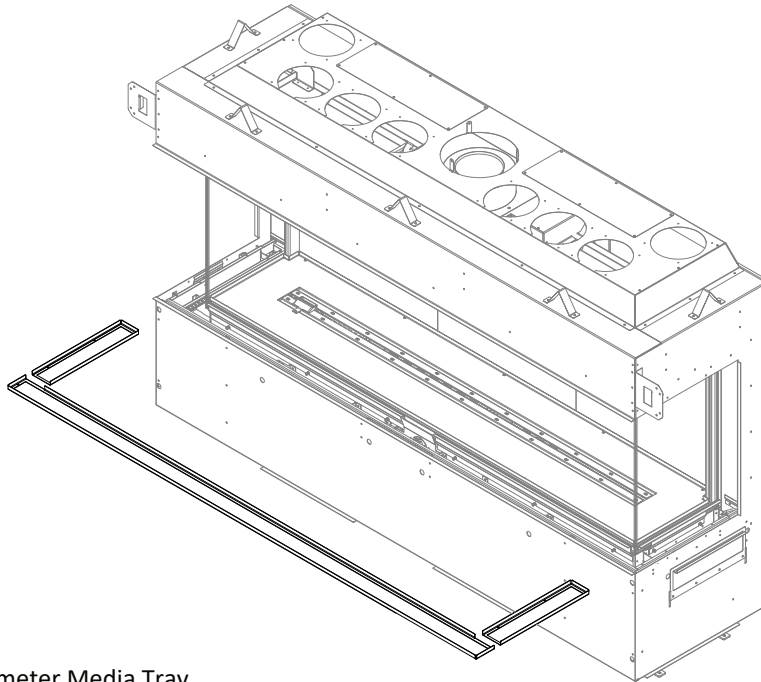

Figure 4.15 - Remove Perimeter Media Tray

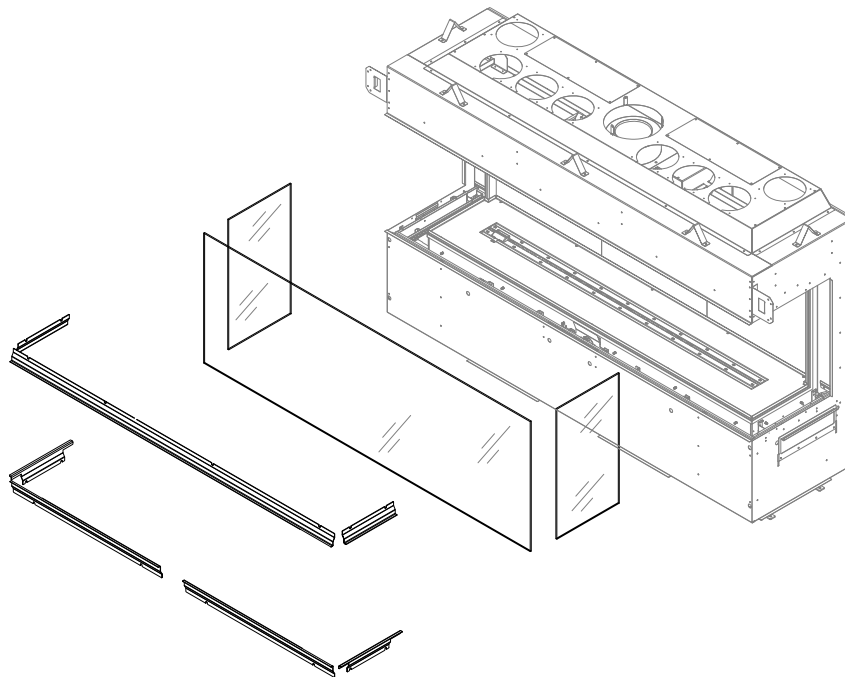

Figure 4.16 - Remove Firebox Glass

4.5 Control Board Removal and Installation (continued)

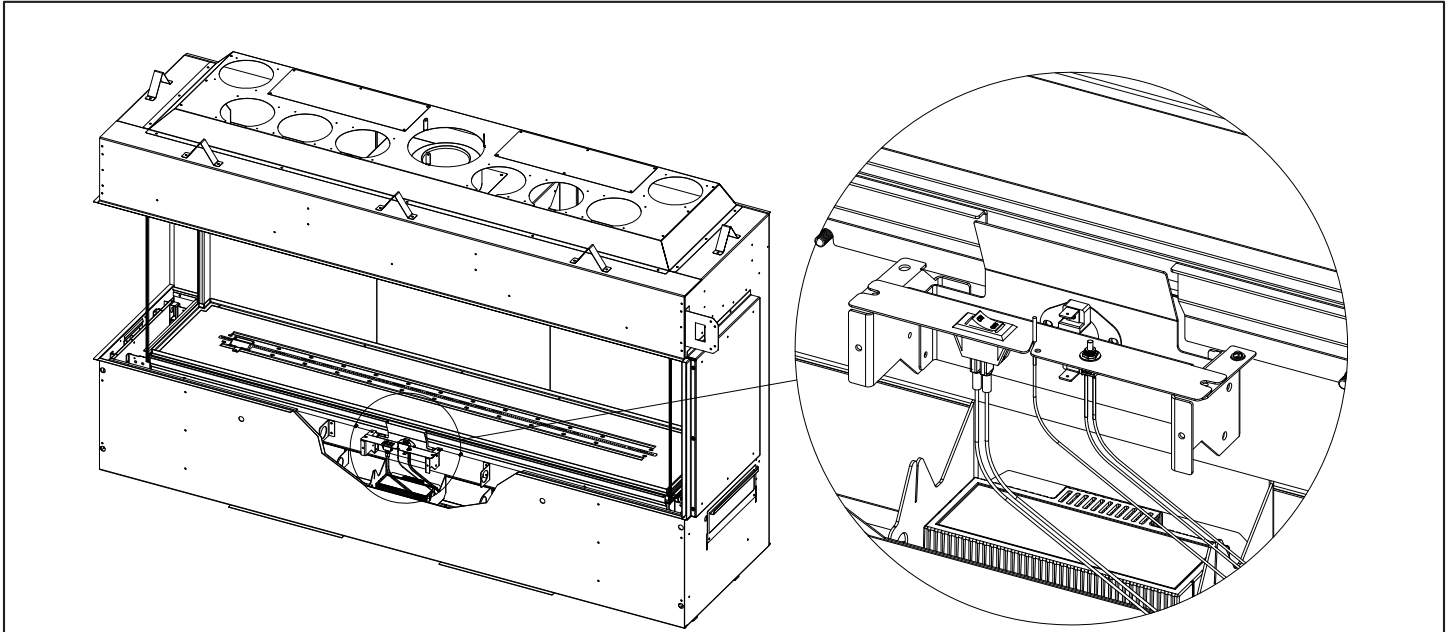

Figure 4.17 - Switch Panel

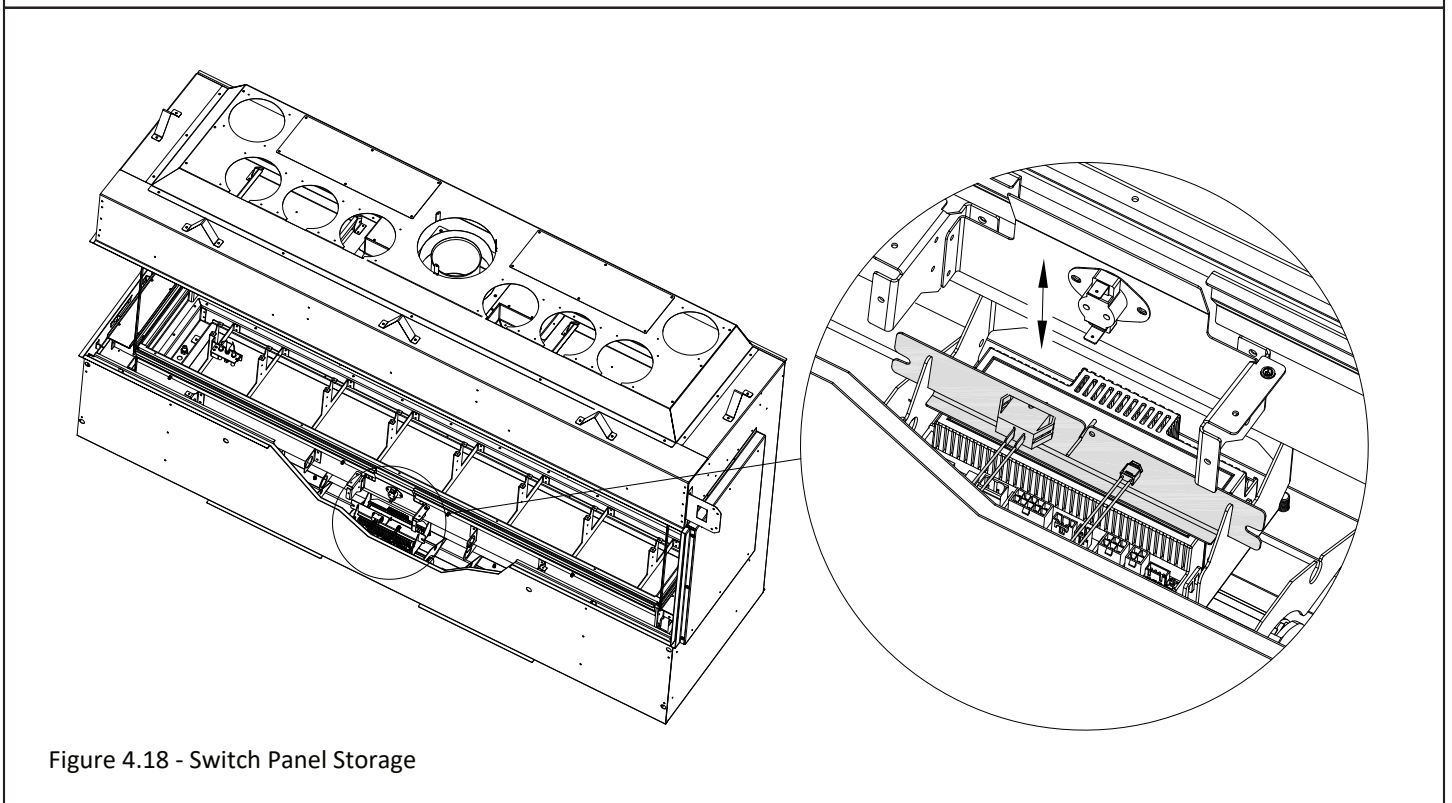

Figure 4.18 - Switch Panel Storage

4.5 Control Board Removal and Installation (continued)

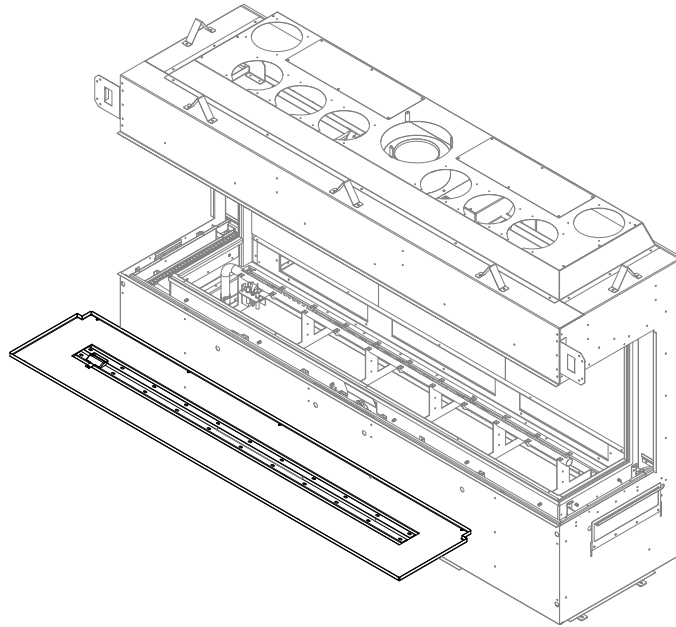

Figure 4.19 - Burner Media Tray and Burner Tube Removal

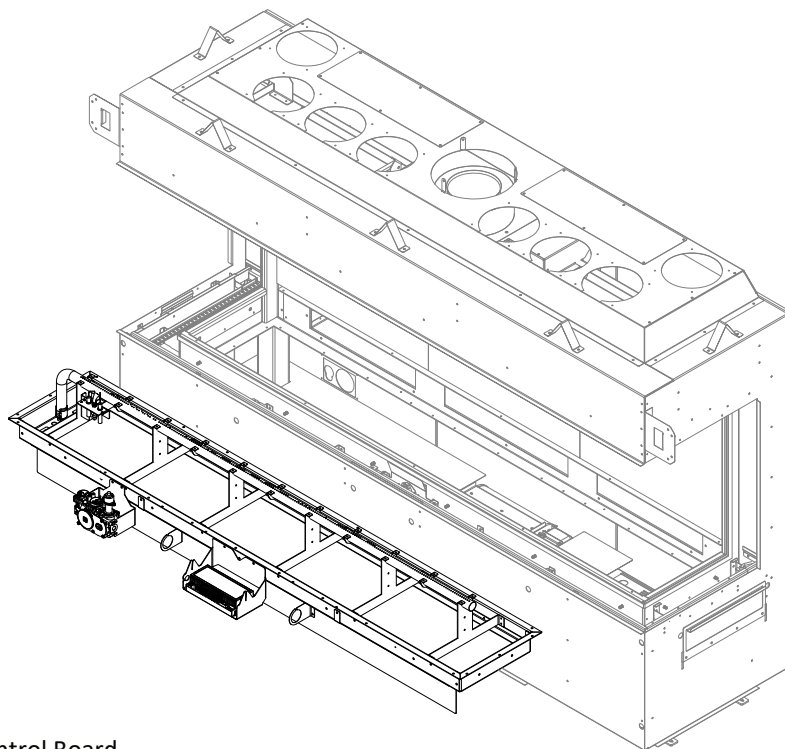

Figure 4.20 - Remove Control Board

5.0 Replacement Parts List



HUSSONG MANUFACTURING CO., INC.
P.O. Box 557, 204 Industrial Park Road
Lakefield, Minnesota USA 56150-0577

Replacement parts are available through your local dealer.
Contact your local dealer for availability and pricing.
The following warning is for replacement parts for this
appliance.

⚠ WARNING: This product can expose you to chemicals including Lead, which is [are] known to the State of California to cause cancer, birth defects or other reproductive harm. For more information, visit www.P65Warnings.ca.gov.

Control Board and Parts				
S.I.T. Complete Board Assembly - Natural Gas	G7220-150		Remote Learn Button	700-422
S.I.T. Complete Board Assembly - Propane	G7220-151		Remote Antenna Extension	700-ANT
S.I.T. IPI Gas Valve - Natural Gas	700-567		IPI Pilot Assembly - Natural Gas	900-064A
S.I.T. IPI Gas Valve - Propane	700-567-1		IPI Pilot Assembly - Propane	900-064-1
Main Power Wire Harness	700-350A		Pilot Orifice - Natural Gas - #.023NG	700-123
Proflame 2 IFC Module	700-652-7		Pilot Orifice - Propane - #.014LP	700-114
SIT Wire Harness Assembly	700-653		PSE Conversion Kit - Natural Gas	NCK-G7220-P50
Fan / Light Kit Wire Harness	700-657		PSE Conversion Kit - Propane	LCK-G7220-P50
ON/OFF Wire Harness	700-656		Natural Gas - Valve Stepper Motor	700-504
Ember Bed AUX Harness	800-AUX		Propane - Valve Stepper Motor	700-504-1
36" Black x 3/8" Gas Line (into valve)	700-383B		Burner Orifice - #23 - Natural Gas	700-2223
32" Flare x Brazed Fitting	700-232F		Burner Orifice - #2.20MM - Propane	700-220M
S.I.T. Transmitter (Remote Control)	700-408		Burner Tube	G7220-350

Glass and Glass Parts	
Firebox Glass - Front	G7220-FGF
Firebox Glass - Side	G7220-FGS
Safety Glass - Front	G7220-SGF
Safety Glass - Side	G7220-SGS
Firebox Glass Gasket (attaches to firebox) - 30'	500-426
Front Firebox Glass Brackets	G7220-FFB
Side Firebox Glass Brackets	G7220-SSB
Firebox Silicone Strips - Clear (seals side and front firebox glass panes)	700-20C
Firebox Silicone Strips - Black (seals side and front firebox glass panes)	700-20B

Fan System	
Fan (fireplace uses 4 of these)	600-093
Fan Wire Harness	600-093WH
Thermal Switch - Fan System	700-TSF

Safety System	
Fan Safety Kit (Includes module and wire harnesses)	GEN-FSK
Safety Control Module	700-SCM
Thermal Sensor Wire	700-TSW
Fan Current Coil	700-FCC
Safety Power Harness	700-SPH
Safety On/Off Toggle Wire Harness	700-STH
Safety LED Wire	700-SLW

Top Light Kit	
20W Halogen Bulb	600-676
Light Kit - Top	600-TLK
Bottom LED Light Kit	
Firebox 59" LED Assembly	LED59
Exterior 98" LED Assembly	LED98
LED Controller (V5-LWT)	LED-DRV
Power Supply (shared with safety system)	LED-POW2
3-Wire Adapter (LED Controller)	LED-WHA
LED Remote	LED-RT4

Log Set Replacement Parts		
	Weathered Log Set	Birch Log Set
11 Piece Log Set	GENL-500	GENL-B501
Log #1	GENL-1	GENL-B1
Log #2	GENL-2	GENL-B2
Log #3	GENL-3	GENL-B3
Log #4	GENL-4	GENL-B4
Log #5	GENL-5	GENL-B5
Log #6	GENL-6	GENL-B6
Log #7	GENL-7	GENL-B7
Log #8	GENL-8	GENL-B8
Log #9	GENL-9	GENL-B9
Log #10	GENL-10	GENL-B10
Log #11	GENL-11	GENL-B11

Additional Components	
3/4" Ice Crushed Glass - 35 lbs.	435-ICE
5" (127mm) Restrictor Plate	900-086
Manual 3/8" Gas Shut-off Valve	700-380

Corner Conversion Kit*	
Glass Corner Conversion Kit	GENL-CCK
*Order one kit for left or right corner installation and order two kits for 3-sided "Bay" Installation	

